

coffers and troughs

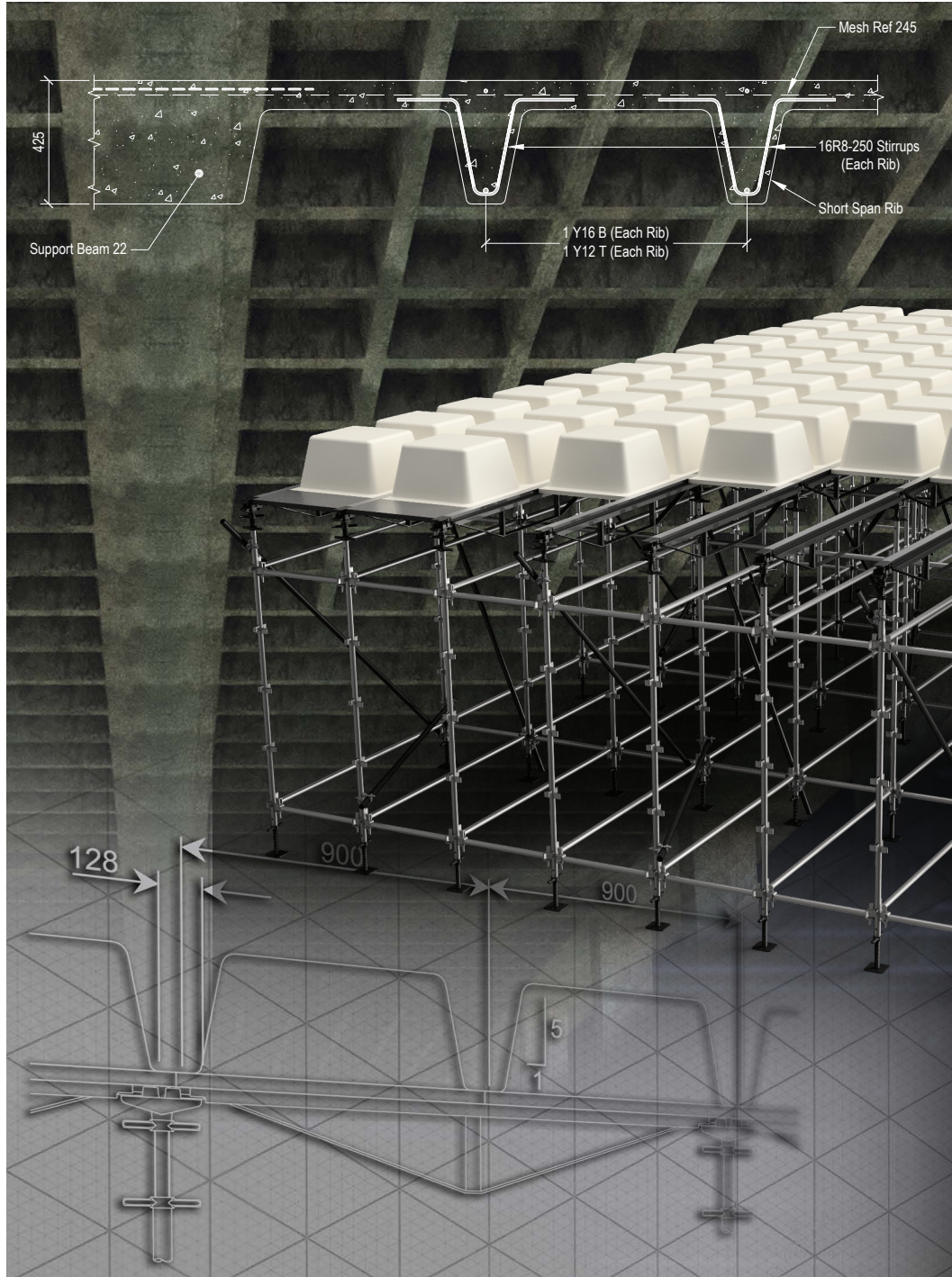

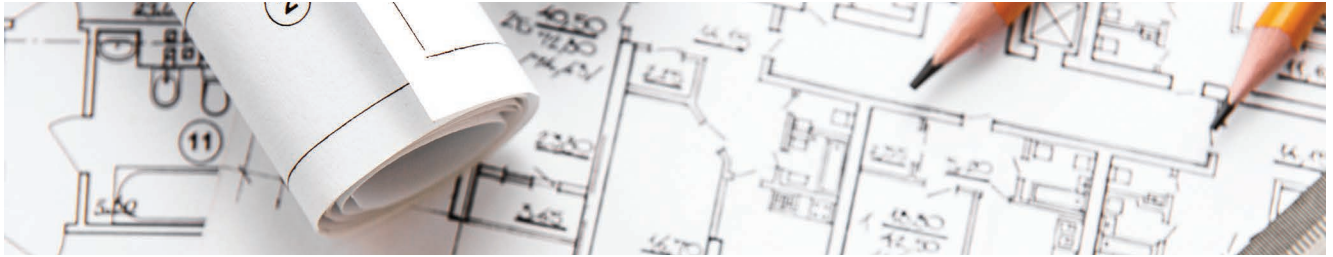

Waco Engineering Services (WES) is a wholly owned subsidiary of Waco Africa Pty Ltd, a leading industrial services company offering a diverse range of services. As a Temporary Works consulting business WES offers a full “risk ringfenced” service to customers by covering the design and the on-site approval of temporary works.

WES works closely with its sister companies which include Form-Scaff, the market leading formwork and scaffolding company and the exclusive distribution partner for Doka in Sub-Saharan Africa. Form-Scaff’s tried and tested Coffers and Trough systems are unique, delivering two way and one way concrete slab spanning solutions.

By partnering with Form-Scaff, Waco Engineering Services can limit your risk exposure related to the equipment, design and erection of temporary works. The benefits include:

1 REDUCED RISK

The WES team of professionally registered engineers have collectively over 100 years of temporary works and construction experience, making for safe, efficient and practical solutions.

2 A ONE-STOP SERVICE

Working with Form-Scaff, WES is able to offer the full range of services required for temporary works including design, supply of equipment, erection and inspection.

3 REDUCED COSTS

By getting WES involved from the start to advise and design options, you can ensure that you achieve the most cost-effective temporary works solution.

Through WES and Form-Scaff you can reduce your risk and ensure you are compliant with the South African Construction Regulation. WES is a Level 2 BBBEE contributor and has its own Professional Indemnity cover, over and above the Waco Group’s comprehensive cover.

WACO
africa



abacus
SPACE SOLUTIONS

form-scaff
Formwork & Scaffolding Solutions

Sanitech

SGB-CAPE

SkyJacks

WES
Waco Engineering Services

Disclaimer

- Copyright in this Concrete Design Guide vests in Waco Engineering Services (“WES”), a subsidiary of Waco Africa (Proprietary) Limited and extends inter alia, to the making of copies in whole or in part without the prior written consent of WES.
- While every effort has been made to ensure the accuracy of the information in this Concrete Design Guide, neither WES or Mitchell & Associates accept any responsibility for any errors which may occur as a result of the misappropriation or misinterpretation of the contents of this Concrete Design Guide and are not liable for any loss of any nature whatsoever that may be incurred as a result of such misappropriation or misinterpretation.

Page 02 ■ General Information

Page 03 ■ Architectural considerations and advantages

Page 04 ■ Structural considerations and advantages

Page 05 ■ Coffer slab design:

Page 06 ■ Design procedure

Page 10 ■ PART 1 - Coffer beam identification (Steps 1 to 12)

Page 15 ■ PART 2 - Coffer support beam design (Steps 13 to 30)

Page 35 ■ PART 3 - Coffer slab design - ribs and structural topping (Steps 31 to 50)

Page 55 ■ Trough slab design:

Page 56 ■ Design procedure

Page 61 ■ PART 1 - Trough and beam identification (Steps 1 to 12)

Page 68 ■ PART 2 - Trough support beam design (Steps 13 to 30)

Page 86 ■ PART 3 - Trough slab design - ribs and structural topping (Steps 31 to 50)

Page 104 ■ Summary

Page 105 ■ Reference Tables

Page 106 ■ Abbreviations and conversions

Page 109 ■ Branch Contact Details

■ The information given in this Concrete Design Guide regarding the design or the method of designing the reinforced concrete elements, may change without prior notice.

GENERAL INFORMATION

Overview

This Concrete Design Guide provides guidance for the reinforced concrete design of Coffer and Trough slabs and only deals with the Coffer and Trough sizes given in Table 1.

Pre-tensioning and post-tensioning options, in lieu of, or in combination with reinforcing steel, are excluded from this Concrete Design Guide.

Design and drawings

Waco Engineering Services (WES) offers the service of producing concrete and reinforced concrete drawings complete with bending schedules for Coffer and Trough slabs in accordance with the designer's specifications.

If the concrete drawings are not prepared by WES, it is recommended that the completed concrete drawings are submitted to WES, in CAD format, in order for WES to check and offer adjustments for consideration to ensure optimum use of the Coffers, Troughs and support work.

The drawings and details shown in this Concrete Design Guide are to be used as a guide only and are not to be used as final working drawings.

Coffer and Trough Equipment:

This Concrete Design Guide is based on equipment that is supplied by Form-Scaff.

Refer to the Form-Scaff Technical User Guide for technical information regarding the various components that make up the Coffer and Trough systems.

Contact Form-Scaff directly to confirm the availability of Coffer and Trough equipment.

Standards and compliance documentation

The reinforced concrete design for Coffer and Trough slabs should be done in accordance with at least:

National Building Regulations (NBR) and Building Standards Act No. 103 of 1977 (amended 2008)

The NBR forms the basis of how buildings in South Africa should be constructed and developed to suit human habitation and provides the law relating to the erection of buildings in the areas of jurisdiction of local authorities.

SANS 10400 The application of the National Building Regulations

This standard covers provisions for building site operations and building design and construction that are deemed to satisfy the provisions of the NBR.

SANS 0100-1 The structural use of concrete - Design

This standard establishes principles for the structural use of concrete including the method of design, material and types of structures.

SANS 10100-2 The structural use of concrete - Materials and execution of work

This standard establishes materials for concrete, proportioning, durability, reinforcing steel, formwork, placing and protection of concrete.

SANS 920 Steel bars for concrete reinforcement

This standard covers the physical and mechanical requirements for carbon steel bars intended for use as reinforcement for concrete.

SANS 282 Bending dimensions and scheduling of steel reinforcement for concrete

This standard covers the bending dimensions, bar schedules and routine inspection of steel bars intended for use as reinforcement for concrete.

SANS 10160-1 Basis of structural design

This standard covers the general structural design procedures and the minimum design loads to be adopted in the design of buildings or their structural members.

SANS 10160-2 Self weight and imposed loads

This standard covers the design guidance and actions for the structural design of buildings and includes densities of materials, self weight of construction works and imposed loads for buildings.

SANS 10144 Detailing of steel reinforcement for concrete

This standard covers all types of reinforced concrete and presents time saving methods of detailing.

Note:

In addition to the SANS 10144, clauses 4.5.6 and 4.11.3 of the SANS 0100-1 must be taken into consideration when specifying the detailing requirements for the reinforcing drawings.

Other Compliance Documentation

- Occupational Health and Safety Act 1993.
- Construction Regulations, 2014.
- ISO 9001.
- OHSAS 18001.
- Municipal bylaws.
- Coffer and Trough Technical User Guide.
- International documentation – when Coffer and Trough systems are used outside of South Africa, the relevant international documentation must be considered/adopted.
- Any other normative references in the abovementioned SANS standards or other specifications or references not given in this Concrete Design Guide.

ARCHITECTURAL CONSIDERATIONS AND ADVANTAGES

Architectural considerations and advantages

- One of the biggest advantages of using Coffer and Trough slabs is the reduction in the required amount of concrete and reinforcing steel, making the structure lighter and more cost effective.
- The use of Coffers and Troughs provides an overall deeper slab which eliminates the need for down-stand beams. This results in an overall reduction in height of the structure and may improve zoning requirements where height limitations are enforced.
- In addition, the elimination of down-stand beams allows an uninhibited layout of services such as pipes and air conditioning ducts which are secured to the soffit of the slab.
- Depending on the configuration and spacing of the columns/supporting structure, the thickness of each Coffer and Trough slab will vary to suit the structural engineer's design requirements.
- In addition to the structural concrete slab thickness, a non-structural screed is usually applied to the top surface of the slab.
- The screed:
 - Varies in thickness at the discretion of the structural engineer (usually between 20 mm and 75 mm thick).
 - Affects the floor to ceiling height.
 - May also be used to slope the top surface of the slab for drainage purposes.
 - May have different surface finishes such as troweled, broomed, exposed aggregate or, with the addition of pigments, provide a colourful aspect.
- The standard sizes of the Coffers and Troughs provides a modular flexibility of column spacing which is particularly important in multi-storey carparks where a less restricted movement of vehicles is required.
- The "waffled" soffit finish of voided slabs is aesthetically pleasing and may be used for the design of ceilings, particularly in commercial projects.
- The use of a "waffled" soffit finish also provides an acoustically advantageous solution for the dampening of sound.

Coffer and Trough illustrations

The in-situ concrete slabs are constructed with voids in the soffit to form a series of ribs.

The beams at the edges of the concrete slab and the beams that span between the columns, are usually the same depth as the ribs.

Coffers are used to form ribs in two directions and Troughs are used to form ribs in one direction.

The Cofferred portion of a slab may be supported on beams between the columns on all 4 sides, or on column heads with beams only at the perimeter of the slab.

The Troughed portion of a slab is surrounded by beams at all 4 sides.

If required, beams may be added between the Cofferred or Troughed portion of the slabs to support additional loads (such as from load bearing walls on the slabs).

The illustrations below shows some examples of different Coffer and Trough slab options.

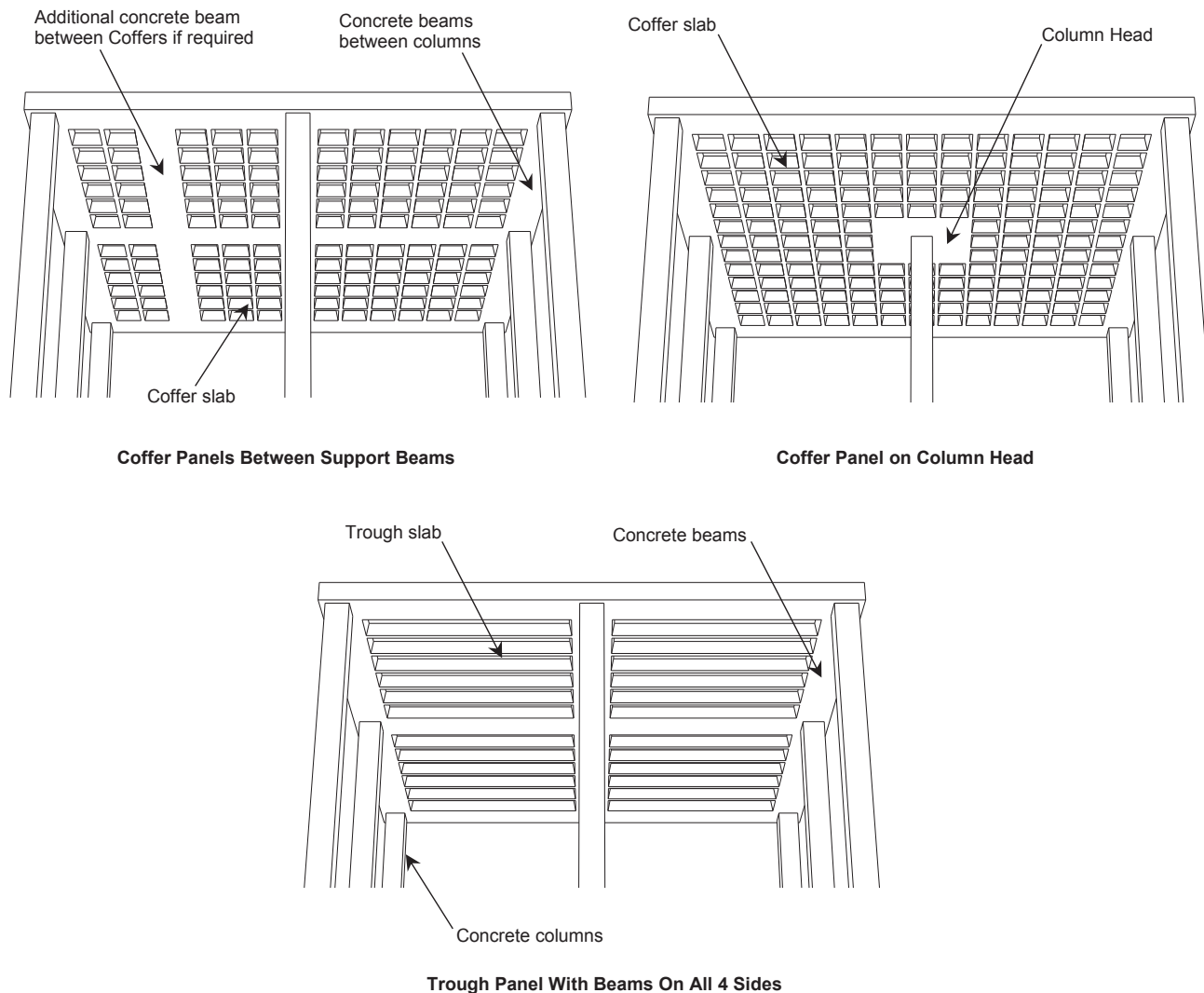

Figure 1 – Examples Of Coffer And Trough Configurations

STRUCTURAL CONSIDERATIONS AND ADVANTAGES

General design considerations

- The reinforced concrete design portion of this Concrete Design Guide excludes:
 - Seismic loads
 - Wind loads
 - Point loads on the slabs.
- The above loads are specific conditions which, where applicable, need to be considered in design calculations for the structure as a whole.
- The analysis of the reinforced concrete frame and the redistribution of moments at fixed joints and at continuous spans are in accordance with Clause 4.2 of the SANS 0100-1.
- An allowance for a change of the percentage redistribution of moments is an individual preference which must be determined by each structural engineer.
- A Coffers slab should be regarded as a two-way spanning integral beam and slab design where no down-stand beams are required.
- A Trough slab should be regarded as a one-way spanning integral beam and slab design where no down-stand beams are required.
- In addition to the reference documentation listed on Page 2, reinforced concrete designs must be done in accordance with:
 - Generally accepted design principles.
 - Reinforced concrete design software.
- The span to depth ratios for slabs shall be in accordance with the requirements of Clause 4.4.6 of the SANS 0100-1.
- Cambers may be built into the in-situ concrete slabs to compensate for the deflection of the slabs due to self weight and design loads.
- The stiffening effect of columns above or below the concrete slab have been ignored in this Concrete Design Guide.
- Final analysis and design of the concrete for Coffers or Trough slabs must be carried out by a suitably qualified professional, competent in reinforced concrete design.
- Whilst every care has been taken to ensure that the information provided in this Concrete Design Guide is accurate and well founded on principles of standard design, it must be noted that this Concrete Design Guide is used to provide guidance only for the preliminary selection of a Coffer or Trough configuration for the concrete slab that is being designed.

Structural advantages

Coffers and Troughs provide the following structural advantages:

- Improved concrete span to depth ratio.
- Reduced amount and weight of concrete. Refer to Tables 3, 16 and 17 for the approximate displacement values.
- Reduced amount of reinforcing steel.
- Reduced column sizes.
- Reduced foundation loading resulting in smaller foundations.

Concrete mass

The mass of reinforced concrete for Coffer and Trough slabs is assumed to be 25 kN/m³.

To compensate for the possibility of an excessive screed thickness being applied, the mass of the non-structural screed over the Coffer and Trough slabs is also assumed to be 25 kN/m³.

The screed over the Coffers and Troughs (usually 50 mm thick), is non-structural and primarily used to level the top of the concrete slab.

An allowance for the self-weight of the screed over the Coffers and Trough slabs must be made when calculating the overall weight and deflection of the concrete elements.

Concrete and mass reduction values

The inclusion of Coffers and Troughs results in having the concrete and dead weight reduction values given in Table 1.

* Excludes the volume for tapered ends of the Troughs.

Table 1 - Concrete And Mass Reduction Values				
	Coffer/Trough Size (mm)	Concrete Reduction (m ³ /m ²)	*Concrete Reduction (m ³ /m)	Dead Weight Reduction (kN/m ²)
Coffers	525	0.286	-	7.150
	425	0.248	-	6.200
	325	0.207	-	5.175
	225	0.144	-	3.600
Troughs	625	-	0.370	9.250
	525	-	0.332	8.300
	425	-	0.278	6.950
	325	-	0.214	5.350
	225	-	0.152	3.800

Shear

Where the beams intersect the columns, high localized forces occur and punching shear is the main cause for concern.

The shear resistance of beams must be in accordance with Clause 4.3.4 of the SANS 0100-1.

Deflection

Deflection at any point along the theoretical neutral axis of a structural element is the measured distance from the theoretical neutral axis to the final position of the axis after loading and this measured distance must be within the allowed serviceability limit of the element.

The serviceability limit of each designed concrete element is to be in accordance with the specifications given in Clause 4.3.6 of the SANS 0100-1.

An allowance for the upward cambers of the slab and beams is recommended to compensate for the downward elastic deflections under self-weight conditions.

Cover to reinforcing steel

Cover to reinforcing steel is the least distance between the outer surface of the concrete and the embedded reinforcing steel and is required to protect the steel against corrosion and provide resistance against fire as specified in Clause 4.11.2 and Clause 7 of the SANS 0100-1.

COFFER SLAB DESIGN

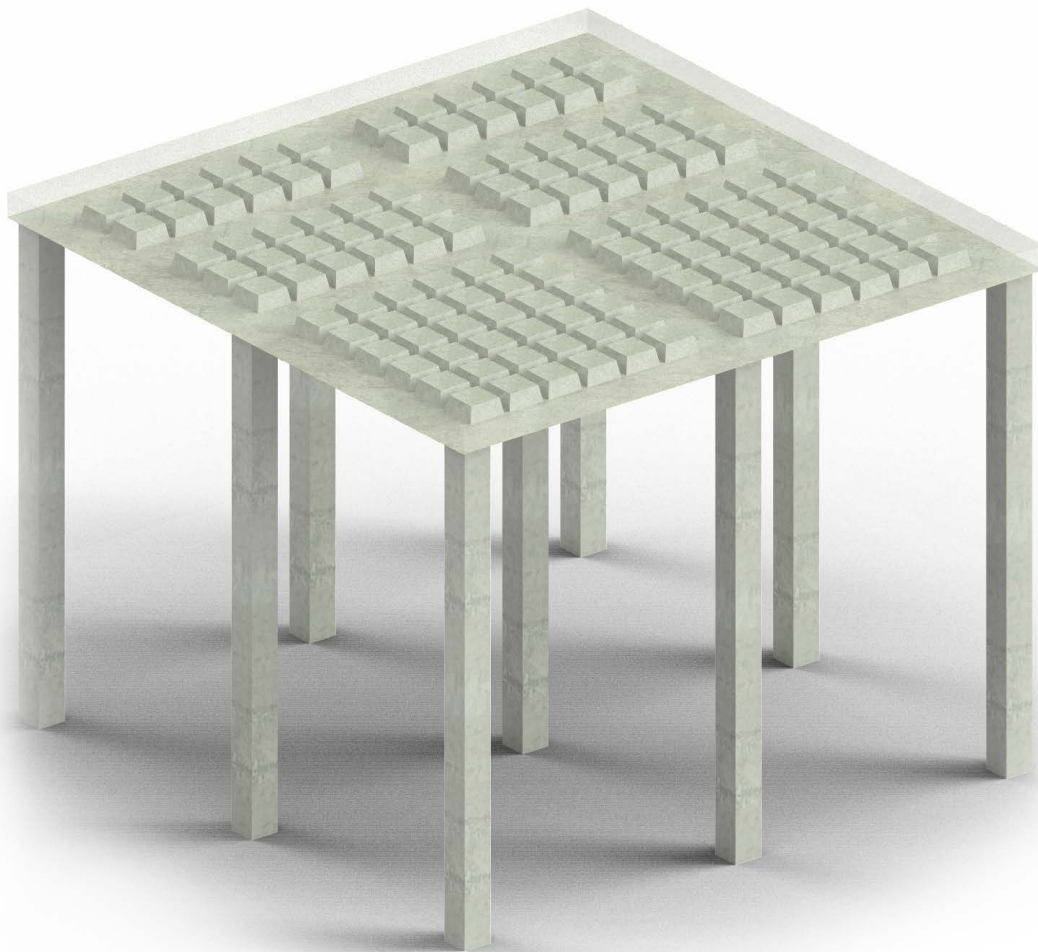

COFFER AND TROUGH SLAB DESIGN

COFFER SLAB DESIGN

Design procedure

To simplify the design of Coffer slabs, a recommended step by step procedure is given in Table 2 below.

Steps 1 to 50 given in Table 2 are explained in more detail on Pages 10 to 54.

Table 2 should also be used in conjunction with the "Design Flow Diagram" shown on Page 7.

Table 2 - Step By Step Design Procedure For Coffers Slabs			
Coffer support beam and slab identification	Identify and determine the layout of the Coffer slab and support beams	Step 1	Fill the complete slab with Coffers while leaving a beam around the perimeter of the floor slab
		Step 2	Identify all the load bearing walls that are supported on top of the slab
		Step 3	Identify the main columns and load bearing walls below the slab
		Step 4	Check if any further support beams are required to create two-way spanning slabs
		Step 5	Identify all the columns and preliminary support beams
	Determine thickness of the Coffer slab and support beams	Step 6	Identify the support beam with the worst-case deflection scenario based on the L/d values
		Step 7	Determine the required slab thickness due to deflection
		Step 8	Determine the Coffer height and structural topping thickness
	Determine the self-weight and imposed loads	Step 9	Determine the self-weight of the slab
		Step 10	Determine the self-weight of the support beam
		Step 11	Determine the imposed loading acting on the slab and support beam
		Step 12	Determine the loads acting on the slab and support beam
Coffer support beam design	Determine the loads acting on the support beams	Step 13	Identify the coffer configuration acting on the support beam
		Step 14	Determine the impact of Coffer slabs acting on the support beam
		Step 15	Determine the total load acting on the support beam
	Determine the mid-span moments and the tension reinforcing steel required	Step 16	Determine the maximum mid-span bending moment for the support beam
		Step 17	Determine the moment of resistance for the support beam
		Step 18	Determine the area of tension reinforcing steel required for the support beam at mid-span
		Step 19	Select the spacing and type of tension reinforcing steel to be used for mid-span bending
	Determine the shear reinforcing steel required	Step 20	Determine the required number of stirrups
		Step 21	Checking the shear resistance of the support beam
		Step 22	Determine the spacing of stirrups
	Determine the support moments and the tension reinforcing steel required	Step 23	Determine the maximum support bending moment for the support beam
		Step 24	Determine the area of tension reinforcing steel required for the beam at the support
		Step 25	Select the spacing and type of tension reinforcing steel to be used for support bending
	Check the deflections for the support beam	Step 26	Check the deflections based on the basic allowable span
		Step 27	Calculate the actual long-term deflections
	Steel detailing of the support beam	Step 28	Steel detailing of mid-span tension reinforcing steel for the support beams
		Step 29	Steel detailing of the stirrups for the support beams of the Coffer slab
		Step 30	Steel detailing of support beam tension reinforcing steel and nominal top reinforcing steel at mid-span
Coffer ribs/slab design	Identify the Coffer configuration and the minimum structural topping thickness	Step 31	Identify and name the Coffer portions between the support beams
		Step 32	Select a Coffer portion and identify specific details from the drawing
		Step 33	Determine the minimum structural topping thickness due to deflection for selected Coffer height
	Determine the loads acting on the Coffer slab	Step 34	Determine the self-weight of the Coffer slab and imposed loads on the Coffer slab
		Step 35	Determine the span end conditions and maximum moments of the Coffer slab
	Determine the end conditions, mid-span moment resistance and the tension reinforcing steel required for each rib	Step 36	Determine the moment of resistance of each Coffer rib
		Step 37	Determine the area of tension reinforcing steel required for each rib at mid-span
		Step 38	Select the spacing and type of reinforcing steel to be used for the ribs to cater for mid-span bending
		Step 39	Select the number of stirrups for the ribs
	Determine the shear reinforcing steel required	Step 40	Check the shear resistance of the rib
		Step 41	Determine the spacing of the stirrups in the ribs
		Step 42	Determine the area of nominal reinforcing steel at mid-span and at the supports for the Coffer slab
	Determine the reinforcing steel required at mid-span and supports	Step 43	Determine the area of tensile reinforcing steel required for the rib at the support beam
		Step 44	Select the spacing and type of tensile reinforcing steel to be used at the rib support for bending
		Step 45	Check the deflections based on the basic allowable span of the ribs
	Check deflections for the Coffer slab	Step 46	Calculate actual long-term deflections of the ribs
		Step 47	Steel detailing of midspan tension reinforcing steel for the ribs
	Steel detailing of the Coffer slab	Step 48	Steel detailing of the stirrups for the ribs of the Coffer slab
		Step 49	Steel detailing of the nominal reinforcing steel at mid-span and the supports for the Coffer slab
		Step 50	Steel detailing of tension reinforcing steel at the support and the nominal top reinforcing steel at mid-span

COFFER SLAB DESIGN

Design Flow Diagram

The Design Flow Diagram below shows the recommended step by step procedure for designing Coffer slabs. This step by step procedure should also be used in conjunction with Table 2.

Legend

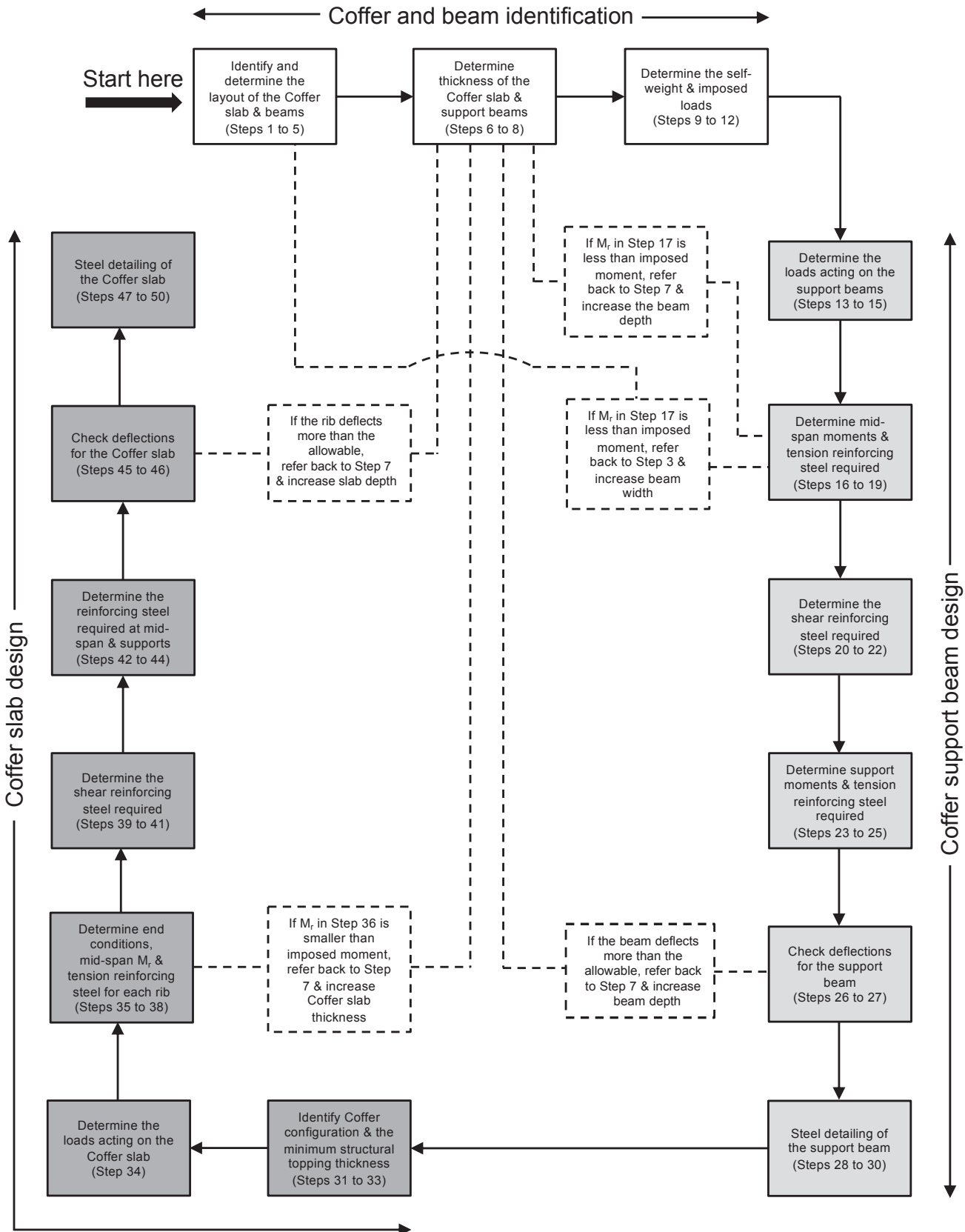
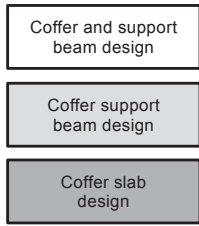

Design Flow Diagram

COFFER SLAB DESIGN

Coffer dimensions and displacement values

Table 3 gives the dimensions and approximate displacement values of the 4 No. available sizes of Coffers.

The base of each Coffer is 900 mm x 825 mm (not square in plan). Half the width of the Kwik-Strip beam on each side of the Coffer is added to the 825 mm width of the Coffer to make up the difference of 75 mm. (Refer to the Form-Scaff Technical User Guide for details)
The upper portion of the Coffer that forms the void in the concrete is square in plan.

All 4 sides of the Coffers are at a 5:1 slope, or 11.31° angle.

Figure 2 shows the approximate dimensions of the Coffers.

The dimensions to the curved surfaces, shown in the diagrams, are to the intersection point of the straight edges.

A 10% tolerance on the displacement values should be taken into consideration due to following reasons:

- Manufacturing variances.
- Repair work and imperfections due to the age of the Coffers.
- Temperature variations.
- Coffer movement due to rapid rate of pour.
- Deflection of the fiberglass facing due to the mass of concrete and reinforcing steel.

Note:

Only Form Coffers must be used (not the older Glassfibre type Coffers).

The maximum thickness of structural topping permitted on the Form Coffers = 250 mm.

The maximum thickness of non-structural screed permitted on the structural topping = 75 mm.

The total permitted thickness of the structural topping plus the non-structural screed = 325 mm.

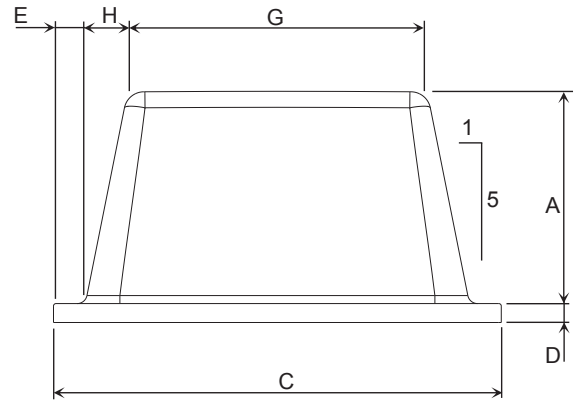

Side View A - A

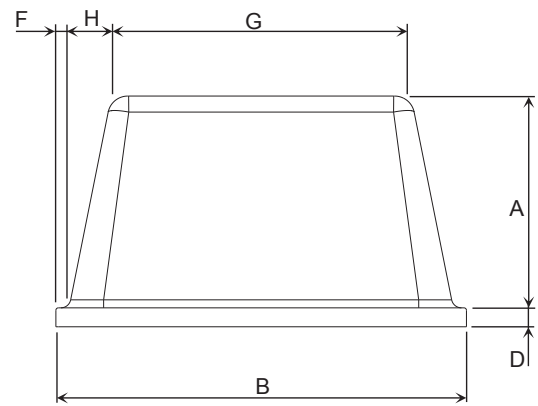

Side View B - B

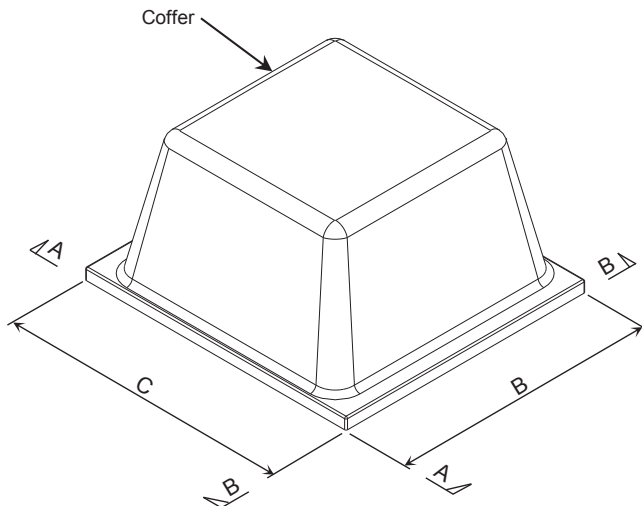

Coffer - 3D View

Figure 2 – Side Views and 3D View Of Coffers

Table 3 - Coffer Dimensions And Approximate Displacement Values

Coffer Size (mm)	Coffer Dimensions (mm)								Coffer Displacement (m ³)
	A	B	C	D	E	F	G	H	
525	525	825	900	38	64	26	562	105	0.232
425	425	825	900	38	64	26	602	85	0.201
325	325	825	900	38	64	26	642	65	0.168
225	225	825	900	38	64	26	682	45	0.117

COFFER SLAB DESIGN

Design Example

The Coffers design procedure given in this Concrete Design Guide is based on an example where the following assumptions have been made:

- The architect has requested a Coffer alternative to a solid slab solution, which will be significantly lighter in weight and more economical.
- The floor slabs are to be designed for a building consisting of residential dwelling units along the coastline of Cape Town.
- The floor slabs are to be supported on 400mm x 400mm columns.
- The imposed loads on the floor slab are based on a “sub-category B5” (Refer to SANS 10160-2, Table 1 for the different categories and specific uses).
- A concrete compressive strength of 30 MPa and a tensile reinforcing steel strength 450 MPa is being used throughout the remainder of the building and should be used for the floor slabs where possible.
- To cater for fire resistance, the floor slabs must be designed in accordance with the SABS 0100-1, Clause 7.

A portion of the Coffer slab, described in the abovementioned example, is shown in Figure 3 below.

The design example mainly concentrates on the design of Beam 7 and the Coffer portion between Beams W and Y.

Other portions of the Coffer slab shown in Figure 3 will only be discussed for clarification purposes as and when necessary.

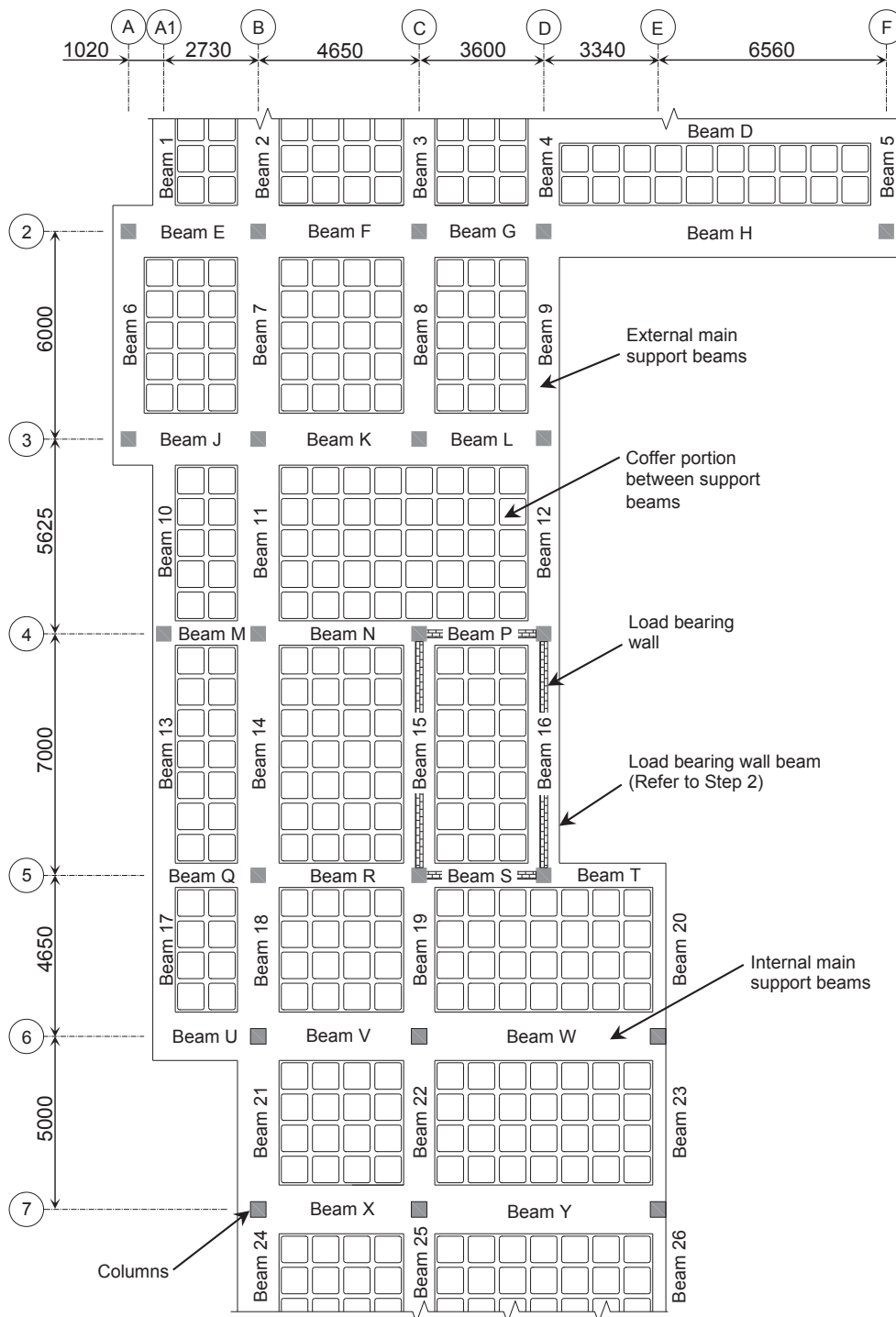

Figure 3 – Typical Example Of A Coffer Slab Supported On Columns

COFFER SLAB DESIGN

PART 1 – Coffers and support beam identification (Steps 1 to 12)

The designer is not limited to designing a Coffers slab using the following Steps 1 to 50 and may use any other preferred design method. Prior to starting with Step 1, the designer should familiarize himself/herself with the architectural drawings.

Step 1: Fill the complete slab with Coffers while leaving a beam around the perimeter of the floor slab.

This is done to simplify the layout and ensure that the spacing of the Coffers line up with each other (As shown in Figure 3).

The designer may deviate from Step 1 if a different Coffers layout is preferred due to other influences such as point loads on the slab.

The width of the internal support beams may be anything from 500 mm upwards.

The width of the support beams around the perimeter must be determined by the designer to suit the architectural and structural requirements.

The width and depth of each support beam must be verified, taking into consideration all applied dead and imposed loads.

Step 2: Identify all the load bearing walls that are supported on top of the slab.

In addition to supporting the required design loads, the designer should consider that the slab may also be required to support additional loads such as from walls on top of the slab.

Draw the load bearing walls on the layout and remove all the coffers directly below the walls to form 'load bearing wall beams' (For example, Beam 15 shown in Figure 3).

This immediately allows for a 900 mm support beam directly below each load bearing wall.

The width and depth of each support beam must be verified, taking into consideration all applied dead and imposed loads.

Step 3: Identify the main columns and load bearing walls below the slab.

Remove the rows of Coffers between the columns/wall supports to establish the 'main support beams' (As shown in Figure 3).

The width and depth of each 'main support beam' must be verified, taking into consideration all dead and imposed loads.

'Load bearing wall beams' must be introduced to support the load bearing walls that do not fall directly on the 'main support beams'.

The ends of the 'load bearing wall beams' are supported by the 'main support beams' and act as point loads on the 'main support beams'.

Step 4: Check if any further beams are required to create two-way spanning slabs.

The designer now has a basic layout to determine support beam widths, support widths and support conditions. (As shown in Figure 3).

In most cases, the spacing does not work out exactly as per the Coffers and Decking Panel dimensions, thus the designer is required to move the Coffers around on the layout to try and get the supports as central as possible between two Coffers configurations.

The internal support beam widths should be 1500 mm, 1294 mm or 900 mm where possible to accommodate the Decking Panel sizes of 1425 mm, 1219 mm and 825 mm.

When this is not possible, infills or non-standard equipment will be required to form the soffit of the support beams which will have cost implications and increase the erection time of the falsework.

Step 5: Identify all the columns and preliminary support beams.

For example, the columns may be identified using the grid lines (Column A1, Column B1, etc.) and the support beams identified as shown in Figure 3.

These references identify each concrete element that is being designed and will be used when scheduling the reinforcing steel.

COFFER SLAB DESIGN

Step 6: Identify the support beam with the worst-case deflection scenario based on the L/d values given in Table 4.
 To determine the effective depth of the Coffe slab, it is necessary to compare the different support beam configurations within the slab. At this stage, only consider the self weight and ignore imposed loads.

This may be achieved by Applying the formula:

$$\frac{\text{Span Length 'L' (mm)}}{\text{Ratio}} = d \text{ (mm)}.$$

Where:

The Span Length 'L' is the distance between the centre lines of the supports.
 In the case of a cantilever beam, the Span Length 'L' is the distance between the centre line of the support and the end of the cantilever beam.

For each beam configuration, the Span Length 'L' of the relevant beam between supports must be determined (using the drawing) and the relevant ratio selected from Table 4.

To determine the worst-case scenario, the following 3 examples deal with different beam configurations within a typical Coffe slab.

Beam configuration 1:
 Consider a beam with both ends continuous where L = 7000 mm (For example, Beam 14 shown in Figure 3)

$$\frac{7000 \text{ mm}}{28} = d = 250 \text{ mm}.$$

Beam configuration 2:
 Consider a truly simply supported beam where L = 6000 mm (For example, Beam 6 shown in Figure 3)

$$\frac{6000 \text{ mm}}{16} = d = 375 \text{ mm}.$$

Beam configuration 3:
 Consider a beam with one end continuous where L = 7000 mm (For example, Beam 16 shown in Figure 3)

$$\frac{7000 \text{ mm}}{24} = d = 292 \text{ mm}.$$

From the example above, it can be seen that it is not always the longest span that results in the biggest deflection, but the deflection is also dependent on the support conditions and obviously the imposed loading.

The designer is required to calculate the effective depth 'd' for all the different scenarios applicable to the specific layout drawing.

The largest effective depth 'd' is then used to determine the slab thickness 't' for the whole slab.

Normally the slab thickness remains constant over the complete floor area, except where a definitive difference between spans or loads occur and the designer opts for a thicker or thinner slab in a specific portion due to structural or financial constraints.

Support Conditions	Ratio
Truly simply supported beams	16
Simply supported beams with nominally restrained ends	20
Beams with one end continuous	24
Beams with both ends continuous	28
Cantilevers	7

(Reference SABS 0100-1 Ed.2.2, Table 10)

COFFER AND TROUGH SLAB DESIGN

COFFER SLAB DESIGN

Step 7: Determine the required slab thickness 't' due to deflection.

The following example may be used to determine the slab thickness due to deflection:

Example:

From Step 6, beam configuration 2 has the biggest effective depth 'd' of 375 mm and must therefore be used to determine the required slab thickness 't'

Assume Y16 reinforcing bars and R8 stirrups will be used for this example
The actual diameter of the reinforcing bars must be checked later and be replaced if necessary, in the calculation below

Assume the cover to reinforcement = 30 mm
The cover must be determined in accordance with the requirements of the structure and SANS 0100-1 Ed. 2.2 Clause 4.5.7

Required slab thickness 't' = effective depth 'd' + cover to reinforcement + half the diameter of main reinforcing bars selected + the diameter of the stirrups (diameter_{stirrup})

$$t = 375 \text{ mm} + 30 \text{ mm} + (16 \text{ mm} \div 2) + 8 \text{ mm} = 421 \text{ mm.}$$

Step 8: Determine the Coffers height and structural topping thickness.

The total Coffers height plus the structural topping thickness is equal to the slab thickness 't' and the beam height between the Coffers sections.

The 4 No. available heights of Coffers are given in Table 5 (Coffer Size mm).
Also refer to dimension 'A' in Table 3

The minimum structural topping thickness for each of the Coffer sizes are given in Table 5.
The minimum structural topping thickness should also be the greater of 50 mm or one-tenth of the clear span between ribs as given in SABS 0100-1 Ed.2.2, Clause 4.5.1.2(d).

The designer should select a compliant Coffer size which will yield the least volume of concrete per m².

Different Coffer sizes are compared in the following scenarios.

Example:

For illustration purposes, assume the floor area consists of 10 No. Coffers (Refer to the Coffer slab between grid lines A1 and B / 3 and 4 in Figure 3)

Minimum slab thickness 't' = 421 mm (From Step 7)

Floor Area = 10 Coffers x (0.9 m x 0.9 m in plan) = **8.1 m²**.

Coffer Size (mm)	Coffer Displacement (m ³)	Clear Distance Between Ribs (mm)	Minimum Structural Topping Thickness (mm)	Maximum Structural Topping Thickness (mm)
525	0.232	562	56	250
425	0.201	602	60	250
325	0.168	642	64	250
225	0.117	682	68	250

*Refer to dimension 'G' in Table 3 and Figure 14

Scenario 1 using 225 Coffers:

Slab thickness of 421 mm – 225 mm Coffer = **196 mm** topping > 68 mm and < 250 mm topping thickness (From Table 5, meets requirements)

Volume of concrete without Coffers = 8.1 m² x 0.421 mm = **3.410 m³**

Displacement of 10 No. x 225 mm Coffers = 10 x 0.117 m³ = **1.170 m³**

Volume of concrete with 225 mm Coffers + 196 mm topping = **2.240 m³**.

Scenario 2 using 325 Coffers:

Slab thickness of 421 mm – 325 mm Coffer = **96 mm** topping > 64 mm and < 250 mm topping thickness (From Table 5, meets requirements)

Volume of concrete without Coffers = 8.1 m² x 0.421 mm = **3.410 m³**

10 No. x 325 mm Coffer displacement = 10 x 0.168 m³ = **1.680 m³**

Volume of concrete with 325 mm Coffers + 96 mm topping = **1.730 m³**.

Scenario 3 using 425 Coffers:

Slab thickness of 421 mm – 425 mm Coffer = **- 4 mm** topping < 60 mm and < 250 mm topping thickness (From Table 5, topping not thick enough).

Scenario 4 using 525 Coffers:

Slab thickness of 421 mm – 525 mm Coffer = **- 104 mm** topping < 56 mm and < 250 mm topping thickness (From Table 5, topping not thick enough)

Note:

From above, it can be seen that **Scenario 2** is the most economical design.

If a solid slab was used as opposed to a Coffer slab, the volume of concrete for a 421 mm thick flat slab = 8.1 m² x 421 mm = **3.410 m³**.

If **Scenario 2** is used instead of a flat slab, the concrete and reinforcing will be reduced by **49.3%** in the Coffer slab portions.

COFFER SLAB DESIGN

Prior to moving on to Step 9, a method of calculating the volume and mass of a Coffer slab should be established. This volume and mass excludes the concrete support beams around the edges of the slab and the non-structural screed.

Example: (Portion of the Coffer slab from Figure 3)

Calculate the total volume and mass of a Coffer slab that consists of 10 No. 325 Coffers in one direction and 2 No. 325 Coffers in the other direction.

Referring to Figure 4 below, determine the plan area:

Each Coffer is 0.9 m x 0.9 m in plan

Therefore, the total plan area of the Coffer slab = (0.9 m x 10 Coffers) x (0.9 m x 2 Coffers) = 9.0 m x 1.8 m = **16.2 m²**

Determine the overall thickness of the concrete slab:

Height of Coffer = 325 mm (From Table 3, dimension 'A')

Assumed thickness of the structural topping = 100 mm (Maximum thickness = 250 mm)

Therefore concrete thickness = 325 mm + 100 mm = **425 mm**

Determine the volume of the equivalent solid concrete slab (Excluding the voids formed by the Coffers):

Volume = (Plan area) x (Concrete thickness) = 16.2 m² x 0.425 m = **6.885 m³**

Determine the volume of the concrete displaced by the Coffers:

The displacement value of 1 No. 325 Coffer = 0.168 m³ (From Table 3)

Number of Coffers = 10 x 2 = 20 No.

Total volume of displaced concrete = 0.168 m³ x 20 Coffers = **3.360 m³**

Determine the volume of concrete for the Coffer slab:

The total volume of concrete for the complete slab = 6.885 m³ – 3.360 m³ = **3.525 m³**

Therefore, the volume of concrete = 3.525 m³ ÷ 16.2 m² = **0.218 m³** per m² in plan.

Determine the mass of the Coffer slab:

Mass of reinforced concrete = 25 kN/m³ (Assumed)

The total mass of concrete for the complete slab = 3.525 m³ x 25 kN/m³ = **88.125 kN**

Therefore, the mass of the concrete slab = 88.125 kN ÷ 16.2 m² = **5.440 kN** per m² in plan.

Note:

The designer must allow for the additional mass of a non-structural screed over the entire area of the slab (Usually between 20 and 75 mm thick).

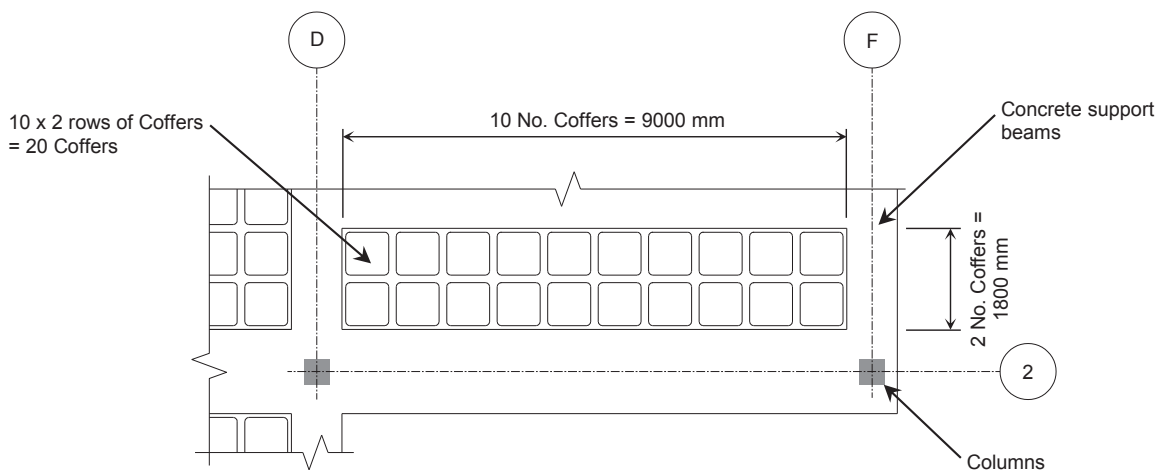

Figure 4 – Typical Plan View Of Coffer And Support Beam Layout
(Extract from Figure 3)

COFFER SLAB DESIGN

Step 9: Determine the self-weight of the slab.

The designer needs to determine the self-weight of the Coffers portions to determine the dead load acting on the support beams.

The assumption is made that the weight per Coffer portion is directly related to the weight per square metre of Coffer slab.

Example:

Coffer height + structural topping = 325 mm Coffer + 96 mm structural topping = **421 mm** (From Step 8, Scenario 2)

Round off the 96 mm structural topping to **100 mm**

Therefore, minimum slab thickness 't' = **425 mm**

325 mm Coffer concrete displacement = 0.168 m³ per Coffer (From Table 3)

Allow for a 50 mm thick non-structural screed with the same density as concrete

Concrete volume per Coffer area = ((0.325 m + 0.100 m + 0.050 m) x (0.9 m x 0.9 m in plan)) - 0.168 m³ = **0.217 m³** per Coffer

Concrete volume = [0.217 m³ ÷ (0.9 m x 0.9 m in plan)] x (1.0 m x 1.0 m in plan) = **0.268 m³/m²** in plan

Concrete density = 25 kN/m³ (Refer to SANS 10160-2, Table A.1)

Therefore, the self weight of the Coffer portion of the slab = 0.268 m³/m² x 25 kN/m³ = **6.700 kN/m²** in plan.

Step 10: Determine the self-weight of the support beam.

The designer needs to determine the self-weight of the support beam in the same manner as described in Step 9.

The only difference is that there is no deduction due to Coffer displacement and the full depth of the Coffer and structural topping is taken into consideration when calculating the support beam depth and self-weight per m² in plan.

Example:

Minimum slab thickness 't' = 425 mm (From Step 9)

Concrete density = 25 kN/m³ (From Step 9)

Allow for a 50 mm thick non-structural screed with the same density as concrete

Concrete volume = (0.425 m + 0.050 m) x (1.0 m x 1.0 m in plan) = **0.475 m³/m²**

Therefore beam self-weight = 0.475 m³/m² x 25 kN/m³ = **11.875 kN/m²** in plan.

Step 11: Determine the imposed loading acting on the slab and support beam.

The designer needs to identify the specific use for every section of the building.

Refer to SANS 10160-2, Table 1 for the different categories and specific uses.

The same building may have several different uses in different portions of the building.

An example of this is when a filing room is next to a classroom in a school.

The designer can choose to cater for the worst-case scenario throughout the building, but that may lead to an uneconomical design.

Step 12: Determine the loads acting on the slab and support beam.

For the slab and support beam design, use the ultimate limit state factors as specified in SANS 10160-1, Table 3.

Permanent actions (Dead Load) such as the self-weight of the beam or slab itself, screed, tiles, etc. are multiplied by a partial factor of 1.2.

Variable actions (Live Load) such as the imposed loads acting on the floor or roof are multiplied by a partial factor of 1.6.

These are then added together to determine a design load as shown below.

$$w = 1.2 \times (\text{Sum of Dead Loads}) + 1.6 \times (\text{Sum of Live Loads})$$

Example:

Coffer height + structural topping + non-structural screed = 325 mm Coffer + 100 mm structural topping + 50 mm screed = **475 mm** (From Step 9)

Beam self-weight = 11.875 kN/m² (From Step 10)

Assume that the building consists of dwelling units, thus the imposed load = 1.5 kN/m² (Refer SANS 10160-2, Table 1)

Coffer slab self-weight = 6.700 kN/m² in plan (From Step 9)

$$w_{\text{slab}} = (1.2 \times 6.700 \text{ kN/m}^2) + (1.6 \times 1.5 \text{ kN/m}^2) = \mathbf{10.440 \text{ kN/m}^2} \text{ in plan}$$

Beam self weight = 11.875 kN/m² in plan (From Step 10)

$$w_{\text{beam}} = (1.2 \times 11.875 \text{ kN/m}^2) + (1.6 \times 1.5 \text{ kN/m}^2) = \mathbf{16.650 \text{ kN/m}^2} \text{ in plan.}$$

COFFER SLAB DESIGN

PART 2 – Coffer support beam design (Steps 13 to 30)

Step 13: Identify the Coffer configuration acting on the support beam.

The layout for the Coffers and beams should look similar to the typical layouts shown in Figures 5 and 6.

The designer needs to isolate each support beam and determine the Coffer configuration associated with that specific beam.

The configuration of the Coffer portion is of importance because it influences the number of Coffers acting on a specific beam.

SABS 0100-1 Ed.2.2, Clause 4.4.4.3 states that if two slabs having the same supporting conditions meet at a corner, the dividing angle is 45 degrees.

The same clause also states that if a fully restrained edge meets a freely supported edge, the dividing angle on the restrained side is 60 degrees.

For Coffer design, assume the dividing angle to be 45 degrees.

The two scenarios below show the number of Coffers supported by a specific beam.

Scenario 1:

Figure 5 below (Portion of the Coffer slab from Figure 3) shows 2 rows of 10 Coffers = 20 Coffers between the surrounding support beams.

The end Coffers are divided by a 45 degree line whereby half the weight of the divided end Coffers are carried by support beams D and H and half the weight of the divided end Coffers are carried by support beams 4 and 5.

Beam D is supporting 8 complete Coffers plus half of the end Coffers = 8 Coffers + ½ Coffer + ½ Coffer = Equivalent to 9 Coffers

Beam H is supporting 8 complete Coffers plus half of the end Coffers = 8 Coffers + ½ Coffer + ½ Coffer = Equivalent to 9 Coffers

Beam 4 is supporting ½ Coffer + ½ Coffer = Equivalent to 1 Coffer

Beam 5 is supporting ½ Coffer + ½ Coffer = Equivalent to 1 Coffer.

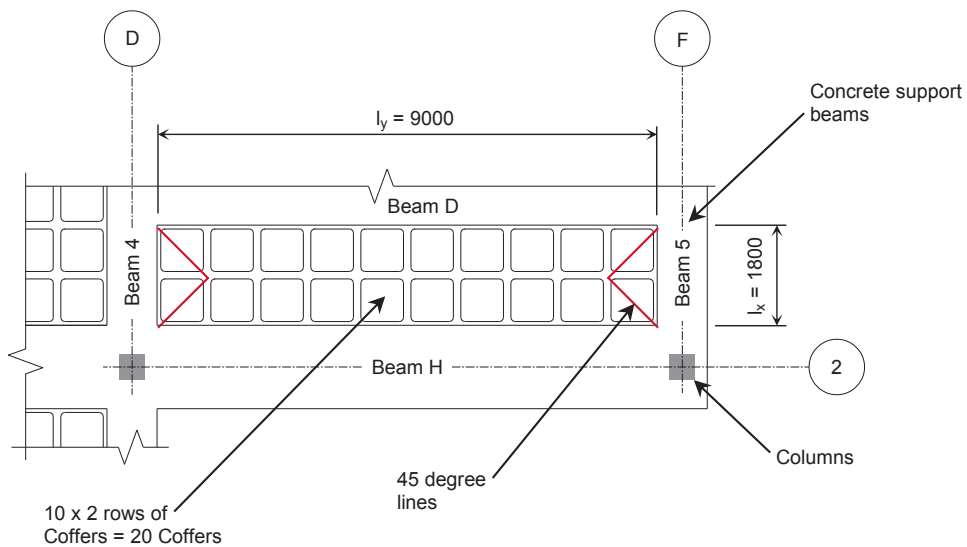

Figure 5 – Typical Plan View Of Coffer And Support Beam Layout (Extract from Figure 3)

COFFER AND TROUGH SLAB DESIGN

COFFER SLAB DESIGN

Scenario 2:

Figure 6 below (Portion of the Coffer slab from Figure 3) shows 4 rows of 5 Coffers = 20 Coffers between the surrounding support beams.

The end Coffers are divided by a 45 degree line whereby half the weight of the 2 divided end Coffers are carried by beams 7 and 8 and half the weight of the 2 divided end Coffers are carried by beams F and K.

Beam 7 is supporting 4 complete Coffers plus 4 half Coffers = 4 Coffers + ½ Coffer + ½ Coffer + ½ Coffer + ½ Coffer = Equivalent to 6 Coffers

Beam 8 is supporting 4 complete Coffers plus 4 half Coffers = 4 Coffers + ½ Coffer + ½ Coffer + ½ Coffer + ½ Coffer = Equivalent to 6 Coffers

Beam F is supporting 2 complete Coffers plus 4 half Coffers = 2 Coffers + ½ Coffer + ½ Coffer + ½ Coffer + ½ Coffer = Equivalent to 4 Coffers

Beam K is supporting 2 complete Coffers plus 4 half Coffers = 2 Coffers + ½ Coffer + ½ Coffer + ½ Coffer + ½ Coffer = Equivalent to 4 Coffers.

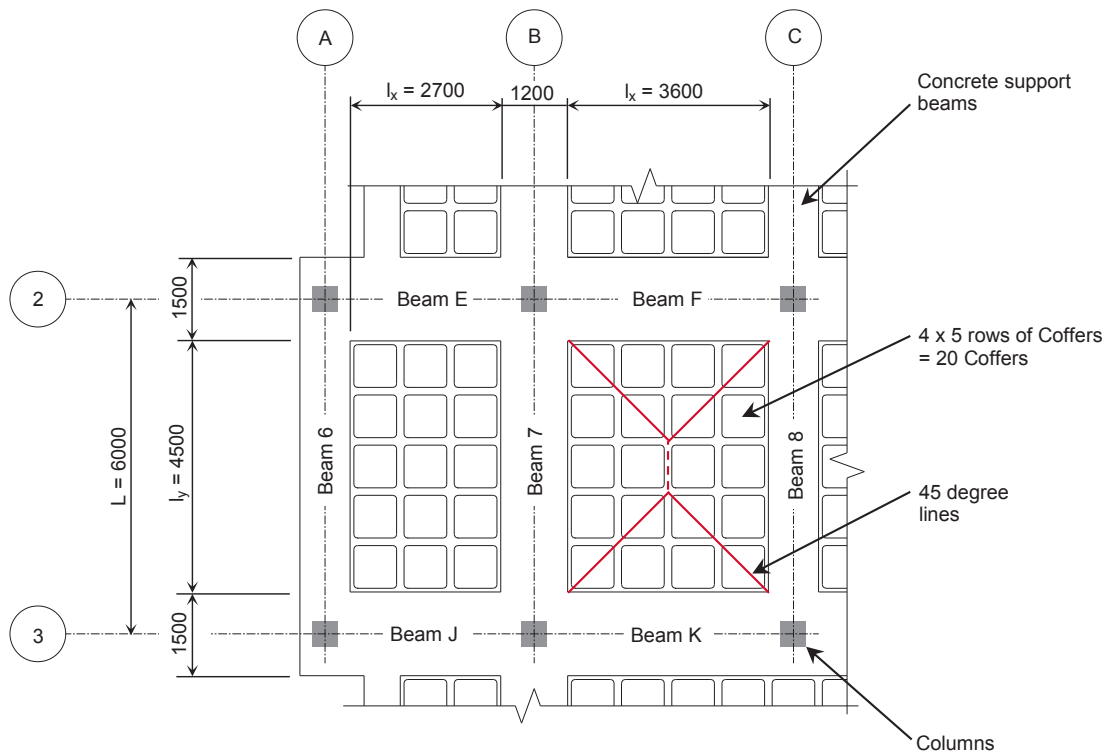

Figure 6 – Typical Plan View Of Coffer And Support Beam Layout
(Extract from Figure 3)

Note:

It can be seen from scenarios 1 and 2 above that even though two slabs can have the same number of Coffers (20 No.), the Coffer configuration influences the number of Coffers acting on each respective support beam.

COFFER SLAB DESIGN

Step 14: Determine the impact of Coffer slabs acting on the support beam.

The layout of the Coffers and beams should look similar to the layout shown in Figure 3.

From Figure 5 and Figure 6, it can be seen that the load distribution will be either in a trapezoidal or triangular shape, depending on the length of the sides of the slab.

For example, in Figure 6, Beam F has a load distribution from the slab that is triangular in shape, while Beam 7 has a load distribution acting from the slab that is trapezoidal in shape.

It must be noted that even if the load from the Coffer slab is a trapezoidal or triangular shape, it is assumed to be a uniformly distributed load over the length of the support beam.

The Coffer/slab configuration on the other side of each respective support beam must also be considered when determining the total load acting on each beam.

If for example, there is a slab on the other side of Beam 7 (Shown in Figure 6), the load action from that slab must also be added to Beam 7.

To determine the load acting on a beam, refer to the formulas and example below.

$$\text{Trapezoidal load } w = \frac{nl_x}{6} \left(3 - \left(\frac{l_x}{l_y} \right)^2 \right)$$

$$\text{Triangular load } w = \frac{nl_x}{3}$$

Example:

Beam 7 (Refer to Figure 6):

$$n \text{ (Load on slab)} = w_{\text{slab}} = 10.440 \text{ kN/m}^2 \text{ (From Step 12)}$$

$$l_x \text{ (Length of shorter side of the slab between Beams 6 and 7)} = 3 \text{ No.} \times 900 \text{ mm wide Coffers} = \mathbf{2700 \text{ mm}} \text{ (Refer to Figure 6)}$$

$$l_y \text{ (Length of longer side of the slab between Beams 6 and 7)} = 5 \text{ No.} \times 900 \text{ mm wide Coffers} = \mathbf{4500 \text{ mm}} \text{ (Refer to Figure 6)}$$

$$\text{Trapezoidal load } w = \frac{nl_x}{6} \left(3 - \left(\frac{l_x}{l_y} \right)^2 \right) = \frac{10.440 \text{ kN/m}^2 \times 2.7 \text{ m}}{6} \left(3 - \left(\frac{2.7 \text{ m}}{4.5 \text{ m}} \right)^2 \right) = \mathbf{12.403 \text{ kN/m}} \text{ on Beam 6 side of Beam 7.}$$

$$l_x \text{ (Length of shorter side of the slab 'l}_x\text{' between Beams 7 and 8)} = 4 \text{ No.} \times 900 \text{ mm wide Coffers} = \mathbf{3600 \text{ mm}} \text{ (Refer to Figure 6)}$$

$$l_y \text{ (Length of longer side of the slab 'l}_y\text{' between Beams 7 and 8)} = 5 \text{ No.} \times 900 \text{ mm wide Coffers} = \mathbf{4500 \text{ mm}} \text{ (Refer to Figure 6)}$$

$$\text{Trapezoidal load } w = \frac{nl_x}{6} \left(3 - \left(\frac{l_x}{l_y} \right)^2 \right) = \frac{10.440 \text{ kN/m}^2 \times 3.6 \text{ m}}{6} \left(3 - \left(\frac{3.6 \text{ m}}{4.5 \text{ m}} \right)^2 \right) = \mathbf{14.783 \text{ kN/m}} \text{ on Beam 8 side of Beam 7.}$$

$$\text{Total } w_{\text{slab}} = 12.403 \text{ kN/m} + 14.783 \text{ kN/m} = \mathbf{27.186 \text{ kN/m}}$$

Step 15: Determine the total load acting on the support beam.

Example:

Refer to Figure 6 and assume that Beam 7 is 1200 mm wide (This depends on the layout as designed in Steps 1 to 4).

Calculate the total loads on the beam.

$$w_{\text{beam}} = 16.650 \text{ kN/m}^2 \text{ (From Step 12)}$$

$$w_{\text{beam}} = 16.650 \text{ kN/m}^2 \times 1.2 \text{ m wide} = \mathbf{19.980 \text{ kN/m}}$$

$$w_{\text{slab}} = 27.186 \text{ kN/m} \text{ (From Step 14)}$$

$$w_{\text{total}} = 19.980 \text{ kN/m} + 27.186 \text{ kN/m} = \mathbf{47.166 \text{ kN/m}}. \text{ Use this load to determine the moments and area of reinforcing steel required to resist bending.}$$

COFFER SLAB DESIGN

Step 16: Determine the maximum mid-span bending moment for the support beam.

There are 4 scenarios to consider if the span of the beams differ by 15% or less:

Scenario 1: Simply supported beam (For example, Beam 6 shown in Figure 3)

$$M_{u,mid} = \frac{wl^2}{8}$$

Scenario 2: Beam continuous one end (For example, Beam 16 shown in Figure 3)

$$M_{u,mid} = \frac{wl^2}{10}$$

Scenario 3: Beam continuous both ends (For example, Beam 7 shown in Figure 3)

$$M_{u,mid} = \frac{wl^2}{12}$$

Scenario 4: Cantilever beam (For example, Beam Q shown in Figure 3)

$$M_{u,mid} = \frac{wl^2}{2}$$

If the span of the beams differ by more than 15%, a rational beam analysis should be done.

For example, Beam 7 (From Figure 6) is continuous both ends, therefore Scenario 3 will be applicable. Calculate the maximum mid-span bending moment for Beam 7:

$w_{total} = 47.166 \text{ kN/m}$ (From Step 15)

Span Length 'L' = 6000 mm = 6.0 m (From Figure 6)

$$\text{Then, } M_u = \frac{47.166 \text{ kN/m} \times (6.0 \text{ m})^2}{12} = \mathbf{141.498 \text{ kN.m.}}$$

Step 17: Determine the moment of resistance of the support beam.

The effective depth for the reinforcing is required to determine the moment of resistance.

The effective depth 'd' is the depth from external face of the compression zone of the beam to the centre of the tension reinforcement as stated in SABS 0100 -1 Ed.2.2, clause 4.3.3.3.

Assume that the redistribution of moments does not to exceed 10%, thus $K = 0.156$ (Refer SABS 0100-1 Ed.2.2, clause 4.3.3.4.1).

To determine the moment of resistance, apply the formula $M_r = Kbd^2f_{cu}$ (Refer SABS 0100-1 Ed.2.2, clause 4.3.3.4.1).

Example:

Beam 7 width 'b' = 1200 mm (From step 15)

$f_{cu} = 30 \text{ MPa}$ (Assumed)

After considering the relationship between the concrete mix design and the amount of reinforcing steel required, the concrete strength is to be determined by the designer.

$K = 0.156$ (Moment distribution < 10%)

$t_{beam} = 425 \text{ mm}$ (From Step 9)

Cover = 30 mm = (From Step 7)

Tension reinforcing diameter = Y16 (Assumed)

Stirrup diameter = R8 (Assumed)

$$d = t_{beam} - \text{cover} - \text{half bar diameter} - \text{diameter}_{\text{stirrup}} = 425 \text{ mm} - 30 \text{ mm} - (16 \div 2) \text{ mm} - 8 \text{ mm} = \mathbf{379 \text{ mm}}$$

$$M_r = Kbd^2f_{cu} = 0.156 \times 1200 \text{ mm} \times (379 \text{ mm})^2 \times 30 \text{ MPa} = 0.156 \times 1.2 \text{ m} \times (0.379 \text{ m})^2 \times 30 \times 10^3 \text{ kN/m}^2 = \mathbf{806.688 \text{ kN.m.}}$$

COFFER SLAB DESIGN

Step 18: Determine the area of tension reinforcing steel required for the support beam at mid-span.

Check if tension reinforcing steel only is required or if both tension and compression reinforcing steel is required for the support beam. This is achieved by checking the 'K' value with the applied bending moment, where:

$$K = \frac{M_{u,mid}}{bd^2f_{cu}} \quad (\text{Refer to SABS 0100-1 Ed.2.2, clause 4.3.3.4.1})$$

If $K > 0.156$, then compression reinforcing steel is required in addition to the tension reinforcing steel.

If compression reinforcing steel is required, the designer should consider increasing the width and/or depth of the support beam as it is not ideal to design for compression reinforcing steel.

If the slab depth is changed, go back to Step 7 and reassess the design.

This Concrete Design Guide does not deal with the design for compression reinforcing steel at mid-span.

Example:

$$M_{u,mid} = 141.498 \text{ kN.m (From Step 16)}$$

$$\text{Beam 7 width 'b'} = 1200 \text{ mm (From Step 15)}$$

$$d = 379 \text{ mm (From Step 17)}$$

$$f_{cu} = 30 \text{ MPa (From Step 17)}$$

$$K = \frac{M_{u,mid}}{bd^2f_{cu}} = \frac{141.498 \text{ kN.m}}{1200 \text{ mm} \times (379 \text{ mm})^2 \times 30 \text{ MPa}} = \frac{141.498 \text{ kN.m}}{1.2 \text{ m} \times (0.379 \text{ m})^2 \times 30 \times 10^3 \text{ kN/m}^2} = 0.027$$

$K < 0.156$, therefore only tension reinforcing steel is required

Determine the lever arm 'z'

The value of 'z' is the lesser of $0.95d$ and $d \times (0.5 + \sqrt{(0.25 - (K \div 0.9))})$ (Refer to SABS 0100-1 Ed.2.2, clause 4.3.3.4.1)

The required area of tension reinforcement at mid-span is determined using the following equation:

$$A_{s,req} = \frac{M_{u,mid}}{0.87f_y z}$$

The area of tension reinforcing steel should not exceed 4% of the gross cross-sectional area of the beam. The minimum percentage of reinforcing steel for a rectangular beam is given in Table 6.

Table 6 - Minimum Percentage Of Reinforcing Steel			
Tension Reinforcing Steel	Definition Of Percentage	Minimum Percentage	
		$f_y = 250 \text{ MPa}$	$f_y = 450 \text{ MPa}$
Rectangular Section	100 A_s/A_c	0.24	0.13

Extract from SABS 0100-1 Ed.2.2, Table 23

Determine the area of reinforcing steel required for Beam 7

$$M_{u,mid} = 141.498 \text{ kN.m (From Step 16)}$$

$$f_y = 450 \text{ MPa for hot-rolled high-yield steel (Refer to SABS 0100-1 Ed.2.2, Table 3)}$$

$$d = 379 \text{ mm (From Step 17)}$$

$$z = \text{lesser of } 0.95 \times 379 \text{ mm} = 360 \text{ mm and } 379 \times (0.5 + \sqrt{(0.25 - (0.018 \div 0.9))}) = 371 \text{ mm}$$

$$t_{beam} = 425 \text{ mm (From Step 9)}$$

$$\text{Beam width 'b'} = 1200 \text{ mm (From Step 15)}$$

$$A_{s,req} = \frac{M_{u,mid}}{0.87f_y z} = \frac{141.498 \text{ kN.m}}{0.87 \times 450 \text{ MPa} \times 360 \text{ mm}} = \frac{141.498 \times 10^3 \text{ kN.mm}}{0.87 \times 450 \times 10^{-3} \text{ kN/mm}^2 \times 360 \text{ mm}} = 1004 \text{ mm}^2$$

$$A_c = b \times t_{beam} = 1200 \text{ mm} \times 425 \text{ mm} = 510.0 \times 10^3 \text{ mm}^2$$

$$A_{s,min} = 0.13 \text{ (From Table 6)} \times (A_c \div 100) = 0.13 \times (510 \times 10^3 \text{ mm}^2 \div 100) = 663 \text{ mm}^2$$

$$A_{s,max} = 4\% \times (b \times t_{beam}) = 0.04 \times (510 \times 10^3 \text{ mm}^2) = 20.4 \times 10^3 \text{ mm}^2$$

$$A_{s,max} > A_{s,req} > A_{s,min} \text{ therefore } A_{s,req} = 1004 \text{ mm}^2.$$

COFFER SLAB DESIGN

Step 19: Select the spacing and type of tension reinforcing steel to be used for mid-span bending.

Determine the diameter and spacing of the tension reinforcing bars.

For this example, assume a spacing of 170 mm (At this stage, the designer must assume the spacing of the reinforcing bars).

The assumed spacing is then used to determine the number of reinforcing bars that will fit across the width of the support beam.

After the number of reinforcing bars is determined, the actual spacing can be calculated.

The required cross-sectional area per reinforcing bar can be determined by dividing the total reinforcing steel area required ($A_{s,req}$) by the number of reinforcing bars provided.

This cross-sectional area must be compared to the values given in Table 7 to determine the reinforcing bar diameter that will meet the minimum cross-sectional area requirements.

Table 7 - Cross-Sectional Area Of Reinforcing Bars Per m Width (mm ²)										
Reinforcing Bar Diameter (mm)	Cross-Sectional Area Per Bar (mm ²)	Spacing Of Reinforcing Bars (mm)								
		50	75	100	125	150	175	200	250	300
8	50	1010	671	503	402	335	287	252	201	168
10	79	1570	1050	785	628	523	449	393	314	262
12	113	2260	1510	1130	905	754	646	566	452	377
16	201	4020	2680	2010	1610	1340	1150	1010	804	670
20	314	6280	4190	3140	2510	2090	1800	1570	1260	1050
25	491	9820	6550	4910	3930	3270	2810	2450	1960	1640
32	804	16100	10700	8040	6430	5360	4600	4020	3220	2680
40	1257	25100	16800	12600	10100	8380	7180	6280	5030	4190

First, check that the assumed and calculated spacing of the reinforcing bars is smaller than the maximum spacing allowed for the specific section by

calculating the service stress $f_s = 0.87f_y \times \frac{y_1 + y_2}{y_3 + y_4} \times \frac{A_{s,req}}{A_{s,prov}} \times \frac{1}{\beta_b}$ (Refer to SABS 0100-1 Ed.2.2, clause 4.3.6.3.1)

Where:

y_1 = self-weight load factor for serviceability limit states = 1.1

y_2 = imposed load factor for serviceability limit states = 1.0

y_3 = self-weight load factor for ultimate limit states = 1.2

y_4 = imposed load factor for ultimate limit states = 1.6

β_b = ratio of resistance moment at mid-span obtained from the redistributed maximum moments diagram to that obtained from the maximum moments diagram before redistribution = 1.0

(Refer to SABS 0100-1 Ed.2.2, clause 4.3.6.3.1; SANS 10160-1, Table 3, and SANS 10160-1, clause 8.3.1.1)

Then, check that the maximum reinforcing bar spacing is the smaller of 300 mm or $47000 \div f_s$ (Refer to SABS 0100-1 Ed.2.2, clause 4.11.8.2.1.4).

Example:

Beam 7 width 'b' = 1200 mm (From step 15)

Spacing of reinforcing bars = 170 mm (Assumed)

f_y = 450 MPa = 450 N/mm² (From Step 18)

$A_{s,req}$ = 1004 mm² (From Step 18)

Number of reinforcing bars = $b - (2 \times \text{cover}) \div \text{spacing} + 1 \text{ bar} = 1200 \text{ mm} - (2 \times 30 \text{ mm}) \div 170 \text{ mm} = 6.7 \text{ bars} + 1 \text{ bar} = 7.7$ rounded up to **8 bars**

Actual spacing = $b - (2 \times \text{cover}) \div (\text{number of bars} - 1 \text{ bar}) = 1200 \text{ mm} - (2 \times 30 \text{ mm}) \div (8 - 1) = 163 \text{ mm}$ rounded down to **160 mm**

Required cross-sectional area per reinforcing bar = $A_{s,req} \div \text{number of reinforcing bars} = 1004 \text{ mm}^2 \div 8 = \mathbf{125.5 \text{ mm}^2}$ per reinforcing bar

From Table 7 it can be seen that 1 No. Y16 reinforcing bar has a cross sectional area of 201 mm² which is greater than the required cross-sectional area of 125.5 mm² per reinforcing bar

The total area $A_{s,prov} = 8 \text{ No.} \times 201 \text{ mm}^2 = \mathbf{1608 \text{ mm}^2}$, which is greater than **1004 mm²**, therefore reinforcing steel is okay

The service stress $f_s = 0.87 (450 \text{ N/mm}^2) \times \frac{1.1 + 1.0}{1.2 + 1.6} \times \frac{1004 \text{ mm}^2}{1608 \text{ mm}^2} \times \frac{1}{1.0} = \mathbf{183 \text{ N/mm}^2}$

COFFER SLAB DESIGN

Check that the maximum reinforcing bar spacing is the smaller of 300 mm or $47000 \div f_s$ (Refer to SABS 0100-1 Ed.2.2, clause 4.11.8.2.1.4)

$$47000 \div f_s = 47000 \div 183 \text{ N/mm}^2 = 257 \text{ mm}$$

The spacing of 160 mm is smaller than the maximum spacing of 257 mm

Therefore, to cater for the bending moment, use 8 No. Y16 reinforcing bars at a spacing of 160 mm.

The designer can choose a larger spacing than the spacing calculated above and re-check the diameter of the reinforcing bars required.

To determine the most economical reinforcing steel, it all depends on the maximum spacing allowed for specific diameters of reinforcing bars.

Step 20: Determining the required number of stirrups.

The number of stirrups is determined based on the number of longitudinal tension reinforcing bars present in the support beam under consideration.

It is good practice to have longitudinal bars in the corner of a stirrup.

Each stirrup has 2 vertical legs which provides a position in each corner for 1 main longitudinal bar.

The number of bars in the support beam is divided by 2 to determine the number of stirrups.

If the total number of main longitudinal tension bars is an uneven number, 1 No. tension bar runs in the middle of the beam without being in the corner of a stirrup.

Example:

Tension reinforcing steel = 8 No. Y16 bars at a spacing of 160 mm (From Step 19)

Beam 7 width 'b' = 1200 mm (From Step 15)

Number of stirrups = $8 \text{ No. Y16} \div 2 \text{ tension bars per stirrup} = 4 \text{ stirrups type A, B, C and D}$ (Refer to Figure 7)

The designer may choose any preferred stirrup configuration provided that the minimum requirement for shear is met

Two typical examples of stirrup arrangements are shown in Figure 7

Example 1 will be the least expensive configuration due to less reinforcing steel being used.

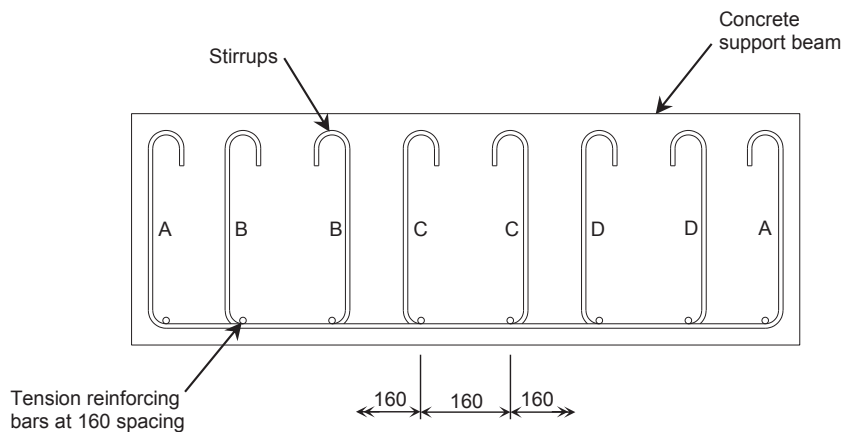

Example 1

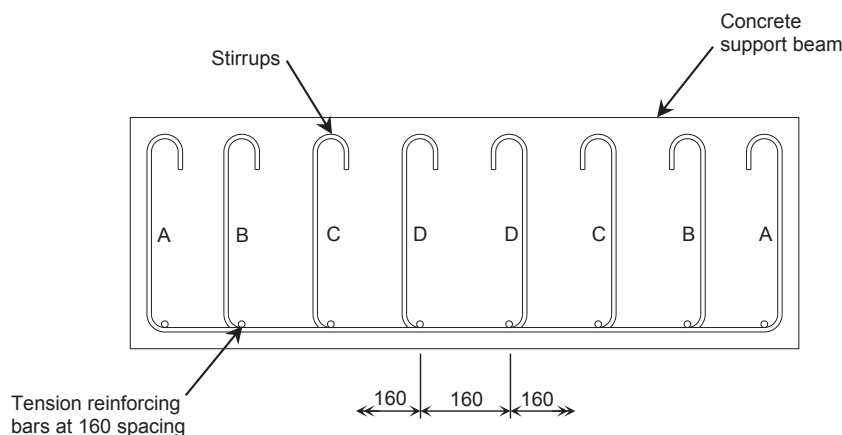

Example 2

Figure 7 – Typical Cross Sections Showing Stirrup Arrangements

COFFER SLAB DESIGN

Step 21: Checking the shear resistance of the support beam.

The design shear force, due to the maximum design loads (for ultimate limit state), must be determined.

To simplify, conservatively assume that the beams are simply supported to determine the reaction forces at each support.

To check the maximum shear strength of a beam, the reaction forces at the internal support must be determined.

If both supports are under continuous beams, both supports must be analysed and the worst case shear force is used in the design calculations.

The design shear stress 'v' at any cross-section of the beam should not exceed a value of the lesser of $\sqrt{f_{cu}}$ or 4.75 MPa. (Refer to SABS 0100-1 Ed.2.2, clause 4.3.4.1.1).

Design shear stress $v = \frac{V}{bd}$ (Refer to SABS 0100-1 Ed.2.2, clause 4.3.4.1.1).

Maximum design shear stress of concrete $v_c = \frac{0.75}{\gamma_m} \left(\frac{f_{cu}}{25} \right)^{1/3} \left(\frac{100A_s}{b_v d} \right)^{1/3} \left(\frac{400}{d} \right)^{1/4}$ (Refer to SABS 0100-1 Ed.2.2, clause 4.3.4.1.2).

In the above equation, it is generally accepted that the value of 0.75 may be increased to 0.79 for design purposes. The value of 0.75 is used throughout in this Concrete Design Guide.

Where $\left(\frac{100A_s}{b_v d} \right)$ should not be taken as greater than 3 (refer SABS 0100-1 Ed.2.2, clause 4.3.4.1.2).

The design shear stress must be less than the maximum design shear stress, if not, either additional shear reinforcement must be added or the cross-section of the beam should be altered.

To determine the required ratio of shear reinforcement to rebar spacing, apply the following equation:

$$\frac{A_{sv}}{s_v} \geq \frac{b(v - v_c)}{0.87f_{yv}}$$

Where:

A_{sv} is the cross-sectional area of the two legs of a stirrup

f_{yv} is the characteristic strength of the stirrup reinforcement ($R8 = 250 \text{ MPa} = 250 \text{ N/mm}^2$) (Refer to SABS 0100-1 Ed.2.2, clause 4.3.4.1.3)

Example:

$w = 47.166 \text{ kN/m}$ (From Step 15)

Span Length 'L' = 6000 mm (From Figure 6)

Beam 7 width 'b' = 1200 mm (From Step 15)

$d = 379 \text{ mm}$ (From Step 17)

$f_{cu} = 30 \text{ MPa} = 30 \text{ N/mm}^2$ (From Step 17)

$A_{s,prov} = 1608 \text{ mm}^2$ (From Step 19)

Partial safety factor for materials for shear strength without shear reinforcement and shear taken by concrete in combination with shear reinforcement $\gamma_m = 1.40$ (Refer to SABS 0100-1 Ed.2.2, clause 3.3.3.2)

$$\text{Then, design shear force } V = \frac{wL}{2} = \frac{47.166 \text{ kN/m} \times 6000 \text{ mm}}{2} = \frac{47.166 \text{ kN/m} \times 6.0 \text{ m}}{2} = 141.498 \text{ kN}$$

Design shear force $V = 2 \times 141.498 \text{ kN} = 282.996 \text{ kN}$, assuming that lengths are the same on either side of the internal support

The designer should do a proper beam analysis to determine the reaction forces on each support, preferably using a specialist software package

$$\text{Design shear stress } v = \frac{V}{bd}$$

$$v = \frac{282.996 \text{ kN}}{1200 \text{ mm} \times 379 \text{ mm}} = \frac{282.996 \times 10^3 \text{ N}}{1200 \text{ mm} \times 379 \text{ mm}} = 0.622 \text{ N/mm}^2 = 0.622 \text{ MPa}$$

Maximum shear stress $v_{max} = \text{smaller of } 0.75\sqrt{30} = 4.108 \text{ MPa and } 4.75 \text{ MPa}$

$v < v_{max}$ therefore okay

$A_{s,prov} = 1608 \text{ mm}^2$ (From Step 19)

$$\frac{100A_s}{b_v d} = \frac{100 \times 1608 \text{ mm}^2}{1200 \text{ mm} \times 379 \text{ mm}} = 0.354 < 3, \text{ therefore okay}$$

COFFER SLAB DESIGN

Partial safety factor for materials for shear strength without shear reinforcement and shear taken by concrete in combination with shear reinforcement $\gamma_m = 1.40$ (Refer to SABS 0100-1 Ed.2.2, clause 3.3.3.2)

$$v_c = \frac{0.75}{1.4} \left(\frac{30 \text{ N/mm}^2}{25} \right)^{1/3} (0.354)^{1/3} \left(\frac{400}{379 \text{ mm}} \right)^{1/4} = 0.408 \text{ N/mm}^2 = \mathbf{0.408 \text{ MPa}}$$

$v > v_c$ therefore additional shear reinforcement must be designed.

To determine the required ratio of shear reinforcement to the reinforcing bar spacing, apply the following equation:

$$\frac{A_{sv}}{s_v} \geq \frac{b(v - v_c)}{0.87f_{yv}}$$

$$\frac{A_{sv}}{s_v} \geq \frac{1200 \text{ mm} (0.622 \text{ N/mm}^2 - 0.408 \text{ N/mm}^2)}{0.87 \times 250 \text{ N/mm}^2} = \mathbf{1.181}$$
 (This ratio will be used in Step 22 to determine the spacing of the stirrups).

Step 22: Determine the spacing of stirrups.

s_v is the spacing of the stirrups along a beam.

The spacing should not exceed 0.75 times the effective depth of the reinforcement.

The initial assumption is made that the spacing of the stirrups is just below 0.75 times the effective depth of the reinforcing steel.

If the assumed spacing of the stirrups is found to be insufficient, the spacing must be reduced accordingly.

If the following equation is true, then the spacing is okay, if not, reduce the spacing:

$$\frac{A_{sv}}{s_v} \geq \frac{b(v - v_c)}{0.87f_{yv}}$$

Where:

A_{sv} = the cross-sectional area of the two legs of a stirrup

f_{yv} = the characteristic shear strength of the link reinforcement (R8 = 250 MPa)
(Refer to SABS 0100-1 Ed.2.2, clause 4.3.4.1.3)

Example:

$d = 379 \text{ mm}$ (From Step 17)

$s_{v,max} = 0.75d = 0.75 \times 379 \text{ mm} = \mathbf{284 \text{ mm}}$

$s_v = 250 \text{ mm}$ (Assumed stirrup spacing)

$s_v < s_{v,max}$ therefore okay

Number of R8 stirrups = 4 No. (From Step 20)

Therefore the number of legs = 4 No. x 2 legs per stirrup = **8 No. legs**

R8 cross-sectional area = 50 mm^2 (Refer to Table 7)

$A_{sv,prov} = 8 \text{ No.} \times 50 \text{ mm}^2 = \mathbf{400 \text{ mm}^2}$

$$\frac{A_{sv}}{s_v} = 1.181 \text{ (From Step 21)}$$

$A_{sv,req} = 1.181 \times 250 \text{ mm spacing} = \mathbf{295.3 \text{ mm}^2}$

$A_{sv,prov} > A_{sv,req}$ therefore okay.

The designer can increase the spacing for a more economical design provided the maximum spacing does not exceed 0.75d.

Provide 4 R8 stirrups @ 250 mm spacing along the full length of the support beam as per Figure 11.

Also provide a clip at the top for each set of stirrups. The clips assist the contractor with the fixing of the reinforcing steel.

COFFER SLAB DESIGN

Step 23: Determine the maximum support bending moment for the beam.

There are 4 scenarios to consider if the span of the beams differ by 15% or less:

Scenario 1:

External support on continuous beam (For example, the column at grid lines 2/A shown in Figure 3)

$$M_{u,\text{sup}} = 0$$

Scenario 2:

1st Internal support on continuous beam (For example, the column at grid lines 2/B shown in Figure 3)

$$M_{u,\text{sup}} = - \frac{wl^2}{9}$$

Scenario 3:

2nd Internal support on continuous beam (For example, the column at grid lines 2/C shown in Figure 3)

$$M_{u,\text{mid}} = - \frac{wl^2}{12}$$

Scenario 4:

Simply supported beam (For example, Beam 6 shown in Figure 3)

$$M_{u,\text{mid}} = 0$$

If the span of the beams differ by more than 15%, a rational beam analysis should be done.

Example:

Assume that Beam 7 is continuous both ends, thus scenario 2 or 3 will be applicable depending on the support being designed

Assume the 1st internal support is being designed, then Scenario 2 is applicable

$w = 47.166 \text{ kN/m}$ (From Step 15)

Span Length 'L' = 6.0 m Assumed (From Step 6)

Calculate the maximum support bending moment for Beam 7:

$$M_{u,\text{sup}} = - \frac{47.166 \text{ kN/m} \times (6.0 \text{ m})^2}{9} = - 188.664 \text{ kN.m.}$$

COFFER SLAB DESIGN

Step 24: Determine the area of tension reinforcing steel required for the beam at the support.

Check if only tension reinforcing steel is required for the support beam or if compression reinforcement is also required.

This is achieved by checking the 'K' value with the applied bending moment, where:

$$K = \frac{M_{u,\text{sup}}}{bd^2f_{cu}} \quad (\text{Refer to SABS 0100-1 Ed.2.2, clause 4.3.3.4.1})$$

If $K > 0.156$, then compression reinforcement is required in addition to the tension reinforcement.

If this is the case, the designer should increase the width of the beam as it is not ideal to design for compression reinforcement.

This Design Guide will not discuss the design for compression reinforcement at mid-span.

Example:

Beam 7 width 'b' = 1200 mm (From Step 15)

$M_{u,\text{sup}} = -188.664$ kN.m (From Step 23)

$d = 379$ mm (From Step 17)

$f_{cu} = 30$ MPa (From Step 17)

$$K = \frac{188.664 \text{ kN.m}}{1200 \text{ mm} \times (379 \text{ mm})^2 \times 30 \text{ MPa}} = \frac{188.664 \text{ kN.m}}{1.2 \text{ m} \times (0.379 \text{ m})^2 \times 30 \times 10^3 \text{ kN/m}^2} = 0.036$$

Thus $K < 0.156$, therefore only tension reinforcement is required

Determine the lever arm 'z'

The value of 'z' is the lesser of $0.95d$ and $d \times (0.5 + \sqrt{(0.25 - (K \div 0.9))})$ (Refer to SABS 0100-1 Ed.2.2, clause 4.3.3.4.1)

The required area of tension reinforcement is determined using the following equation:

$$A_{s,\text{req}} = \frac{M_{u,\text{sup}}}{0.87f_y z}$$

The area of tension reinforcing steel should not exceed 4% of the gross cross-sectional area of the beam.

The minimum percentage of reinforcing steel for a rectangular beam is given in Table 6 (Refer to Step 18).

Example:

$M_{u,\text{sup}} = -188.664$ kN.m (From Step 23)

$f_y = 450$ MPa for hot-rolled high-yield steel (Refer to SABS 0100-1 Ed.2.2, Table 3)

$d = 379$ mm (From Step 17)

$z = \text{lesser of } 0.95 \times 379 \text{ mm} = 360 \text{ mm and } 379 \times (0.5 + \sqrt{(0.25 - (0.024 \div 0.9))}) = 369 \text{ mm}$

$$A_{s,\text{req}} = \frac{188.664 \text{ kN.m}}{0.87 \times 450 \text{ MPa} \times 360 \text{ mm}} = \frac{188.664 \times 10^3 \text{ kN.mm}}{0.87 \times 450 \times 10^{-3} \text{ kN/mm}^2 \times 360 \text{ mm}} = 1339 \text{ mm}^2$$

Beam 7 width 'b' = 1200 mm (From Step 15)

$t_{\text{beam}} = 425$ mm (From Step 9)

$A_c = b \times t_{\text{beam}} = 1200 \text{ mm} \times 425 \text{ mm} = 510.0 \times 10^3 \text{ mm}^2$

$A_{s,\text{min}} = 0.13 \times A_c \div 100 = 0.13 \times 510.0 \times 10^3 \div 100 = 663 \text{ mm}^2$

$A_{s,\text{max}} = 4\% \times (b \times t_{\text{beam}}) = 0.04 \times (1200 \text{ mm} \times 425 \text{ mm}) = 20.4 \times 10^3 \text{ mm}^2$

$A_{s,\text{max}} > A_{s,\text{req}} > A_{s,\text{min}}$ therefore $A_{s,\text{req}} = 1339 \text{ mm}^2$.

COFFER SLAB DESIGN

Step 25: Select the spacing and type of tensile reinforcement to be used for support bending.

The diameter and spacing of the reinforcing bars must now be determined.

The designer can assume the spacing and number of reinforcing bars to be the same as the spacing for the reinforcement at mid-span as determined in Step 19 to simplify the fixing of the reinforcing bars.

The required cross-sectional area of each reinforcing bar ($A_{s,req}$) can be determined by dividing the total required area of reinforcement by the number of reinforcing bars provided.

To meet the minimum cross-sectional area requirements, this cross-sectional area must be compared to the values given in Table 7 to determine the diameter of the reinforcing bar required.

First, check that the assumed and calculated spacing of the reinforcing bars is smaller than the maximum spacing allowed for the specific section by

$$\text{calculating the service stress } f_s = 0.87f_y \times \frac{y_1 + y_2}{y_3 + y_4} \times \frac{A_{s,req}}{A_{s,prov}} \times \frac{1}{\beta_b} \quad (\text{Refer to SABS 0100-1 Ed.2.2, clause 4.3.6.3.1})$$

Where:

y_1 = self-weight load factor for serviceability limit states = 1.1

y_2 = imposed load factor for serviceability limit states = 1.0

y_3 = self-weight load factor for ultimate limit states = 1.2

y_4 = imposed load factor for ultimate limit states = 1.6

β_b = ratio of resistance moment at mid-span obtained from the redistributed maximum moments diagram to that obtained from the maximum moments diagram before redistribution = 1.0
(Refer to SABS 0100-1 Ed.2.2, clause 4.3.6.3.1; SANS 10160-1, Table 3, and SANS 10160-1, clause 8.3.1.1)

Then, check that the maximum reinforcing bar spacing is the smaller of 300 mm or $47000 \div f_s$ (Refer to SABS 0100-1 Ed.2.2, clause 4.11.8.2.1.4).

Example:

Beam 7 width 'b' = 1200 mm (From step 15)

Spacing of reinforcing bars = 160 mm (From Step 19)

f_y = 450 MPa = 450 N/mm² (From Step 18)

$A_{s,req}$ = 1339 mm² (From Step 24)

Number of reinforcing bars = 8 No. Y16 (From Step 19)

Required cross-sectional area per reinforcing bar = $A_{s,req} \div \text{number of reinforcing bars} = 1339 \text{ mm}^2 \div 8 = 167 \text{ mm}^2$ per reinforcing bar

From Table 7, a Y16 reinforcing bar has a larger cross-sectional area (201 mm²) than the required reinforcing bar area of 167 mm²

For a more economical design, instead of using 8 No. Y16, use 6 No. Y16 and 2 No. Y12 reinforcing bars.

The total area $A_{s,prov} = 6 \text{ No.} \times 201 \text{ mm}^2 + 2 \text{ No.} \times 113 \text{ mm}^2 = 1432 \text{ mm}^2$, which is greater than 1339 mm², therefore reinforcing steel is okay

$$\text{The service stress } f_s = 0.87 (450 \text{ N/mm}^2) \times \frac{1.1 + 1.0}{1.2 + 1.6} \times \frac{1339 \text{ mm}^2}{1432 \text{ mm}^2} \times \frac{1}{1.0} = 275 \text{ N/mm}^2$$

Check that the maximum reinforcing bar spacing is the smaller of 300 mm or $47000 \div f_s$

$$47000 \div f_s = 47000 \div 275 \text{ N/mm}^2 = 171 \text{ mm}$$

The spacing of 160 mm is smaller than the maximum spacing of 175 mm

Therefore, to cater for the moment, use 6 No. Y16 and 2 No. Y12 reinforcing bars at a spacing of 160 mm for Beam 7.

The designer can choose a larger spacing than the spacing calculated above and re-check the diameter of the reinforcing bars required.

To determine the most economical reinforcing steel, it all depends on the maximum spacing allowed for specific diameters of reinforcing bars.

COFFER SLAB DESIGN

Step 26: Check the deflections based on the basic allowable span.

To prevent damage to finishes and partitions for beams with spans up to 10 m, the deflection must be limited to the span divided by 250. The basic span/effective depth ratios are given in Table 4.

Serviceability Limit State Load = 1.1DL + 1.0LL (Refer to SANS 10160-1, clause 8.3.1.1).

The basic span/effective depth ratio value obtained from Table 4 must be modified with a modification factor that takes into account the amount of tension reinforcement and the associated stresses when the allowable span/effective depth ratio is calculated.

The modification factor is derived from the following equation:

$$\text{Modification factor} = 0.55 + \frac{477 - f_s}{120 \left(0.9 + \frac{M_u}{bd^2} \right)} \leq 2.0 \quad (\text{Refer to SABS 0100-1 Ed.2.2, clause 4.3.6.3.1})$$

The allowable span/effective depth ratio will then be the basic span/effective depth ratio multiplied by the calculated modification factor. The actual span/effective depth ratio can now be calculated using the beam layout shown in Figure 8.

If the actual span/effective depth ratio is bigger than the allowable span/effective depth ratio, the beam fails due to deflection.

Example:

The end span condition for Beam 7 = continuous both ends (Refer to Figure 8)

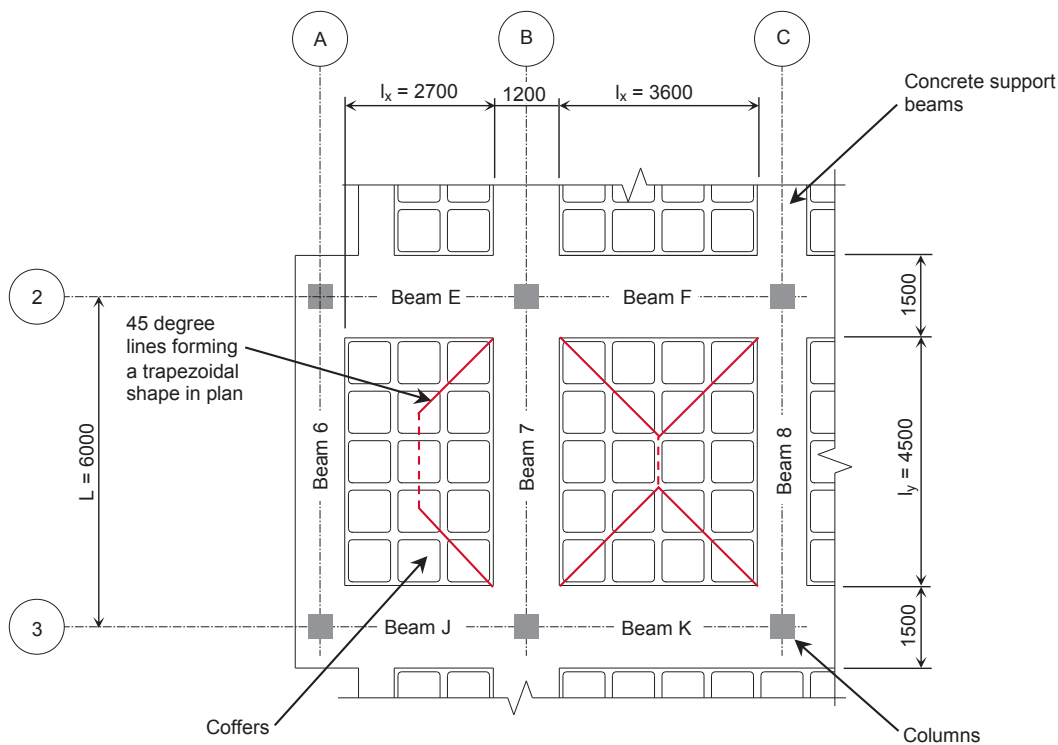

Figure 8 – Typical Plan View Of Coffers And Support Beam Layout (Extract from Figure 3)

Determine the serviceability load:

Where:

Beam 7 width 'b' = 1200 mm (From Step 15)

$DL_{\text{beam}} = 11.875 \text{ kN/m}^2 \times 1.2 \text{ m wide} = 14.250 \text{ kN/m}$ (From Step 10)

$LL_{\text{beam}} = 1.5 \text{ kN/m}^2 \times 1.2 \text{ m wide} = 1.800 \text{ kN/m}$ (From Step 12)

Beam load = $(1.1 \times 14.250 \text{ kN/m}) + (1.0 \times 1.800 \text{ kN/m}) = 17.475 \text{ kN/m}$

$DL_{\text{slab}} = 6.700 \text{ kN/m}^2$ (From Step 12)

$LL_{\text{slab}} = 1.5 \text{ kN/m}^2$ (From Step 12)

$$\text{Slab Load (Trapezoidal shape in plan)} = \frac{nl_x}{6} \left(3 - \left(\frac{l_x}{l_y} \right)^2 \right) = \frac{((1.1 \times 6.700 \text{ kN/m}^2) + (1.0 \times 1.5 \text{ kN/m}^2)) \times 2.7 \text{ m}}{6} \left(3 - \left(\frac{2.7 \text{ m}}{4.5 \text{ m}} \right)^2 \right) = 10.538 \text{ kN/m}$$

$$\text{Slab Load (Trapezoidal shape in plan)} = \frac{nl_x}{6} \left(3 - \left(\frac{l_x}{l_y} \right)^2 \right) = \frac{((1.1 \times 6.700 \text{ kN/m}^2) + (1.0 \times 1.5 \text{ kN/m}^2)) \times 3.6 \text{ m}}{6} \left(3 - \left(\frac{3.6 \text{ m}}{4.5 \text{ m}} \right)^2 \right) = 12.560 \text{ kN/m}$$

Total serviceability load $w = 17.475 \text{ kN/m} + 10.538 \text{ kN/m} + 12.560 \text{ kN/m} = 40.573 \text{ kN/m}$

COFFER AND TROUGH SLAB DESIGN

COFFER SLAB DESIGN

Calculate the service stress:

Where:

$$A_{s,req} = 1004 \text{ mm}^2 \text{ (From Step 18)}$$

$$A_{s,prov} = 1608 \text{ mm}^2 \text{ (From Step 19)}$$

Total ultimate load $w_{total} = 34.763 \text{ kN/m}$ (From Step 15)

$$\text{Service stress} = 0.87 (450 \text{ MPa}) \times \frac{40.573 \text{ kN/m}}{47.166 \text{ kN/m}} \times \frac{1004 \text{ mm}^2}{1608 \text{ mm}^2} \times \frac{1}{1} = 0.87 (450 \text{ N/mm}^2) \times \frac{40.573 \times 10^6 \text{ N/mm}}{47.166 \times 10^6 \text{ N/mm}} \times \frac{1004 \text{ mm}^2}{1608 \text{ mm}^2} \times \frac{1}{1} = 210 \text{ N/mm}^2$$

Calculate the modification factor:

Where:

$$M_u = 141.498 \text{ kN.m} = 141.498 \times 10^6 \text{ N.mm} \text{ (From Step 16)}$$

$$d = 379 \text{ mm} \text{ (From Step 17)}$$

$$\text{Modification factor} = 0.55 + \frac{477 - f_s}{120 \left(0.9 + \frac{M_u}{bd^2} \right)} = 0.55 + \frac{477 \text{ N/mm}^2 - 210 \text{ N/mm}^2}{120 \left(0.9 \text{ N/mm}^2 + \frac{141.498 \times 10^6 \text{ N.mm}}{1200 \text{ mm} \times (379 \text{ mm})^2} \right)} = 1.843$$

The modification factor of 1.843 is smaller than 2.0, therefore take the modification factor as 1.843

Allowable span/effective depth ratio = (Modification factor) x (Basic span/effective depth ratio)

Where:

$$\text{Basic span/effective depth ratio} = 28 \text{ (From Table 4)}$$

$$\text{(Modification factor) x (Basic span/effective depth ratio)} = 1.843 \times 28 = 51.6$$

$$\text{Span Length 'L'} = 6000 \text{ mm} \text{ (From Step 6)}$$

$$\text{Actual span} \div \text{effective depth} = 6000 \text{ mm} \div 379 \text{ mm} = 15.8 < 51.6 \text{ therefore the beam is okay.}$$

COFFER SLAB DESIGN

Step 27: Calculate the actual long-term deflections of the support beams.

The designer needs to determine the Moment of Inertia for the cross-sectional area of the concrete beam.

This is done by taking the width and the thickness of the beam into consideration using the following formula:

$$I_x = \frac{bh^3}{12}$$

The short-term modulus of elasticity for the specified strength of the concrete can be determined from Table 8.

For long term deflections, a conservative assumption is that the modulus of elasticity is only half the value given in Table 8.

Table 8 - Modulus Of Elasticity Of Concrete	
Cube Strength Of Concrete At The Appropriate Age Or Under Construction (MPa)	Modulus Of Elasticity Of Concrete E _c (GPa)
20	25
25	26
30	28
40	31
50	34
60	36

Refer to SABS 0100-1 Ed.2.2, Table 1

Long term deflections can then be determined using one of the following equations:

Truly simply supported beam $\delta = \frac{5wl^4}{384E_c I_x}$ (For example, Beam 6 shown in Figure 3)

Beam with one end continuous $\delta = 0.0099 \frac{wl^4}{E_c I_x}$ (For example, Beam 16 shown in Figure 3)

Beam with both ends continuous $\delta = 0.0068 \frac{wl^4}{E_c I_x}$ (For example, Beam 7 shown in Figure 3)

The recommended limit to prevent damage to finishes and partitions is the span divided by 250 (Refer to SABS 0100-1 Ed.2.2, clause 4.3.6.2.1).

If the calculated actual long-term deflection is less that the recommended limit, then the beam is okay.

Example:

Beam 7 width 'b' = 1200 mm (From Step 15)

h = t_{beam} = 425 mm (From Step 9)

w = 40.573 kN/m (From Step 26)

Span Length 'L' = 6000 mm (From Step 6)

$$I_x = \frac{bh^3}{12} = \frac{1200 \text{ mm} \times (425 \text{ mm})^3}{12} = 7.677 \times 10^9 \text{ mm}^4$$

f_{cu} = 30 MPa (From Step 17)

E_c = 28 GPa (From Table 8), therefore E_c = 28 GPa ÷ 2 = 14 GPa

End span condition = Continuous both ends

Actual long-term deflection:

$$\delta = 0.0068 = \frac{wl^4}{E_c I_x} = \frac{0.0068 \times (40.573 \text{ kN/m}) \times (6000 \text{ mm})^4}{(14 \times 10^3 \text{ GPa}) \times (7.677 \times 10^9 \text{ mm}^4)} = \frac{0.0068 \times (40.573 \times 10^3 \text{ kN/mm}) \times (6000 \text{ mm})^4}{(14 \times 10^6 \text{ kN/mm}^2) \times (7.677 \times 10^9 \text{ mm}^4)} = 3.3 \text{ mm}$$

$$\text{Recommended limit} = \frac{\text{Span}}{250} = \frac{6000 \text{ mm}}{250} = 24.0 \text{ mm}$$

3.3 mm < 24.0 mm therefore the deflection of the slab is okay.

If the long-term deflection exceeds the recommended limit, the excessive deflection may be offset by specifying a pre-camber for the beam.

COFFER SLAB DESIGN

Step 28: Steel detailing of mid-span tension reinforcing steel for the support beams.

The following rules must be taken into consideration when detailing mid-span tension reinforcing steel:

Rule 1. Span:

- 1.1 The assumption is made that the Span Length 'L' equals the lesser of the clear span plus the effective depth and the distance from centre line to centre line of the supports.

Rule 2. Simply supported beams: (For example, Beam 6 shown in Figure 3)

- 2.1 At least 50% of the tension reinforcing steel at mid-span shall extend to the supports and have an effective anchorage of 12 bar diameters beyond the centre line of the support.
- 2.2 No hook or bend shall begin before the centre line.
- 2.3 At least 25% of the reinforcing steel shall extend to within 0.08L of the support centre line and the rest shall extend to within 0.15L of the support centre line.

Rule 3. Cantilever beams: (For example, Beam Q shown in Figure 3)

- 3.1 At least 50% of the tension reinforcing steel shall extend to the end of the cantilever (and be turned down for bond if necessary) and the remaining reinforcing steel shall extend to a distance (from the face of the support) of the greater of 0.5L and 45 bar diameters.

Rule 4. Continuous beams: (For example, Beam 7 shown in Figure 3)

- 4.1 At least 30% of the bottom reinforcing steel in tension at mid-span shall extend to the supports.
- 4.2 Half the remainder shall extend to within 0.2L of the centre line of internal supports.
- 4.3 The remaining 35% shall extend to within 0.1L of the centre line of supports.
- 4.4 At a non-continuous end, 50% of the tension reinforcing steel shall extend to the supports and terminate in an effective anchorage as in Rule 2 above and the remainder must extend to within 0.05L of the centre line of the support.

(Refer to SABS 0144 Ed.3, clauses 7.10.4 and 7.10.5).

It is recommended that the above rules are used as a guideline only.

The reinforcing configuration, type, size, and amount or reinforcing steel detailed, will vary between designers and detailers.

It is recommended that reinforcing steel is detailed using the minimum amount of bars and lengths of bars.

Using many different bar lengths and configurations will increase the risk of fixing errors and fixing time on site.

Example:

Apply Rule 4 to Beam 7 (Continuous beam):

Number of reinforcing bars = 8 No. (From Step 19)

Assumed support width = 400 mm (Refer to Figure 9)

$d = 379$ mm (From Step 17).

Rule 4.1:

30% of the 8 No. Y16 reinforcing bars = **2.4** bars

To balance the configuration of the reinforcing bars across the width of the beam, increase the number of reinforcing bars from 2.4 to 4 bars

These 4 reinforcing bars must extend to the face of the supports.

Rule 4.2:

The remainder of the reinforcing bars = (8 bars – 4 bars) = **4** No. bars

Half the remainder of the reinforcing bars = **2** bars

Therefore, 2 No. reinforcing bars, shall extend to within 0.2L of the centre line of internal supports, where:

Centre line to centre line of supports = 6000 mm (Refer to Figure 9)

However, Span Length 'L' = the lesser of:

$(6000 \text{ mm} + 379 \text{ mm}) = 6379 \text{ mm}$ and $(6000 \text{ mm} + 500 \text{ mm} + 500 \text{ mm}) = 7000 \text{ mm}$ **Figure 9 – Typical Plan View Of Coffers And Beam Layout (Extract From Figure 3)**

These reinforcing bars must extend to within $(0.2 \times 6379 \text{ mm}) = 1276 \text{ mm}$ from the centre line of the supports.

Rule 4.3:

The remaining 2 No. reinforcing bars shall extend to within 0.1L of the centre line of supports

Centre line to centre line of supports = 6000 mm (Refer to Figure 9)

However, Span Length 'L' = the lesser of:

$(6000 \text{ mm} + 379 \text{ mm}) = 6379 \text{ mm}$ and $(6000 \text{ mm} + 500 \text{ mm} + 500 \text{ mm}) = 7000 \text{ mm}$

These reinforcing bars must extend to within $(0.1 \times 6379 \text{ mm}) = 638 \text{ mm}$ from the centre line of the supports.

Note:

Although Rules 4.2 and 4.3 are generally applicable, due to the stirrup configuration, all 8 No. reinforcing bars should at least extend all the way up to the inside face of the supports so that the bottom corners of the stirrups can be secured in position.

It is further recommended that at least 50% of the reinforcing bars extend at least 12 bar diameters beyond the centre line of the supports as shown in Figures 10, 11 and 12.

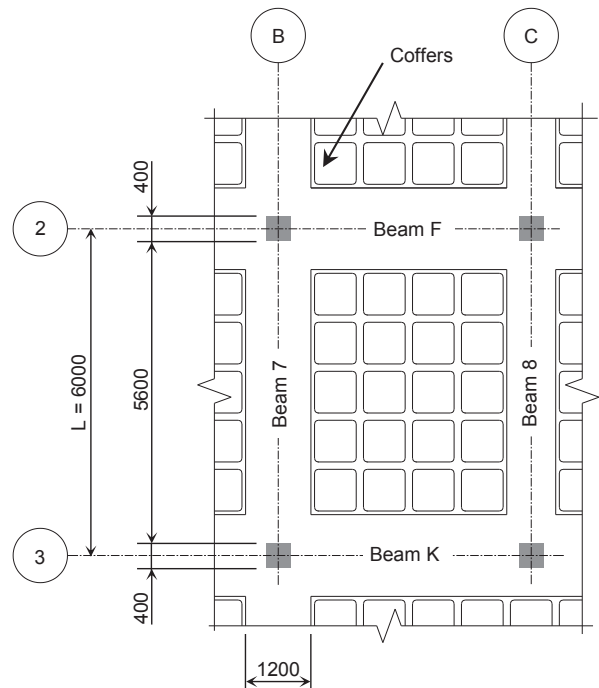

COFFER SLAB DESIGN

Figure 10 shows the bottom tension reinforcement for Beam 7.

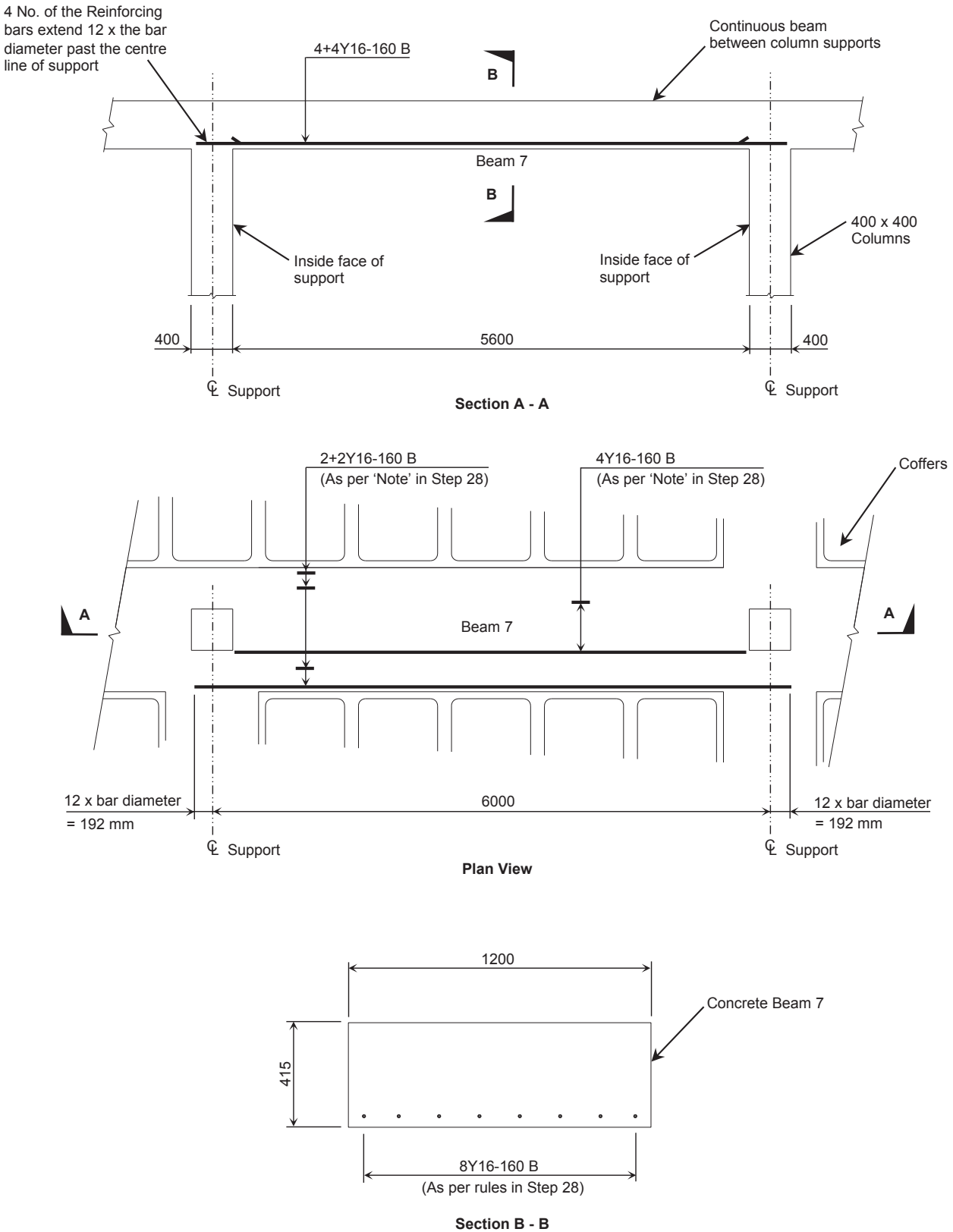

Figure 10 – Bottom Tension Reinforcement For Beam 7

COFFER AND TROUGH SLAB DESIGN

COFFER SLAB DESIGN

Step 29: Steel detailing of the stirrups for the support beams.

The designer may increase the spacing to achieve a more economical design, provided the spacing is below the maximum spacing of 0.75d.

Provide R8 stirrups type A, B, C and D at a 250 mm spacing (From Step 22), along the full length of Beam 7, as shown in Figure 11.

Also provided an additional R8 reinforcing bar (Clip) at the top of each set of stirrups. These bars facilitate the easy fixing of the reinforcement steel.

In addition to the bottom tension reinforcement, Figure 11 shows the reinforcing stirrups for Beam 7.

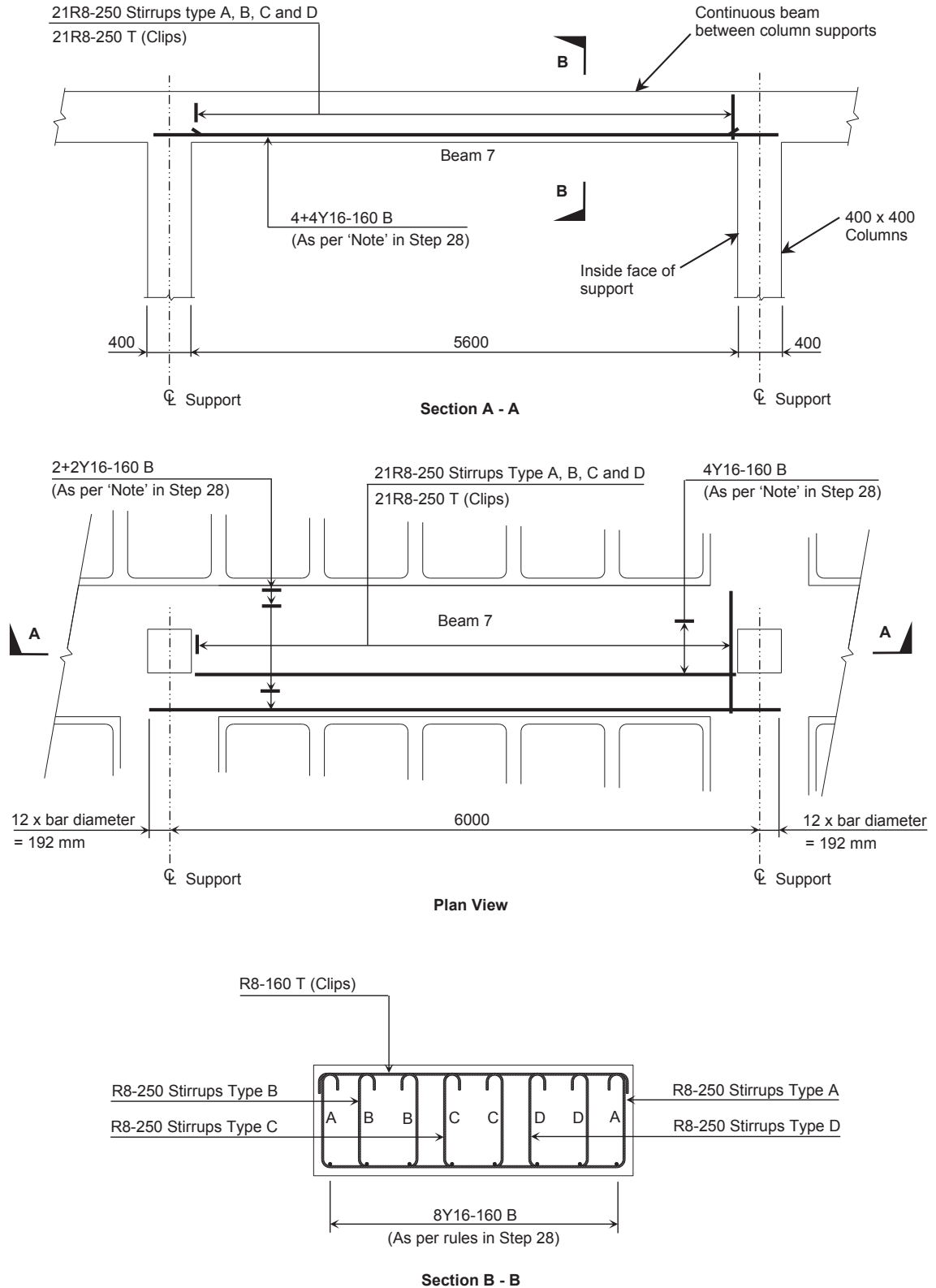

Figure 11 – Bottom Reinforcement And Stirrups For Beam 7

COFFER SLAB DESIGN

Step 30: Steel detailing of support beam tension reinforcing steel and nominal top reinforcing steel at mid-span.

The following rules must be taken into consideration when detailing mid-span tension reinforcing steel for the support beams of a Coffer slab:

Rule 1. Span:

- 1.1 The assumption is made that the Span Length 'L' equals the lesser of the clear span plus the effective depth, and the distance from centre line to centre line of the supports.

Rule 2. Simply supported beams: (For example, Beam 6 shown in Figure 3)

- 2.1 No tension reinforcement is required in the top of the beam at the support.

Rule 3. Cantilever beams: (For example, Beam Q shown in Figure 3)

- 3.1 At least 50% of the tension reinforcing steel shall extend to the end of the cantilever (and be turned down for bond if necessary) and the remaining reinforcing steel shall extend to a distance (from the face of the support) of the greater of 0.5L and 45 bar diameters.

Rule 4. Continuous beams: (For example, Beam 7 shown in Figure 3)

- 4.1 At least 20% of the top reinforcement in tension over the supports of a continuous beam should be made effectively continuous through the spans.
- 4.2 Of the remainder, half should extend to a point at least 0.25L from the face of the support, and the other half to a point at least 0.15L from the face of the support, but no bar should stop at a point less than 45 bar diameters from the face of the support.

(Refer to SABS 0144 Ed.3, clauses 7.10.4 and 7.10.5).

It is recommended that the above rules are used as a guideline only.

The reinforcing configuration, type, size, and amount or reinforcing steel detailed, will vary between designers and detailers.

It is recommended that reinforcing steel is detailed using the minimum amount of bars and lengths of bars.

Using many different bar lengths and configurations will increase the risk of fixing errors and fixing time on site.

Example:

Apply **Rule 4** to Beam 7 (Continuous beam):

Beam 7 width 'b' = 1200 mm (From Step 15)

Tension reinforcement = 6Y16 and 2Y12 reinforcing bars, each at a spacing of 160 mm (From Step 19)

Clear span = 5600 mm (From Figure 9)

Supports = 400 mm (Assumed)

d = 379 mm (From Step 17)

Span length 'L' = lesser of (5600 mm + 379 mm) = **5979** mm and (5600 mm + 200 mm + 200 mm) = **6000** mm.

Rule 4.1:

20% of the 1432 mm² reinforcing bars = 286 mm².

2 No. Y16 reinforcing bars = 402 mm².

These 2 No. Y16 top reinforcing bars must be continuous through the spans.

Rule 4.2:

The remainder of the reinforcing bars = (8 bars – 2 bars) = **6** No. bars.

These 6 No. bars make up the 80% balance of the top reinforcing bars.

In this example, Y16 and Y12 reinforcing bars are being used for the top reinforcing steel.

To prevent an unbalanced configuration of the top reinforcing bars over the support, allow the remaining 6 No. reinforcing bars to extend past the face of the support by the larger of 0.25L or 45d from the face of the support.

(0.25 x 5979 mm) = **1495** mm and (45 x 16 mm) = **720** mm.

Therefore, extend the remaining 6 No. top reinforcing bars 1495 mm (**1500** mm rounded up) past the face of the support.

Note:

To assist with the fixing of the reinforcing bars, it may be prudent to have the same number of top and bottom reinforcing bars.

The 6 No. remaining top reinforcing bars may be made continuous, through the length of the support beam, using a reduced reinforcing bar diameter.

The designer can use any reduced reinforcing bar diameter because the minimum required area of steel is already in place.

In this case, it would be the most economical to use 2 No. Y16 and 6 No. Y12 top reinforcing bars over the mid-span of Beam 7.

COFFER AND TROUGH SLAB DESIGN

COFFER SLAB DESIGN

In addition to the bottom tension reinforcement and stirrups, Figure 12 shows the top reinforcing bars for Beam 7.

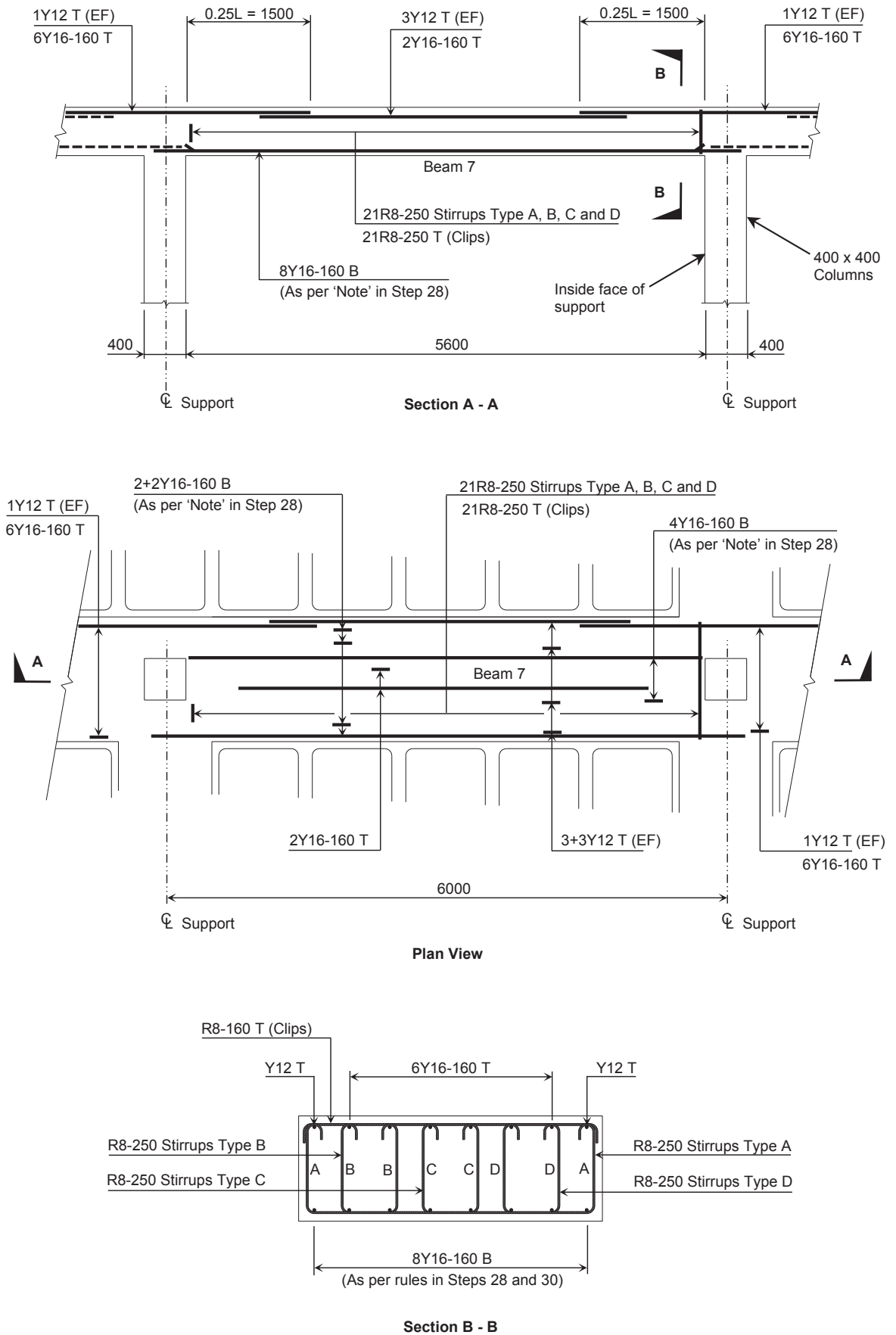

Figure 12 – Top And Bottom Reinforcement And Stirrups For Beam 7

COFFER SLAB DESIGN

PART 3 – Coffer slab design – ribs and structural topping (Steps 31 to 50)

Step 31: Identify and name the Coffer portions between the support beams.

All the support beams should be designed as per Steps 1 to 30, before starting the design of the Coffer portions of the slab.

Identify all the Coffer portions between the support beams, for example C1, C2, C3, etc. as shown in Figure 13.

The identification of each Coffer portion will be used as a cross reference during the design phase and later when scheduling the reinforcing steel.

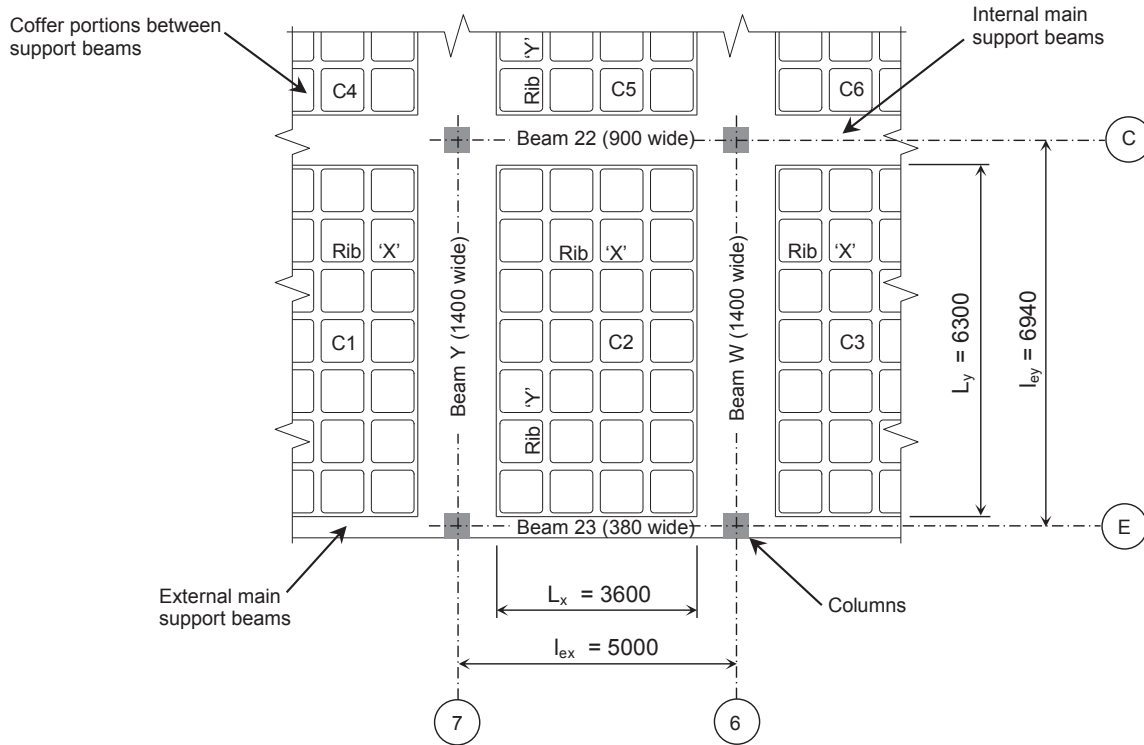

Figure 13 – Typical Beam And Coffers Layout Showing Various Coffer Portions Between Support Beams (Extract From Figure 3)

Step 32: Select a Coffer portion and identify specific details from the drawing.

Select a Coffer portion, for example portion C2 in Figure 13 and establish the relative Coffer configuration, width of the support beams and support end conditions.

Example:

Ribs 'X': (Ribs in the short direction)

Length of Ribs 'L_x' = 3600 mm

For this example, Beam Y = 1400 mm wide and supports the ends of each Rib 'X' on either side of the beam, therefore these Ribs are continuous over this support beam

For this example, Beam W = 1400 mm wide and supports the ends of each Rib 'X' on either side of the beam, therefore these Ribs are continuous over this support beam

The effective length $l_{ex} = 3600 \text{ mm} + ((1400 \text{ mm} + 1400 \text{ mm}) \div 2) = 5000 \text{ mm}$

Ribs 'Y': (Ribs in the long direction)

Length of Ribs 'L_y' = 6300 mm

For this example, Beam 22 = 900 mm wide and supports the ends of each Rib 'Y' on either side of the beam, therefore these Ribs are continuous over this support beam

For this example, Beam 23 = 380 mm wide and supports the ends of each Rib 'Y' on one side of the beam, therefore these Ribs are discontinuous over this support beam

The effective length $l_{ey} = 6300 \text{ mm} + ((900 \text{ mm} + 380 \text{ mm}) \div 2) = 6940 \text{ mm}$

The above example shows that Rib 'X' is continuous in both directions whereas Rib 'Y' is continuous in one direction only.

COFFER AND TROUGH SLAB DESIGN

COFFER SLAB DESIGN

Step 33: Determine the minimum structural topping thickness due to deflection, for the selected Coffer height.
The total slab thickness will remain the same as previously determined in Step 8.

Refer to Table 9 to determine the minimum structural topping thickness required for each Coffer size when considering deflection.

Table 9 - Minimum Structural Topping Thickness For Coffers Due To Deflection						
Coffer Size (mm)	Clear Distance Between Ribs At Top (mm)	Clear Distance (mm)	Rib Width At Top 'b _{rib.top} ' (mm)	Average Rib Width 'b _{rib.ave} ' (mm)	Rib Width At Bottom 'b _{rib.bot} ' (mm)	Minimum Structural Topping (mm)
525	562	772	338	233	128	56
425	602	772	298	213	128	60
325	642	772	258	193	128	64
225	682	772	218	173	128	68

Figure 14 gives the concrete dimensions for the different Coffer sizes.

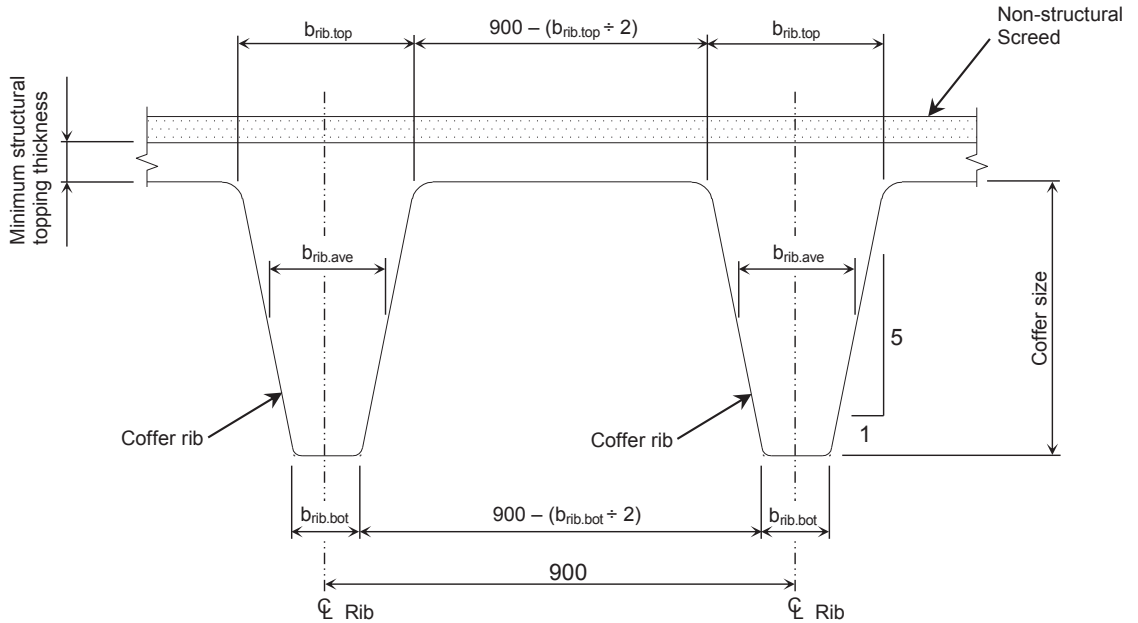

Figure 14 – Typical Coffers Section

Example:

Coffer height + structural topping = 325 mm Coffer + 100 mm structural topping = **425 mm** (From Step 9).

Determine the minimum structural topping thickness:

The minimum structural topping thickness for a 325 Coffer = **64 mm** (From Table 9).

Step 34: Determine the self-weight of the Coffer slab and imposed loads on the Coffer slab.

The self-weight and imposed loads acting on the Coffer slab will be the same as determined in Steps 11 and 12.

Example:

$$w_{\text{slab}} = (1.2 \times 5.425 \text{ kN/m}^2) + (1.6 \times 1.5 \text{ kN/m}^2) = \mathbf{8.910 \text{ kN/m}^2}$$
 (From Step 12).

COFFER SLAB DESIGN

Step 35: Determine the span end conditions and maximum moments of the Coffer slab.

Every slab will have ribs in both directions as shown in Figure 13 and Step 32.

Rib 'X' is the rib spanning in the short direction and Rib 'Y' is the rib spanning in the long direction.

The end conditions and supporting conditions have a major impact on the moment calculation for every rib.

There are 3 scenarios to be considered before calculating the maximum moment for each rib.

Scenario 1:

Where the corners are prevented from lifting and provision for torsion is made, the maximum moment for each span can be calculated using the following equations:

$$M_{sx} = \beta_{sx} n l_x^2$$

$$M_{sy} = \beta_{sy} n l_x^2$$

Where $n = 1.2DL + 1.6LL$ calculated in Step 34 and the factors β_{sx} and β_{sy} are determined using interpolation of factors from Table 10.

The designer must identify which case is applicable due to the slab conditions as described in the 'Type Of Coffer Portions And Moment Considered' column in Table 10.

(Refer to SABS 0100-1 Ed.2.2, clause 4.4.4.2).

Note:

The length of the shorter span must be used in both equations.

Table 10 - Bending Moment Coefficients For Rectangular Coffer Portions Supported On Four Sides With Provision For Torsional Reinforcement At The Corners

Case	Type Of Coffer Portion And Moments Considered	Short-span Coefficients β_{sx}								Long-span Coefficients β_{sy} For All Values Of l_y/l_x
		Values Of l_y/l_x								
		1.0	1.1	1.2	1.3	1.4	1.5	1.75	2.0	
1	Interior Coffer portion									
	Negative moment at continuous edge	0.031	0.037	0.042	0.046	0.050	0.053	0.059	0.063	0.032
	Positive moment at mid-span	0.024	0.028	0.032	0.036	0.039	0.041	0.045	0.049	0.024
2	One short edge discontinuous									
	Negative moment at continuous edge	0.039	0.044	0.048	0.052	0.055	0.058	0.063	0.067	0.037
	Positive moment at mid-span	0.029	0.033	0.036	0.039	0.041	0.043	0.047	0.050	0.028
3	One long edge discontinuous									
	Negative moment at continuous edge	0.039	0.049	0.056	0.062	0.068	0.073	0.082	0.089	0.037
	Positive moment at mid-span	0.030	0.036	0.042	0.047	0.051	0.055	0.062	0.067	0.028
4	Two adjacent edges discontinuous									
	Negative moment at continuous edge	0.047	0.056	0.063	0.069	0.074	0.078	0.087	0.092	0.045
	Positive moment at mid-span	0.036	0.042	0.047	0.051	0.055	0.059	0.065	0.070	0.034
5	Two short edges discontinuous									
	Negative moment at continuous edge	0.046	0.050	0.054	0.057	0.06	0.062	0.067	0.070	-
	Positive moment at mid-span	0.034	0.038	0.040	0.043	0.045	0.045	0.047	0.053	0.034
6	Two long edges discontinuous									
	Negative moment at continuous edge	-	-	-	-	-	-	-	-	0.045
	Positive moment at mid-span	0.034	0.046	0.056	0.065	0.072	0.078	0.091	0.100	0.034
7	Three edges discontinuous (one long edge continuous)									
	Negative moment at continuous edge	0.057	0.065	0.071	0.076	0.080	0.084	0.092	0.098	-
	Positive moment at mid-span	0.043	0.048	0.053	0.057	0.060	0.063	0.069	0.074	0.044
8	Three edges discontinuous (one short edge continuous)									
	Negative moment at continuous edge	-	-	-	-	-	-	-	-	0.058
	Positive moment at mid-span	0.042	0.054	0.063	0.071	0.078	0.084	0.096	0.105	0.044
9	Four edge discontinuous									
	Positive moment at mid-span	0.055	0.065	0.074	0.081	0.087	0.092	0.103	0.111	0.056

COFFER SLAB DESIGN

Torsional reinforcement at any corner, where the slab is simply supported on both edges meeting at that corner, should comprise of 4 layers with an area of reinforcement in each of these layers equal to three quarters of the area required for the maximum mid-span moment in the slab.

Torsional reinforcement at any corner contained by edges, over only one of which is where the slab is continuous, the reinforcement should be half of the reinforcement described in the paragraph above.

Scenario 2:

Where the rectangular slab is simply supported on four sides and does not have adequate provision to resist torsion at the corners.

The maximum moment to prevent the corners from lifting can be determined using the following equations:

$$M_{sx} = \alpha_{sx} n l_{ex}^2$$

$$M_{sy} = \alpha_{sy} n l_{ex}^2$$

Where:

$n = 1.2DL + 1.6LL$ calculated in Step 34 and the factors α_{sx} and α_{sy} are determined using interpolation of factors from Table 11. (Refer to SABS 0100-1 Ed.2.2, clause 4.4.4.1).

l_y / l_x	α_{sx}	α_{sy}
1.0	0.045	0.045
1.1	0.061	0.038
1.2	0.071	0.031
1.3	0.08	0.027
1.4	0.087	0.023
1.5	0.092	0.020
1.6	0.097	0.017
1.7	0.100	0.015
1.8	0.102	0.016
1.9	0.103	0.016
2.0	0.104	0.016
2.5	0.108	0.016
3.0	0.111	0.017

Scenario 3:

A one way spanning slab is when $l_y \geq 3l_x$ and the following is used to determine the maximum moments in the short span direction for the ribs.

There are 3 sub-scenarios to consider:

Scenario 3.1: Simply supported rib

$$M_u = \frac{w l_x^2}{8}$$

Scenario 3.2: Rib continuous one end

$$M_u = \frac{W l_x^2}{10}$$

Scenario 3.3: Rib continuous both ends

$$M_u = \frac{w l_x^2}{12}$$

Example:

In this example, load bearing walls are constructed on top of the slab around the perimeter of the slab.

Extract from SABS 0100-1 Ed.2.2, Table 14

Therefore the slab corners are prevented from lifting and provision for torsion has to be made.

The following maximum moment calculations are applicable:

$$M_{sx} = \beta_{sx} n l_x^2$$

$$M_{sy} = \beta_{sy} n l_x^2$$

The slab layout in Figure 13, Step 31, has one short edge that is discontinuous and is therefore select Case 2 from Table 10.

Refer to the extract from Table 10 below, showing Case 2.

Case	Type Of Coffers Portion And Moments Considered	Short-span Coefficients β_{sx}								Long-span Coefficients β_{sy} For All Values Of l_y / l_x
		Values Of l_y / l_x								
		1.0	1.1	1.2	1.3	1.4	1.5	1.75	2.0	
2	One short edge discontinuous									
	Negative moment at continuous edge	0.039	0.044	0.048	0.052	0.055	0.058	0.063	0.067	0.037
	Positive moment at mid-span	0.029	0.033	0.036	0.039	0.041	0.043	0.047	0.05	0.028

COFFER SLAB DESIGN

$l_{ex} = 5000$ mm (From Step 32)

$l_{ey} = 6940$ mm (From Step 32)

$l_{ey} / l_{ex} = 1.39$

β_{sx} and β_{sy} is determined from Table 10

If the value is not exactly the same as the given value of l_y / l_x in Table 10, the designer must interpolate to determine the actual values of β_{sx} and β_{sy}

$\beta_{sx} = 0.055$ (Negative moment at continuous edge)

$\beta_{sx} = 0.041$ (Positive moment at mid-span)

$\beta_{sy} = 0.037$ (Negative moment at continuous edge)

$\beta_{sy} = 0.028$ (Positive moment at mid-span)

$n = w = 10.440$ kN/m² (From the example in Step 12)

$$M_{sx.support} = \beta_{sx} n l_x^2 = 0.055 \times 10.440 \text{ kN/m}^2 \times 5.000^2 = -14.355 \text{ kN.m}$$

$$M_{sx.mid-span} = \beta_{sx} n l_x^2 = 0.041 \times 10.440 \text{ kN/m}^2 \times 5.000^2 = 10.701 \text{ kN.m}$$

$$M_{sy.support} = \beta_{sy} n l_x^2 = 0.037 \times 10.440 \text{ kN/m}^2 \times 5.000^2 = -9.657 \text{ kN.m}$$

$$M_{sy.mid-span} = \beta_{sy} n l_x^2 = 0.028 \times 10.440 \text{ kN/m}^2 \times 5.000^2 = 7.308 \text{ kN.m}$$

Step 36: Determine the moment of resistance of each Coffer rib.

The effective depth of the reinforcing steel is required to determine the moment of resistance.

The effective depth 'd' is the depth from external face of the compression zone of the beam to the centre of the tension reinforcement as stated in SABS 0100-1 Ed.2.2, clause 4.3.3.3.

Assume the concrete cover to reinforcing steel = 30 mm (From Step 7).

The relevant cover to reinforcing steel must be chosen depending on the requirement of structure.

Assume the width of the rib to be the width at the bottom of the rib and not the width of the rib at the top where the rib and the structural topping meet.

The width $b_{rib.bot}$ of the rib used in the moment of resistance calculation will then always be taken as 128 mm (Refer to Figure 14).

Assume the redistribution of moments do not exceed 10%, therefore $K = 0.156$ (Refer SABS 0100-1 Ed.2.2, clause 4.3.3.4.1).

Assume concrete strength = 30 MPa (From Step 17).

If the moment of resistance is substantially bigger than the actual maximum bending moments over the complete design, an option would be to increase the concrete strength.

The moment of resistance is determined using the following equation:

$$M_r = K b d^2 f_{cu} \text{ (Refer to SABS 0100-1 Ed.2.2, clause 4.3.3.4.1)}$$

Example:

$b_{rib.bot} = 128$ mm (From above)

$f_{cu} = 30$ MPa (From above)

$K = 0.156$ (Moment distribution smaller than 10%)

$t_{beam} = 425$ mm (From Step 9)

Cover = 30 mm (From above)

Tension reinforcing steel = Y16 (Assumed)

Stirrup = R8 (Assumed)

$$d = t_{beam} - \text{cover} - \text{half bar diameter} - \text{diameter}_{stirrup} = 415 \text{ mm} - 30 \text{ mm} - (16 \text{ mm} \div 2) - 8 \text{ mm} = 379 \text{ mm}$$

$$M_r = K b d^2 f_{cu} = 0.156 \times 128 \text{ mm} \times (379 \text{ mm})^2 \times 30 \text{ MPa} = 0.156 \times 0.128 \text{ m} \times (0.379 \text{ m})^2 \times 0.03 \times 10^6 \text{ kN/m}^2 = 86.047 \text{ kN.m}$$

COFFER SLAB DESIGN

Step 37: Determine the area of tension reinforcing steel required for each rib at mid-span.

Check if only tension reinforcement is required, or if tension and compression reinforcement is required, for the rib.

This is achieved by checking the 'K' value with the applied bending moment, where:

$$K = \frac{M_{u,mid}}{bd^2f_{cu}} \quad (\text{Refer to SABS 0100-1 Ed.2.2, clause 4.3.3.4.1})$$

If $K > 0.156$, then compression reinforcing steel is required in addition to the tension reinforcing steel.

This Concrete Design Guide does not deal with the design for compression reinforcing steel.

Example:

This example will only consider the largest mid-span moment, which will always be in the direction of the short span

$$M_{sx,mid-span} = 10.701 \text{ kN.m} \quad (\text{From Step 35})$$

$$b_{rib,bot} = 128 \text{ mm} \quad (\text{From Step 36})$$

$$d = 379 \text{ mm} \quad (\text{From Step 36})$$

$$f_{cu} = 30 \text{ MPa} \quad (\text{From Step 17})$$

$$K = \frac{M_{u,mid}}{bd^2f_{cu}} = \frac{10.701 \text{ kN.m}}{128 \text{ mm} \times (379 \text{ mm})^2 \times 30 \text{ MPa}} = \frac{10.701 \text{ kN.m}}{0.128 \text{ m} \times (0.379 \text{ m})^2 \times 30 \text{ kN/m}^2} = \mathbf{0.019}$$

$K < 0.156$, therefore only tension reinforcement is required

Determine the lever arm 'z'

The value of 'z' is the lesser of $0.95d$ and $d \times (0.5 + \sqrt{(0.25 - (K \div 0.9))})$ (Refer to SABS 0100-1 Ed.2.2, clause 4.3.3.4.1)

The required area of tension reinforcement at mid-span is determined using the following equation:

$$A_{s,req} = \frac{M_{u,mid}}{0.87f_y z}$$

The area of tension reinforcing steel should not exceed 4% of the gross cross-sectional area of the beam.

The minimum percentage of reinforcing steel for a flanged beam with the web in tension is given in Table 12.

Table 12 - Minimum Percentage Of Reinforcement			
Tension Reinforcement	Definition Of Percentage	Minimum Percentage	
		$f_y = 250 \text{ MPa}$	$f_y = 450 \text{ MPa}$
Flanged Beam With Web In Tension ($b_w / b_f < 0.4$)	$100 A_s / b_w h$	0.32	0.18

Extract from SABS 0100-1 Ed.2.2, Table 23

Determine the required area of tension reinforcement:

$$M_{sx,mid-span} = 10.701 \text{ kN.m} \quad (\text{From Step 35})$$

$$f_y = 450 \text{ MPa} \quad \text{for hot-rolled high-yield steel} \quad (\text{Refer to SABS 0100-1 Ed.2.2, Table 3})$$

$$d = 379 \text{ mm} \quad (\text{From Step 36})$$

$$z = \text{lesser of } 0.95 \times 379 \text{ mm} = \mathbf{360 \text{ mm}} \text{ and } 379 \times (0.5 + \sqrt{(0.25 - (0.019 \div 0.9))}) = \mathbf{371 \text{ mm}}$$

$$t_{beam} = 425 \text{ mm} \quad (\text{From Step 9})$$

$$b_{rib,ave} = (b_{rib,top} + b_{rib,bot}) \div 2 = (258 \text{ mm} + 128 \text{ mm}) \div 2 = \mathbf{193 \text{ mm}} \quad (\text{From Table 9})$$

$$A_{s,req} = \frac{M_{sx,mid-span}}{0.87f_y z} = \frac{10.701 \text{ kN.m}}{0.87 \times 450 \text{ MPa} \times 360 \text{ mm}} = \frac{10.701 \times 10^3 \text{ kN.mm}}{0.87 \times 450 \times 10^{-3} \text{ kN/mm}^2 \times 360 \text{ mm}} = \mathbf{76 \text{ mm}^2 \text{ per rib}}$$

$$b_w h = b_{rib,ave} \times t_{beam} = 193 \text{ mm} \times 425 \text{ mm} = \mathbf{82.025 \times 10^3 \text{ mm}^2 \text{ per rib}}$$

$$A_{s,min} = 0.18 \times b_w h \div 100 = 0.18 \times 82.025 \times 10^3 \div 100 = \mathbf{148 \text{ mm}^2 \text{ per rib}}$$

$$A_c = (b_{rib,ave} \times h_{rib}) + (b_{topping} \times t_{topping}) = (193 \text{ mm} \times 325 \text{ mm}) + (900 \text{ mm} \times 100 \text{ mm}) = \mathbf{152.725 \times 10^3 \text{ mm}^2 \text{ per rib}}$$

$$A_{s,max} = 4\% \times A_c = 0.04 \times (82.025 \times 10^3 \text{ mm}^2) = \mathbf{3281 \text{ mm}^2 \text{ per rib}}$$

$$A_{s,max} > A_{s,req} < A_{s,min} \text{ therefore } A_{s,req} = \mathbf{148 \text{ mm}^2}.$$

COFFER SLAB DESIGN

Step 38: Select the spacing and type of reinforcing steel to be used for the ribs to cater for mid-span bending.

The required area of reinforcing steel for the ribs has been established.

The diameter and spacing of the reinforcing bars must now be determined.

In the Coffer beam calculation the designer assumed a reinforcing bar spacing of 170 mm.

However, the ribs are spaced at 900 mm (As shown in Figure 14), and assuming that only 1 No. reinforcing bar is used per rib, a reinforcing bar spacing of 900 mm is accepted.

The total width of a rib at the bottom is 128 mm (From Table 9), which is less than 170 mm.

If it is not possible to have only one reinforcing bar (due to the imposed moments), the designer can use more reinforcing bars, but the spacing within the rib must be checked to ensure that there is adequate space for concrete to flow around the reinforcing bars.

The required cross-sectional area ($A_{s,req}$) per reinforcing bar can be determined by dividing the total area of reinforcing steel required per metre width by the number of reinforcing bars provided at a spacing of 900 mm.

Table 7 must be used to determine the diameter of the reinforcing bars that are required to meet the minimum cross-sectional area requirements.

The designer must now check that the assumed calculated spacing is smaller than the maximum spacing allowed for the specific section if more than one reinforcing bar is required.

The maximum spacing of reinforcing bars is the smaller of 300 mm or $47000 \div f_s$ (Refer to SABS 0100-1 Ed.2.2, clause 4.11.8.2.1.4). Note that this only applies to slabs and beams.

By default, the ribs are spaced at 900 mm center to center, which is allowed for in the reinforcement calculation.

The service stress $f_s = 0.87f_y \times \frac{y_1 + y_2}{y_3 + y_4} \times \frac{A_{s,req}}{A_{s,prov}} \times \frac{1}{\beta_b}$ (Refer to SABS 0100-1 Ed.2.2, clause 4.3.6.3.1)

Where:

y_1 = self-weight load factor for serviceability limit states = 1.1

y_2 = imposed load factor for serviceability limit states = 1.0

y_3 = self-weight load factor for ultimate limit states = 1.2

y_4 = imposed load factor for ultimate limit states = 1.6

β_b = ratio of resistance moment at mid-span obtained from the redistributed maximum moments diagram to that obtained from the maximum moments diagram before redistribution = 1.0

(Refer to SABS 0100-1 Ed.2.2, clause 4.3.6.3.1; SANS 10160-1, Table 3, and SANS 10160-1, clause 8.3.1.1).

Example:

Number of reinforcing bars = 1 No. per rib (Reinforcing bar spacing is not applicable because only 1 No. reinforcing bar is used)

$b_{rib,bot}$ = 128 mm (From Table 9)

f_y = 450 MPa = 450 N/mm² (From Step 18)

$A_{s,req}$ = 148 mm² per rib (From Step 37)

Area of 1 No. Y16 reinforcing bar = 201 mm² (From Table 7)

$A_{s,prov}$ = 201 mm² which is greater than the required area of 148 mm², therefore 1 No. Y16 reinforcing bar is sufficient to cater for the moment

The service stress $f_s = 0.87 (450 \text{ N/mm}^2) \times \frac{1.1 + 1.0}{1.2 + 1.6} \times \frac{148 \text{ mm}^2}{201 \text{ mm}^2} \times \frac{1}{1.0} = 216 \text{ N/mm}^2$

$47000 \div f_s = 47000 \div 216 \text{ N/mm}^2 = 218 \text{ mm}$

By default, the spacing of 218 mm will not be applicable in the rib calculation due to the ribs being at a spacing of 900 mm centre to centre.

COFFER AND TROUGH SLAB DESIGN

COFFER SLAB DESIGN

Step 39: Selecting the number of stirrups for the ribs.

It is good practice to have longitudinal bars in the corners of each stirrup.

The number of stirrups is based on the number of longitudinal tension reinforcing bars present in the rib under consideration.

Each stirrup in the ribs has 2 vertical legs (As shown in Figure 15) which provides a central position at the bottom for 1 No. longitudinal tension reinforcing bar.

The intervals or spacing at which the stirrups are positioned along the length of the rib, is based on the shear resistance required for the rib as discussed in Step 40.

Assume all stirrups are R8 mild steel reinforcing bars.

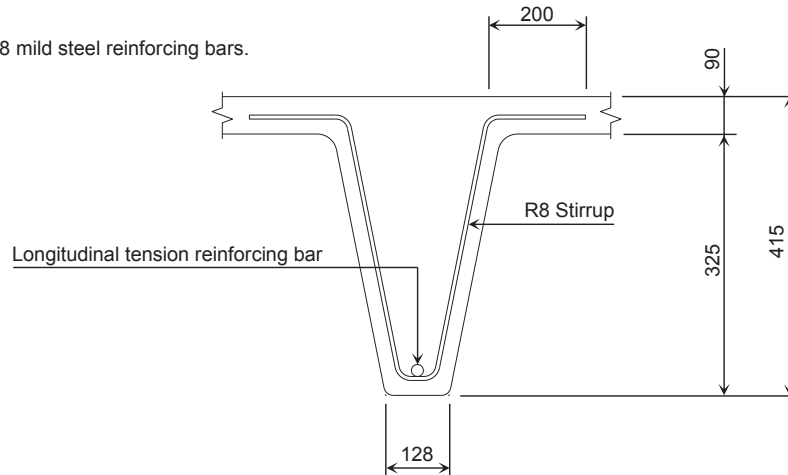

Figure 15 – Typical Cross-Section Showing Stirrup In Coffe Rib

Step 40: Check the shear resistance of the rib.

The design shear force due to the design maximum loads for the ultimate limit state must be determined.

Assuming the ribs are truly simply supported, the designer can conservatively determine the reaction forces at each side of the two-way spanning Coffe slab.

The two formulas below can be used to determine the reaction forces for the ribs in the long and short direction:

$$\text{Trapezoidal load } w = \left(\frac{nl_x}{6} \left(3 - \left(\frac{l_x}{l_y} \right)^2 \right) \right) \times 0.9 \text{ m (Short direction)}$$

$$\text{Triangular load } w = \left(\frac{nl_x}{3} \right) \times 0.9 \text{ m (Long direction)}$$

Note that the results from above formulas are in kN per rib, where the ribs are at a 900 mm spacing

The formulas are multiplied by 0.9 m, to convert the results from kN per m to kN per rib.

Example:

Rib in direction x (short direction):

$$l_{ex} \text{ (Effective length of shorter side of the slab)} = 5000 \text{ mm} = 5.0 \text{ m (From Step 32)}$$

$$l_{ey} \text{ (Effective length of longer side of the slab)} = 6940 \text{ mm} = 6.94 \text{ m (From Step 32)}$$

$$n \text{ (load on slab)} = w_{\text{slab}} = 10.440 \text{ kN/m}^2 \text{ (From Step 12)}$$

$$\text{Trapezoidal load } w = \frac{nl_x}{6} \left(3 - \left(\frac{l_x}{l_y} \right)^2 \right) = \frac{10.440 \text{ kN/m}^2 \times 5.0 \text{ m}}{6} \left(3 - \left(\frac{5.0 \text{ m}}{6.94 \text{ m}} \right)^2 \right) \times 0.9 \text{ m} = \mathbf{19.426 \text{ kN per rib}}$$

Although this load varies, assume the load to be uniform over the length of the rib

The design shear stress 'v' at any x-section of the rib shall not exceed a value of the lesser of $0.75\sqrt{f_{cu}}$ or 4.75 MPa (Refer to SABS 0100-1 Ed.2.2, clause 4.3.4.1.1)

$$\text{Design shear stress } v = \frac{V}{bd} \text{ (Refer to SABS 0100-1 Ed.2.2, clause 4.3.4.1.1)}$$

$$\text{Maximum design shear stress of concrete } v_c = \frac{0.75}{\gamma_m} \left(\frac{f_{cu}}{25} \right)^{1/3} \left(\frac{100A_s}{b_v d} \right)^{1/3} \left(\frac{400}{d} \right)^{1/4} \text{ (Refer to SABS 0100-1 Ed.2.2, clause 4.3.4.1.2)}$$

$\frac{100A_s}{b_v d}$ shall not be taken as greater than 3. (Refer to SABS 0100-1 Ed.2.2, clause 4.3.4.1.2)

The design shear stress should be less than the maximum design shear stress, if not, additional shear reinforcing steel must be added.

The cross-section of a rib cannot be altered to allow for increased shear capacity as was the case in the design of the support beams.

COFFER SLAB DESIGN

To determine the required ratio of shear reinforcement to reinforcing bar spacing, apply the following equation:

$$\frac{A_{sv}}{s_v} \geq \frac{b(v - v_c)}{0.87f_{yv}}$$

Where:

A_{sv} is the cross-sectional area of the two legs of the stirrup

f_{yv} is the characteristic strength of the stirrup reinforcement (R8 = 250 MPa)
(Refer to SABS 0100-1 Ed.2.2, clause 4.3.4.1.3).

Example:

$w_{slab} = 10.440 \text{ kN/m}^2$ (From Step 12)

$l_{ex} = 5000 \text{ mm}$ (From Step 32)

$b_{rib,ave} = (b_{rib,top} + b_{rib,bot}) \div 2 = (258 \text{ mm} + 128 \text{ mm}) \div 2 = \mathbf{193 \text{ mm}}$ (From Table 9)

$d = 379 \text{ mm}$ (From Step 36)

$f_{cu} = 30 \text{ MPa} = 30 \text{ N/mm}^2$ (From Step 17)

$A_{s,prov} = 1 \text{ No. Y16 reinforcing bar} = 201 \text{ mm}^2$ (From Step 38)

Partial safety factor for materials for shear strength without shear reinforcement and shear taken by concrete in combination with shear reinforcement $\gamma_m = 1.40$ (Refer to SABS 0100-1 Ed.2.2, clause 3.3.3.2)

Design Shear Force $V = w_{rib} = 19.426 \text{ kN}$ per rib (From above)

(The designer should prepare a proper beam analysis to determine the reaction forces on each support using specialist software packages)

$$\text{Design shear stress } v = \frac{V}{bd}$$

$$v = \frac{19.426 \text{ kN}}{193 \text{ mm} \times 379 \text{ mm}} = \frac{19.426 \times 10^3 \text{ N}}{193 \text{ mm} \times 379 \text{ mm}} = 0.266 \times 10^3 \text{ N/mm}^2 = \mathbf{0.266 \text{ MPa}}$$

Maximum shear stress $v_{max} = \text{smaller of } 0.75\sqrt{30} = \mathbf{4.108 \text{ MPa}}$ and 4.75 MPa

$v < v_{max}$ therefore okay

$$\frac{100A_s}{b_v d} = \frac{100 \times 201 \text{ mm}^2}{193 \text{ mm} \times 379 \text{ mm}} = \mathbf{0.275} < 3, \text{ therefore okay}$$

$$v_c = \frac{0.75}{1.4} \left(\frac{30 \text{ N/mm}^2}{25} \right)^{1/3} (0.275)^{1/3} \left(\frac{400}{379 \text{ mm}} \right)^{1/4} = 0.375 \text{ N/mm}^2 = \mathbf{0.375 \text{ MPa}}$$

$v < v_c$ therefore no additional shear reinforcement is required

$$\frac{A_{sv}}{s_v} \geq \frac{b(v - v_c)}{0.87f_{yv}}$$

Where:

A_{sv} is the cross-sectional area of the two legs of a stirrup

f_{yv} is the characteristic strength of the stirrup reinforcement (R8 = 250 MPa)
(Refer to SABS 0100-1 Ed.2.2, clause 4.3.4.1.3)

$$\frac{A_{sv}}{s_v} \geq \frac{193 \text{ mm} (0.266 \text{ N/mm}^2 - 0.375 \text{ N/mm}^2)}{0.87 \times 250 \text{ N/mm}^2} = \mathbf{-0.097}$$
 (This ratio will be used in Step 41 to determine the spacing of the stirrups)

The negative value is a further indication that no shear reinforcement is required and that the longitudinal tension reinforcement is sufficient to cater for the shear.

COFFER AND TROUGH SLAB DESIGN

COFFER SLAB DESIGN

Step 41: Determine the spacing of the stirrups in the ribs.

s_v is the spacing of the stirrups along a rib.

The spacing should not exceed 0.75 times the effective depth of the reinforcement.

The initial assumption is made that the spacing of the stirrups is just below 0.75 times the effective depth of the reinforcing steel.

If the assumed spacing of the stirrups is found to be insufficient, the spacing must be reduced accordingly.

If the following equation is true, then the spacing is okay, if not, reduce the spacing:

$$\frac{A_{sv}}{s_v} \geq \frac{b(v - v_c)}{0.87f_{yv}}$$

Where:

A_{sv} = the cross-sectional area of the two legs of a stirrup

f_{yv} = the characteristic strength of the stirrup reinforcement (R8 = 250 MPa)
(Refer to SABS 0100-1 Ed.2.2, clause 4.3.4.1.3)

Example:

$d = 379$ mm (From Step 36)

$s_{v,max} = 0.75d = (0.75 \times 379 \text{ mm}) = \mathbf{284}$ mm

Assume stirrup spacing $s_v = 250$ mm

$s_v < s_{v,max}$ therefore okay

Number of R8 stirrups = 1 No. (From Figure 15)

Thus number of legs = 1 No. stirrup \times 2 legs per stirrup = **2** No. legs

R8 cross-sectional area = 50 mm² (Refer to Table 7)

$A_{sv,prov} = 2 \text{ No.} \times 50 \text{ mm}^2 = \mathbf{100}$ mm²

$$\frac{A_{sv}}{s_v} = -0.097 \text{ (From Step 40)}$$

$A_{sv,req} = -0.097 \times 250 \text{ mm} = \mathbf{-24.25}$ mm². The area required cannot be less than 0, therefore accept R8 stirrups at a spacing of 250 mm

$A_{sv,prov} > A_{sv,req}$ therefore okay.

Step 42: Determine the area of nominal reinforcing steel at mid-span and at the supports for the Cofferslab.

A single layer of mesh reinforcement should be provided to control cracking in the structural topping.

The mesh should have a cross-sectional area of at least 0.12% of the cross-sectional area of the topping, in each direction, and the spacing of the bars in the mesh should not exceed half the centre to centre distance between the ribs.
(Refer to SABS 10100-1 Ed.2.2, clause 4.5.6.2.2).

Example:

$t_{topping} = 100$ mm (From Step 9)

$b_{topping} = 900$ mm per rib

$A_c = t_{topping} \times b_{topping} = 100 \text{ mm} \times 900 \text{ mm} = \mathbf{90.0 \times 10^3}$ mm²

$A_{s,mesh} = 0.12 \% \times 90.0 \times 10^3 \text{ mm}^2 = \mathbf{108}$ mm² per 900 mm wide structural topping over each rib

Referring to Table 13, Mesh Ref 245 = **124.8** mm² > 108 mm²

Use Mesh Ref 245 for the nominal reinforcement.

Table 13 - Mesh Reinforcement

Mesh Reference	Wire / Bar Diameter (mm)	Wire / Bar Spacing (mm)	Cross Sectional Area Per 900 mm Width (mm ²)
Ref 888	12.0	200 x 200	452.8
Ref 617	10.0	200 x 200	314.4
Ref 500	9.0	200 x 200	254.4
Ref 395	8.0	200 x 200	200.8
Ref 311	7.1	200 x 200	158.4
Ref 245	6.3	200 x 200	124.8
Ref 193	5.6	200 x 200	98.4
Ref 100	4.0	200 x 200	50.4

COFFER SLAB DESIGN

Step 43: Determine the area of tensile reinforcing steel required for the rib at the support beam.

Check if only tension reinforcing steel is required, or if tension and compression reinforcing steel is required, for the rib.

This is achieved by checking the 'K' value with the applied bending moment, where:

$$K = \frac{M_{u,sup}}{bd^2f_{cu}} \quad (\text{Refer to SABS 0100-1 Ed.2.2, clause 4.3.3.4.1})$$

If $K > 0.156$, then compression reinforcing steel is required in addition to the tension reinforcing steel.

This Concrete Design Guide does not deal with the design for compression reinforcing steel.

Example:

$$b_{rib,ave} = (b_{rib,top} + b_{rib,bot}) \div 2 = (258 \text{ mm} + 128 \text{ mm}) \div 2 = 193 \text{ mm} \quad (\text{From Table 9})$$

$$M_{sx,support} = - 14.355 \text{ kN.m} \quad (\text{From Step 35})$$

$$d = 379 \text{ mm} \quad (\text{From Step 36})$$

$$f_{cu} = 30 \text{ MPa} \quad (\text{From Step 17})$$

$$K = \frac{14.355 \text{ kN.m}}{193 \text{ mm} \times (379 \text{ mm})^2 \times 30 \text{ MPa}} = \frac{14.355 \text{ kN.m}}{0.193 \text{ m} \times (0.379 \text{ m})^2 \times 30 \times 10^3 \text{ kN/m}^2} = 0.017$$

Thus $K < 0.156$, therefore only tension reinforcing steel is required

Determine the lever arm 'z'

The value of 'z' is the lesser of $0.95d$ and $d \times (0.5 + \sqrt{(0.25 - (K \div 0.9))})$ (Refer to SABS 0100-1 Ed.2.2, clause 4.3.3.4.1)

The required area of tension reinforcing steel is determined using the following equation:

$$A_{s,req} = \frac{M_{u,sup}}{0.87f_y z}$$

The area of tension reinforcing steel should not exceed 4% of the gross cross-sectional area of the beam.

The minimum percentage of reinforcing steel for a flanged beam is given in Table 14.

Table 14 - Minimum Percentage Of Reinforcement			
Tension Reinforcement	Definition Of Percentage	Minimum Percentage	
		$f_y = 250 \text{ MPa}$	$f_y = 450 \text{ MPa}$
Flanged Beam With Flange In Tension Over Continuous Support ($b_w / b_f < 0.4$)	$100 A_s / b_w h$	0.48	0.26

$$M_{sx,support} = - 14.355 \text{ kN.m} \quad (\text{From Step 35})$$

$f_y = 450 \text{ MPa}$ for hot-rolled high-yield steel (Refer to SABS 0100-1 Ed.2.2, Table 3)

$$d = 379 \text{ mm} \quad (\text{From Step 36})$$

$$z = \text{lesser of } 0.95 \times 379 \text{ mm} = 360 \text{ mm} \text{ and } 379 \times (0.5 + \sqrt{(0.25 - (0.017 \div 0.9))}) = 372 \text{ mm}$$

$$t_{topping} = 100 \text{ mm} \quad (\text{From Step 9})$$

$$b_{topping} = 900 \text{ mm per rib} \quad (\text{From Step 42})$$

$$A_{s,req} = \frac{14.355 \text{ kN.m}}{0.87 \times 450 \text{ MPa} \times 360 \text{ mm}} = \frac{14.355 \times 10^3 \text{ kN.mm}}{0.87 \times 450 \times 10^{-3} \text{ kN/mm}^2 \times 360 \text{ mm}} = 102 \text{ mm}^2$$

$$A_c = t_{topping} \times b_{topping} = 100 \text{ mm} \times 900 \text{ mm} = 90.0 \times 10^3 \text{ mm}^2$$

$$A_{s,min} = 0.26 \times A_c \div 100 = 0.26 \times 90.0 \times 10^3 \text{ mm}^2 \div 100 = 234 \text{ mm}^2$$

$$A_{s,max} = 4\% \times A_c = (0.04 \times 90.0 \times 10^3 \text{ mm}^2) = 3600 \text{ mm}^2$$

$A_{s,max} > A_{s,req} < A_{s,min}$ therefore $A_{s,req} = 234 \text{ mm}^2$ per rib (Or every 900 mm center to center of ribs).

COFFER SLAB DESIGN

Step 44: Select the spacing and type of tensile reinforcing steel to be used at the rib support for bending.

The required area of tensile reinforcing steel required for the rib at the support beam has been established.

The diameter and spacing of the reinforcing bars must now be determined.

The designer can assume the spacing between top tensile reinforcing bars to be 900 mm centre to centre, because this is the spacing of the ribs.

Compare the cross-sectional area determined in Step 43 to the values given in Table 7, to determine the minimum diameter of the reinforcing bars required.

Note:

If there is a marginal shortfall of top reinforcement, the mesh reinforcing steel in the structural topping should be taken into account, as calculated in Step 42.

Example:

$$b_{\text{topping}} = 900 \text{ mm per rib (From Step 43)}$$

$$f_y = 450 \text{ MPa} = 450 \text{ N/mm}^2 \text{ for hot-rolled high-yield steel (Refer to SABS 0100-1 Ed.2.2, Table 3)}$$

$$A_{s,\text{req}} = 234 \text{ mm}^2 \text{ per 900 mm rib spacing (From Step 43) due to the minimum cross-sectional area of the concrete structural topping}$$

$$A_{s,\text{req}} = 102 \text{ mm}^2 \text{ per 900 mm rib spacing (From Step 43) due to the actual support moment}$$

$$A_{s,\text{mesh}} = 125 \text{ mm}^2 \text{ per 900 mm wide structural topping over each rib (From Step 42)}$$

$$\text{Therefore, the new area of steel required } A_{s,\text{req,new}} = 234 \text{ mm}^2 - 125 \text{ mm}^2 = \mathbf{109 \text{ mm}^2}$$

From Table 7, 1 No. Y12 reinforcing bar with a cross-sectional area of 113 mm² in the structural topping is sufficient

$$\text{The total area } A_{s,\text{prov}} = 125 \text{ mm}^2 + 113 \text{ mm}^2 = \mathbf{238 \text{ mm}^2}$$

$$A_{s,\text{prov}} > A_{s,\text{req}} \text{ therefore tension reinforcing steel okay}$$

$$\text{The service stress } f_s = 0.87 (450 \text{ N/mm}^2) \times \frac{1.1 + 1.0}{1.2 + 1.6} \times \frac{234 \text{ mm}^2}{238 \text{ mm}^2} \times \frac{1}{1.0} = \mathbf{289 \text{ N/mm}^2}$$

$$47000 \div f_s = 47000 \div 289 \text{ N/mm}^2 = \mathbf{163 \text{ mm}}$$

The mesh reinforcing bar spacing of 200 mm for is larger than the maximum spacing of 163 mm.

In this case, the 1 No. Y12 provided (113 mm²) is larger than the actual area of steel required due to the moment (102 mm²), therefore the spacing can be ignored.

COFFER SLAB DESIGN

Step 45: Check the deflections based on the basic allowable span of the ribs.

To prevent damage to finishes and partitions for beams with spans up to 10 m, the deflection must be limited to span divided by 250.

The basic span/effective depth ratios are given in Table 4.

Serviceability Limit State Load = 1.1DL + 1.0LL (Refer to SANS 10160-1, clause 8.3.1.1).

The basic span/effective depth ratio value obtained from Table 4 must be modified with a modification factor that takes into account the amount of tension reinforcement and the associated stresses when the allowable span/effective depth ratio is calculated.

The modification factor is derived from the following equation:

$$\text{Modification factor} = 0.55 + \frac{477 - f_s}{120 \left(0.9 + \frac{M_u}{bd^2} \right)} \leq 2.0 \quad (\text{Refer to SABS 0100-1 Ed.2.2, clause 4.3.6.3.1})$$

The allowable span/effective depth ratio will then be the basic span/effective depth ratio multiplied by the calculated modification factor.

The actual span/effective depth ratio can now be calculated from the rib layout shown in Figure 13.

If the actual span/effective depth ratio is bigger than the allowable span/effective depth ratio, the rib fails due to deflection.

Example:

End span condition = Continuous both ends (Designer to determine this from the layout drawing)

DL_{slab} = 6.700 kN/m² (From Step 9)

DL_{rib} = 6.700 kN/m² x 0.9 m per rib = **6.030** kN/m per rib

LL_{slab} = 1.5 kN/m² (From Step 12).

LL_{rib} = 1.5 kN/m² x 0.9 m per rib = **1.350** kN/m per rib

Rib Ultimate Load w_{rib} = (1.2 x 6.030 kN/m) + (1.6 x 1.35 kN/m) = **9.396** kN/m per rib

Rib Serviceability load w_{rib} = (1.1 x 6.030 kN/m) + (1.0 x 1.35 kN/m) = **7.983** kN/m per rib

Determine the service stress:

A_{s,req} = 148 mm² per rib (From Step 37)

A_{s,prov} = 201 mm² (From Step 38)

f_y = 450 MPa = 450 N/mm² (From Step 18)

The service stress f_s = 0.87(450 MPa) x $\frac{y_1 + y_2}{y_3 + y_4}$ x $\frac{A_{s,req}}{A_{s,prov}}$ x $\frac{1}{\beta_b}$ (Refer to SABS 0100-1 Ed.2.2, clause 4.3.6.3.1)

$$\text{Service stress } f_s = 0.87 (450 \text{ MPa}) \times \frac{7.983 \text{ kN/m}}{9.396 \text{ kN/m}} \times \frac{148 \text{ mm}^2}{201 \text{ mm}^2} \times \frac{1}{1} = 0.87 (450 \text{ N/mm}^2) \times \frac{7.983 \times 10^6 \text{ N/mm}}{9.396 \times 10^6 \text{ N/mm}} \times \frac{148 \text{ mm}^2}{201 \text{ mm}^2} \times \frac{1}{1} = \mathbf{245 \text{ N/mm}^2}$$

Calculate the modification factor:

M_{sx,mid-span} = 10.701 kN.m (From Step 35)

d = 379 mm (From Step 36)

b_{rib,ave} = (b_{rib,top} + b_{rib,bot}) ÷ 2 = (258 mm + 128 mm) ÷ 2 = **193** mm (From Table 9)

$$\text{Modification factor} = 0.55 + \frac{477 - f_s}{120 \left(0.9 + \frac{M_u}{bd^2} \right)} = 0.55 + \frac{477 \text{ N/mm}^2 - 245 \text{ N/mm}^2}{120 \left(0.9 \text{ N/mm}^2 + \frac{10.701 \times 10^6 \text{ N.mm}}{193 \text{ mm} \times (379 \text{ mm})^2} \right)} = \mathbf{2.053}$$

The modification factor of 2.053 is larger than 2.0, therefore take the modification factor as 2.0

Allowable span/effective depth ratio = (Modification factor) x (Basic span/effective depth ratio)

Where:

Basic span/effective depth ratio = 28 (From Table 4)

(Modification factor) x (Basic span/effective depth ratio) = 2.0 x 28 = **56**

l_{ex} = 5000 mm (From Step 31, Figure 13)

Actual span ÷ effective depth = 5000 mm ÷ 379 mm = **13.193**

13.193 < 56 therefore the rib is okay.

COFFER AND TROUGH SLAB DESIGN

COFFER SLAB DESIGN

Step 46: Calculate the actual long-term deflections of the ribs.

Determine the Moment of Inertia for the cross-sectional area of the rib.

This is done by taking the width and the thickness of the rib into consideration using the following formula:

$$I_x = \frac{bh^3}{12}$$

The short-term modulus of elasticity for the specified strength of the concrete can be determined using Table 8 (Refer to Step 27).

For long term deflections, a conservative assumption is that the modulus of elasticity is only half the value given in Table 8.

Long term deflections can then be determined using one of the following equations:

$$\text{Truly simply supported beam } \delta = \frac{5wl^4}{384E_c I_x}$$

$$\text{Beam with one end continuous } \delta = 0.0099 \frac{wl^4}{E_c I_x}$$

$$\text{Beam with both ends continuous } \delta = 0.0068 \frac{wl^4}{E_c I_x}$$

The recommended limit to prevent damage to finishes and partitions is the span divided by 250 (Refer to SABS 0100-1 Ed.2.2, clause 4.3.6.2.1).

If the calculated actual long-term deflection is less than the recommended limit, then the beam is okay.

Example:

$$b_{\text{rib,ave}} = (b_{\text{rib,top}} + b_{\text{rib,bot}}) \div 2 = (258 \text{ mm} + 128 \text{ mm}) \div 2 = \mathbf{193 \text{ mm}}$$
 (From Table 9)

$$h = t_{\text{beam}} = 425 \text{ mm}$$
 (From Step 9)

Rib Serviceability Load $w_{\text{rib}} = 7.983 \text{ kN/m}^2$ (from Step 45)

$$l_{\text{ex}} = 5000 \text{ mm}$$
 (From Step 32)

$$I_x = \frac{bh^3}{12} = \frac{193 \text{ mm} \times (425 \text{ mm})^3}{12} = \mathbf{1.235 \times 10^9 \text{ mm}^4}$$

$$f_{\text{cu}} = 30 \text{ MPa}$$
 (From Step 17)

$$E_c = 28 \text{ GPa}$$
 (From Table 8), therefore $E_c = 28 \text{ GPa} \div 2 = \mathbf{14 \text{ GPa}}$

End span condition = Continuous both ends

Actual long-term deflection:

$$\delta = 0.0068 \frac{5wl^4}{384E_c I_x} = \frac{0.0068 \times (7.983 \text{ kN/m}) \times (5000 \text{ mm})^4}{(14 \times 10^3 \text{ GPa}) \times (1.235 \times 10^9 \text{ mm}^4)} = \frac{0.0068 \times (7.983 \times 10^3 \text{ kN/mm}) \times (5000 \text{ mm})^4}{(14 \times 10^6 \text{ kN/mm}^2) \times (1.235 \times 10^9 \text{ mm}^4)} = \mathbf{2.0 \text{ mm}}$$

$$\text{Recommended limit} = \frac{\text{Span}}{250} = \frac{5000 \text{ mm}}{250} = \mathbf{20.0 \text{ mm}}$$

2.0 mm < 20.0 mm therefore the deflection of the rib is okay.

COFFER SLAB DESIGN

Step 47: Steel detailing of mid-span tension reinforcing steel for the ribs.

The following rules must be taken into consideration when detailing mid-span tension reinforcement:

Rule 1. Span:

- 1.1 The assumption is made that the Span Length 'L' equals the lesser of the clear span plus the effective depth and the distance from centre line to centre line of the supports.

Rule 2. Simply supported beams:

- 2.1 At least 50% of the tension reinforcing steel at mid-span shall extend to the supports and have an effective anchorage of 12 bar diameters beyond the centre line of the support.
- 2.2 No hook or bend shall begin before the centre line.
- 2.3 At least 25% of the reinforcing steel shall extend to within 0.08L of the support centre line and the rest shall extend to within 0.15L of the support centre line.

Rule 3. Cantilever beams:

- 3.1 At least 50% of the tension reinforcing steel shall extend to the end of the cantilever (and be turned down for bond if necessary) and the remaining reinforcing steel shall extend to a distance (from the face of the support) of the greater of 0.5L and 45 bar diameters.

Rule 4. Continuous beams:

- 4.1 At least 30% of the bottom reinforcing steel in tension at mid-span shall extend to the supports.
- 4.2 Half the remainder shall extend to within 0.2L of the centre line of internal supports.
- 4.3 The remaining 35% shall extend to within 0.1L of the centre line of supports.
- 4.4 At a non-continuous end, 50% of the tension reinforcing steel shall extend to the supports and terminate in an effective anchorage as in Rule 2 above and the remainder must extend to within 0.05L of the centre line of the support.

(Refer to SABS 0144 Ed.3, clauses 7.10.4 and 7.10.5).

Only the reinforcement required for the short span needs to be determined.

The same reinforcement configuration can then be applied to the ribs in the long span.

Example:

$b = 128 \text{ mm}$ (From Table 9)

Tension reinforcement = 1 No. of Y16 reinforcing bar (From Step 38)

The rib in the short direction is continuous both ends (Refer to Figure 16, Section A - A)

Clear span = 3600 mm (From Figure 13)

Supports = 1400 mm (From Figure 13)

$d = 379 \text{ mm}$ (From Step 36)

Span Length 'L' = lesser of $(3600 \text{ mm} + 379 \text{ mm}) = 3979 \text{ mm}$ and $(3600 \text{ mm} + 700 \text{ mm} + 700 \text{ mm}) = 5000 \text{ mm}$.

It is recommended that the above rules are used as a guideline only.

The reinforcing configuration, type, size, and amount or reinforcing steel detailed, will vary between designers and detailers.

It is recommended that reinforcing steel is detailed using the minimum amount of bars and lengths of bars.

Using many different bar lengths and configurations will increase the risk of fixing errors and fixing time on site.

It is further recommended that bottom steel is detailed to pass the centre line of the supports by the anchorage length given in Rule 2.1 above.

In this case, Y16 reinforcing bars are used for bottom steel, therefore each reinforcing bar should pass the centre line of the supports by at least $16 \text{ mm} \times 12 \text{ times the diameter} = 192 \text{ mm}$. (Refer to Figure 16).

This same configuration is then accepted for both the short and long span of the ribs.

COFFER AND TROUGH SLAB DESIGN

COFFER SLAB DESIGN

Figure 16 shows the tension reinforcement for the short span ribs.

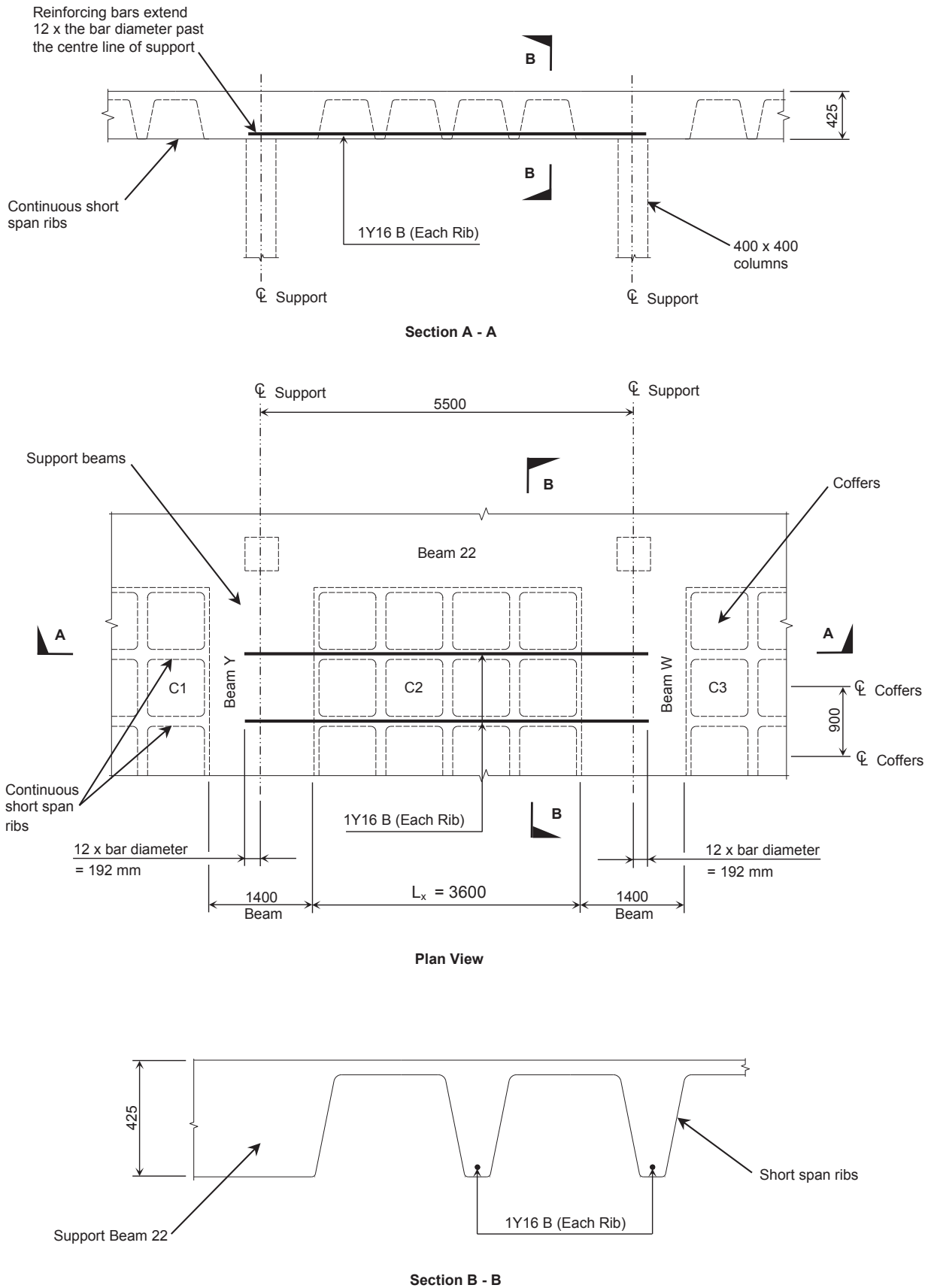

Figure 16 – Bottom Tension Reinforcement For Short Span Ribs

COFFER SLAB DESIGN

Step 48: Steel detailing of the stirrups for the ribs of the Coffer slab.

The designer may increase the spacing to achieve a more economical design, provided the spacing is below the maximum spacing of 0.75d.

Provide R8 stirrups at a 250 mm spacing (From Step 41), along the full length of the short span rib.

For this example, no additional reinforcement will be provided at the top of each stirrup, other than the layer of mesh Ref 245.

In addition to the bottom tension reinforcement, Figure 17 shows the reinforcing stirrups for the short span ribs.

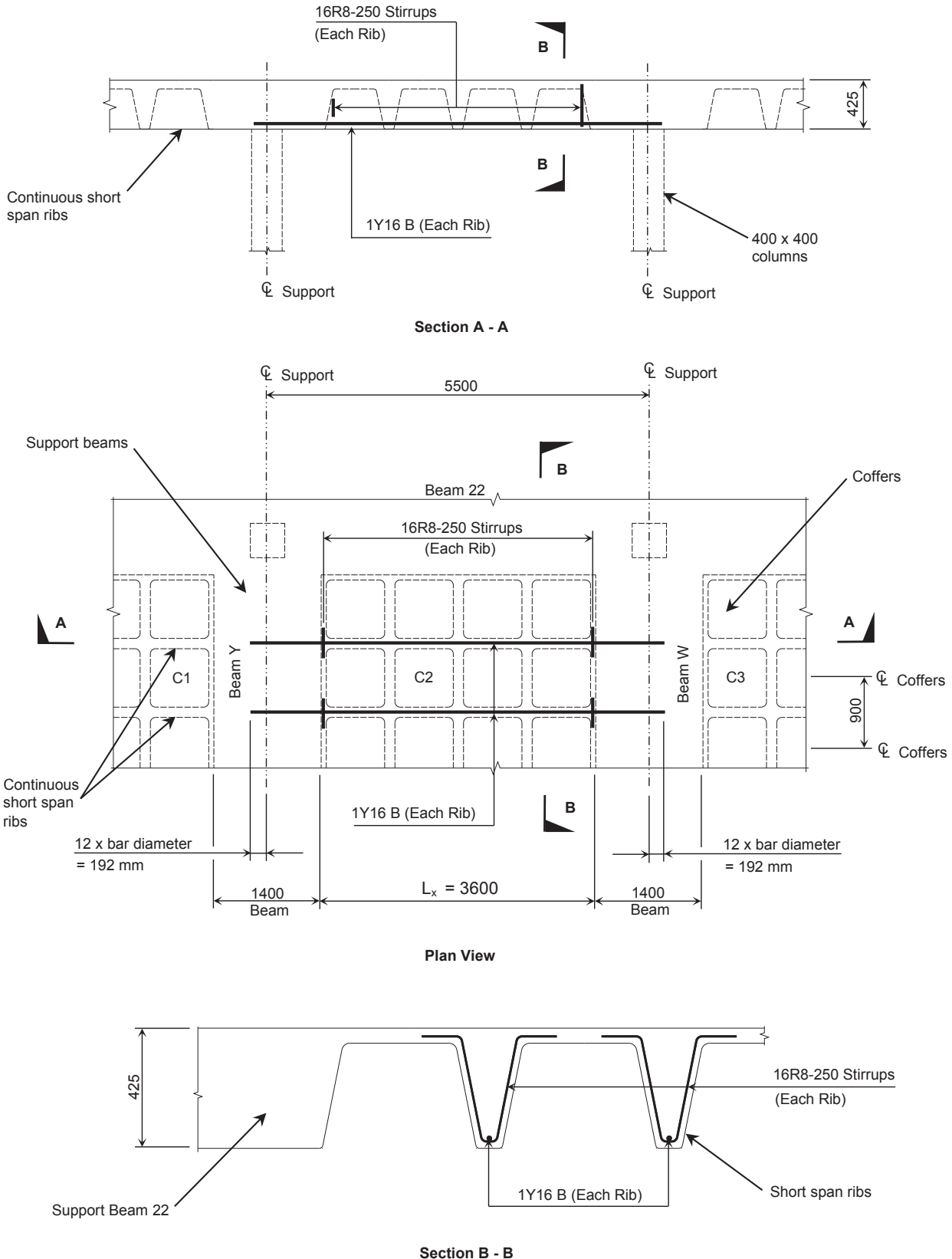

Figure 17 – Bottom Tension Reinforcement And Stirrups For Short Span Ribs

COFFER SLAB DESIGN

Step 50: Steel detailing of tension reinforcing steel at the support and the nominal top reinforcing steel at mid-span.

The following rules must be taken into consideration when detailing mid-span tension reinforcing steel:

Rule 1. Span:

- 1.1 The assumption is made that the Span Length 'L' equals the lesser of the clear span plus the effective depth and the distance from centre line to centre line of the supports.

Rule 2. Simply supported beams:

- 2.1 No tension reinforcement in top of beam required at support.

Rule 3. Cantilever beams:

- 3.1 At least 50% of the tension reinforcing steel shall extend to the end of the cantilever (and be turned down for bond if necessary) and the remaining reinforcing steel shall extend to a distance (from the face of the support) of the greater of 0.5L and 45 bar diameters.

Rule 4. Continuous beams:

- 4.1 At least 20% of the top reinforcement in tension over supports of a continuous beam should be made effectively continuous through the spans.
- 4.2 Half the remainder shall extend to within 0.25L from the face of the support.
- 4.3 The remaining reinforcement shall extend to a point at least 0.15L from the face of the support, but no bar should stop at a point less than 45 bar diameters from the face of the support.

(Refer to SABS 0144 Ed.3, clauses 7.10.4 and 7.10.5.3.3).

Example:

$d_{\text{topping}} = 900 \text{ mm}$ (From Step 37)

Tension rebar = 1 No. Y12 reinforcing bar at a spacing of 900 mm (From Step 44)

The rib in the short direction is continuous both ends (Refer to Figure 19, Section A - A)

Clear span = 3600 mm (From Figure 13)

Supports = 1400 mm (From Figure 13)

$d = 379 \text{ mm}$ (From Step 36)

Span Length 'L' = lesser of $(3600 \text{ mm} + 379 \text{ mm}) = 3979 \text{ mm}$ and $(3600 \text{ mm} + 700 \text{ mm} + 700 \text{ mm}) = 5000 \text{ mm}$.

It is recommended that the above rules are used as a guideline only.

The reinforcing configuration, type, size, and amount of reinforcing steel detailed, will vary between designers and detailers.

It is recommended that reinforcing steel is detailed using the minimum amount of bars and lengths of bars.

Using many different bar lengths and configurations will increase the risk of fixing errors and fixing time on site.

At least 20% of the top tension reinforcing steel should be continuous through the spans.

It is recommended that the remaining 80% of the top reinforcing steel extends to within 0.25L or 45 x bar diameter from the face of the support, whichever is the larger length.

In this case, 1 No. Y12 is used for the top reinforcing steel.

This reinforcing bar should extend past the face of the support by the larger of $(0.25 \times 3979 \text{ mm}) = 995 \text{ mm}$ and $(45 \times 12 \text{ mm diameter}) = 540 \text{ mm}$.

Extend the reinforcing bar 995 mm (Rounded off = 1000 mm) past the face of the support (Refer to Figure 19).

COFFER AND TROUGH SLAB DESIGN

COFFER SLAB DESIGN

In addition to the bottom tension reinforcement, stirrups and mesh, Figure 19 shows the top tension reinforcement.

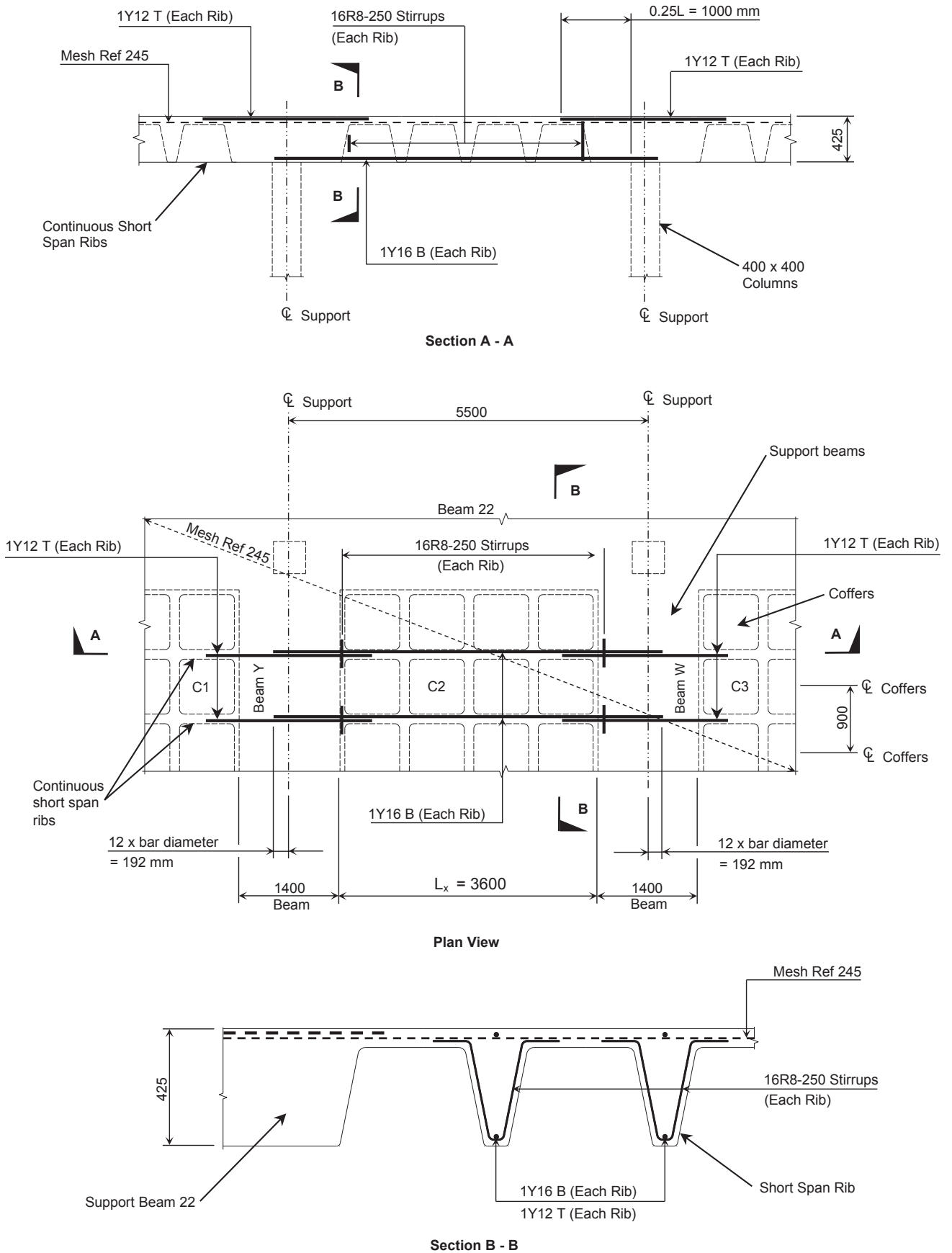
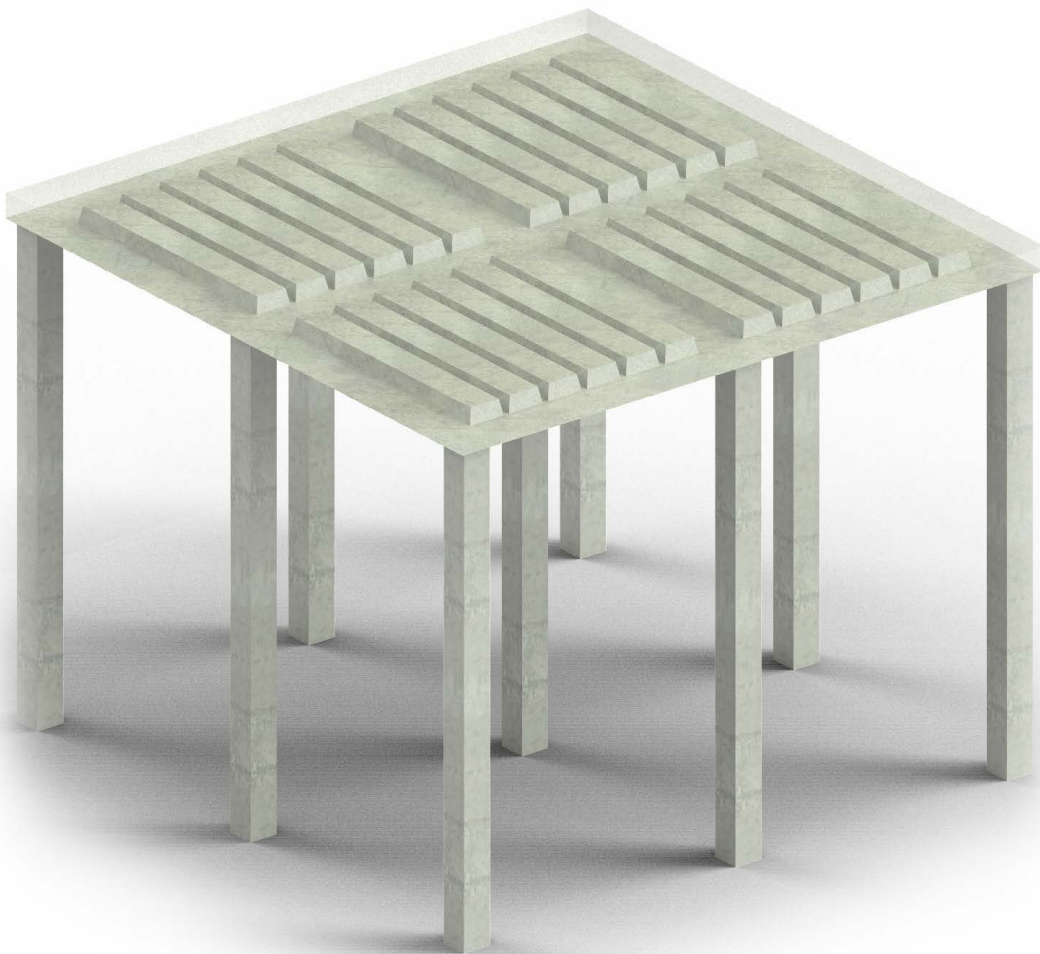

Figure 19 – Top And Bottom Reinforcement, Stirrups And Mesh For Short Span Ribs

Use the same reinforcing steel configuration for the ribs in both directions, except where there are major differences in span lengths.

Work through Steps 1 to 50 until all the beams and ribs are designed.

TROUGH SLAB DESIGN



COFFER AND TROUGH SLAB DESIGN

TROUGH SLAB DESIGN

Design procedure

To simplify the design of Trough slabs, a recommended step by step procedure is given in Table 15 below.

Steps 1 to 50 given in Table 15 are explained in more detail on Pages 61 to 103.

Table 15 should also be used in conjunction with the "Design Flow Diagram" shown on Page 57.

Table 15 - Step By Step Design Procedure For Trough Slabs			
Trough support beam and slab identification	Identify and determine the layout of the Trough slab and beams	Step 1	Fill the complete slab with Troughs and internal beams while leaving beams around the perimeter
		Step 2	Identify all the load bearing walls that are supported on top of the slab
		Step 3	Identify the columns and beams
		Step 4	Determine the Trough lengths
		Step 5	Draw a preliminary Trough slab layout
	Determine thickness of the Trough slab and beams	Step 6	Identify the beam with the worst-case deflection scenario based on the L/d values given in Table 4
		Step 7	Determine the required slab thickness due to deflection
		Step 8	Determine the Trough height and structural topping thickness
	Determine the self-weight and imposed loads	Step 9	Determine the self-weight of the slab
		Step 10	Determine the self-weight of the beam
		Step 11	Determine the imposed loading acting on the slab and beam
		Step 12	Determine the loads acting on the slab and beam
Trough support beam design	Determine the loads acting on the beams	Step 13	Identify the Trough configuration acting on each beam
		Step 14	Determine the impact of Trough slabs acting on the beam
		Step 15	Determine the total load acting on the beam
	Determine the mid-span moments and the tension reinforcing steel required	Step 16	Determine the maximum mid-span bending moment for the beam
		Step 17	Determine the moment of resistance for the beam
		Step 18	Determine the area of tension reinforcing steel required for the beam at mid-span
		Step 19	Select the spacing and type of tension reinforcing steel to be used for mid-span bending
	Determine the shear reinforcing steel required	Step 20	Determine the required number of stirrups
		Step 21	Checking the shear resistance of a beam
		Step 22	Determine the spacing of stirrups
	Determine the support moments and the tension reinforcing steel required	Step 23	Determine the maximum support bending moment for the beam
		Step 24	Determine the area of tension reinforcing steel required for the beam at the support
		Step 25	Select the spacing and type of tension reinforcing steel to be used for support bending
	Check the deflections for the support beam	Step 26	Check the deflections based on the basic allowable span
		Step 27	Calculate the actual long-term deflections
	Steel detailing of the support beam	Step 28	Steel detailing of mid-span tension reinforcing steel for the support beams
		Step 29	Steel detailing of the stirrups for the support beams of the Trough slab
		Step 30	Steel detailing of beam tension reinforcing steel over supports and nominal top reinforcing steel at mid-span
Trough ribs/slab design	Identify the Trough configuration and the minimum structural topping thickness	Step 31	Rib design - Identify and name the Trough portions between the beams
		Step 32	Select a Trough portion and identify specific the details from the drawing
		Step 33	Determine the minimum structural topping thickness due to deflection, for selected Trough height
	Determine the loads acting on the Trough slab	Step 34	Determine the self-weight of the Trough slab and imposed loads on the Trough slab
		Step 35	Determine the span end conditions and maximum moments of the Trough slab
	Determine the end conditions, mid-span moment resistance and the tension reinforcing steel required for each rib	Step 36	Determine the moment of resistance of each Trough rib
		Step 37	Determine the area of tension reinforcing steel required for each rib at mid-span
		Step 38	Select the spacing and type of reinforcing steel to be used for the ribs to cater for mid-span bending
		Step 39	Select the number of stirrups for the ribs
	Determine the shear reinforcing steel required	Step 40	Check the shear resistance of the rib
		Step 41	Determine the spacing of the stirrups in the ribs
		Step 42	Determine the area of nominal reinforcing steel at mid-span and at the supports for the Trough slab
	Determine the reinforcing steel required at mid-span and supports	Step 43	Determine the area of tensile reinforcing steel required for the rib at the support beam
		Step 44	Select the spacing and type of tensile reinforcing steel to be used at the rib support for bending
		Step 45	Check the deflections based on the basic allowable span of the ribs
	Check deflections for the Trough slab	Step 46	Calculate the actual long-term deflections of the ribs
		Step 47	Steel detailing of midspan tension reinforcing steel for the ribs
	Steel detailing of the Trough slab	Step 48	Steel detailing of the stirrups for the ribs of the Trough slab
		Step 49	Steel detailing of the nominal reinforcing steel at mid-span and the supports for the Trough slab
		Step 50	Steel detailing of tension reinforcing steel at the support and the nominal top reinforcing steel at mid-span

TROUGH SLAB DESIGN

Design Flow Diagram

The Design Flow Diagram below shows the recommended step by step procedure for designing Trough slabs. This step by step procedure should also be used in conjunction with Table 15.

Legend

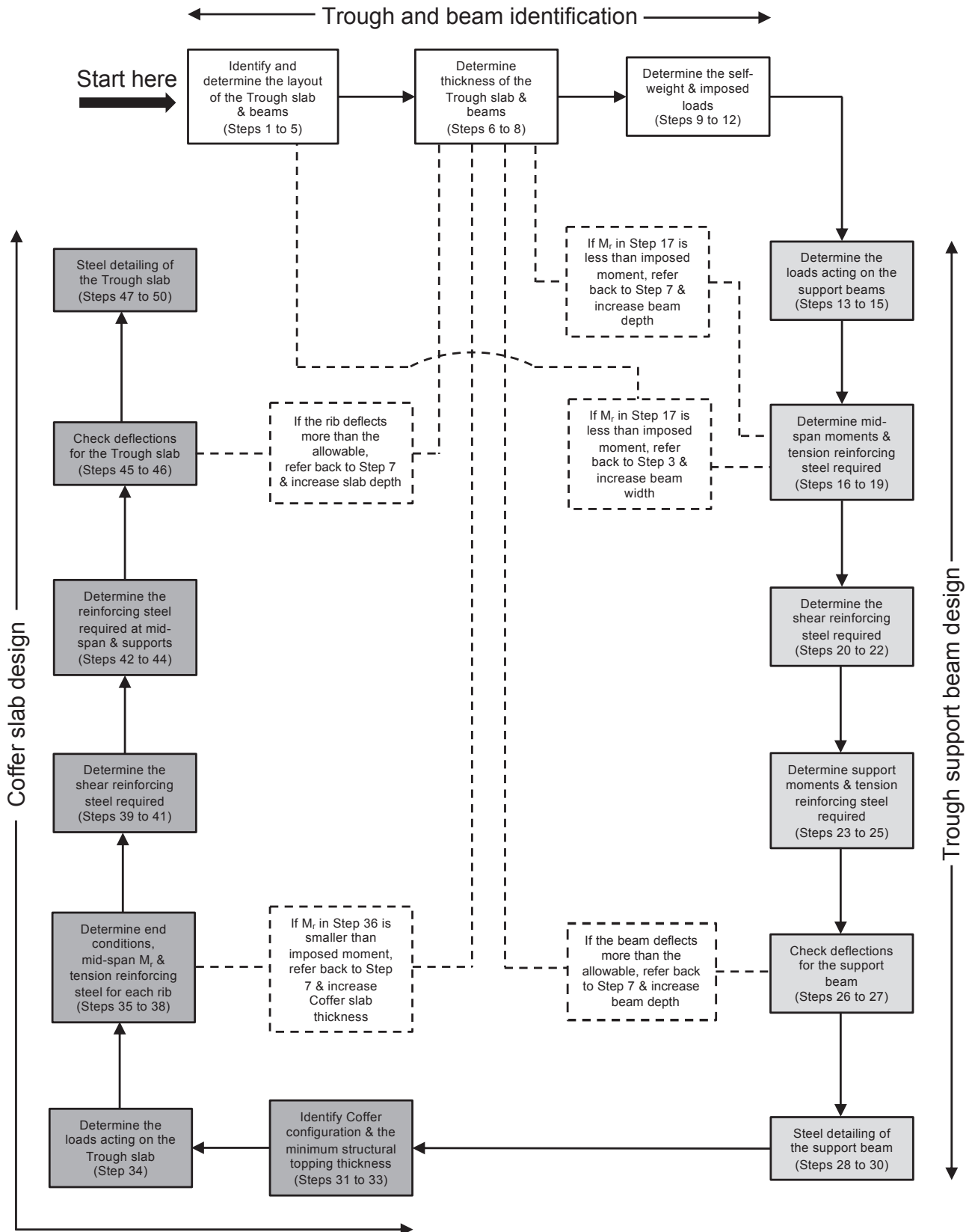
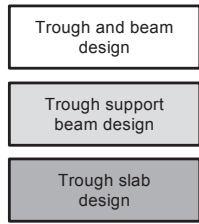

Design Flow Diagram

COFFER AND TROUGH SLAB DESIGN

TROUGH SLAB DESIGN

Trough dimensions and displacement values

Table 16 gives the dimensions and approximate displacement values of the M1500 and M750 Trough Middle sections.

Trough Middle sections are available in three lengths:

- Trough Glassfibre M1500 = 1500 mm long.
- Trough Glassfibre M750 = 750 mm long.
- Trough Glassfibre M500 = 500 mm long.

A 10% tolerance on the displacement values should be taken into consideration due to following reasons:

- Manufacturing variances.
- Repair work and imperfections due to the age of the Troughs.
- Temperature variations.
- Trough movement due to rapid rate of pour.
- Deflection of the glassfibre facing due to the mass of concrete and reinforcing steel.

Note:

The diagrams in Figure 20 show the dimensions of the Trough Middle sections.

The dimensions given in the diagrams are approximate.

The dimensions to the curved surfaces, shown in the diagrams, are to the intersection point of the straight edges.

Both sides of the Trough Middle sections are at an 8:1 slope, or 7.13° angle.

The maximum structural topping permitted on each Glassfibre Troughs 75 mm.

Refer to the Form-Scaff Technical User Guide for details on how to assemble Troughs on the Kwik-Strip system.

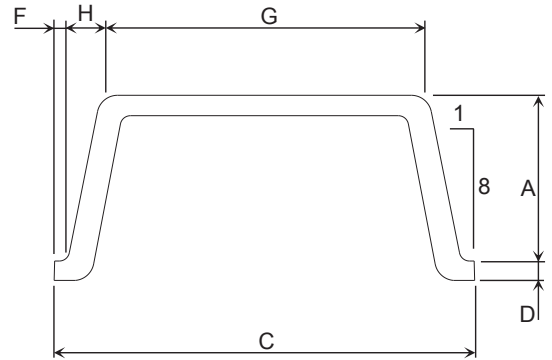

End View A - A

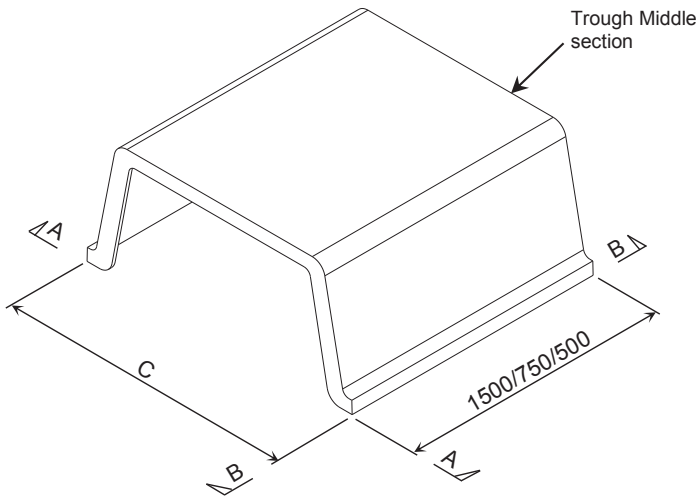

Trough Middle Section - 3D View

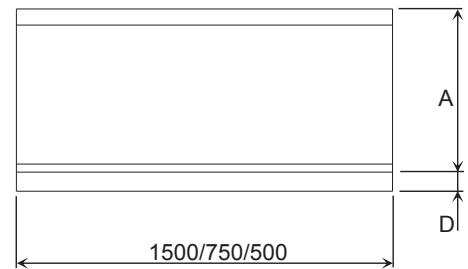

Side View B - B

Figure 20 – Side Views and 3D View Of Troughs

Table 16 - Trough Middle Sections Dimensions And Approximate Displacement Values

Trough Size (mm)	Trough Middle Section Dimensions (mm)						Trough Middle Section Displacement (m ³)		
	A	C	D	F	G	H	M1500	M750	M500
625	625	825	38	53	564	78	0.555	0.277	0.185
525	525	825	38	53	589	66	0.497	0.248	0.166
425	425	825	38	53	614	53	0.417	0.209	0.139
325	325	825	38	53	639	41	0.322	0.161	0.107
225	225	825	38	53	664	28	0.228	0.114	0.076

TROUGH SLAB DESIGN

Trough End dimensions and displacement values

Table 17 gives the dimensions and approximate displacement values of the Trough End sections.

Trough End sections are available in two lengths:

- Trough Glassfibre E1000 = 1000 mm long.
- Trough Glassfibre E500 = 500 mm long.

A 10% tolerance on the displacement values should be taken into consideration due to following reasons:

- Manufacturing variances.
- Repair work and imperfections due to the age of the Trough End sections.
- Temperature variations.
- Trough End movement due to rapid rate of pour.
- Deflection of the fiberglass facing due to the mass of concrete and reinforcing steel.

Note:

The diagrams in Figure 21 show the dimensions of the Trough End sections.

The dimensions given in the diagrams are approximate.

Dimension L_{1000} is for the Trough Glassfibre E1000.

Dimension L_{500} is for the Trough Glassfibre E500.

The dimensions to the curved surfaces, shown in the diagrams, are to the intersection point of the straight edges.

All 3 sides of the Trough End sections are at an 8:1 slope, or 7.13° angle.

The maximum structural topping permitted on each Glassfibre Trough is 75 mm.

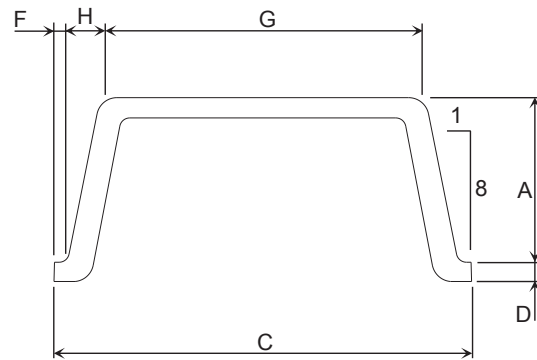

Section A - A

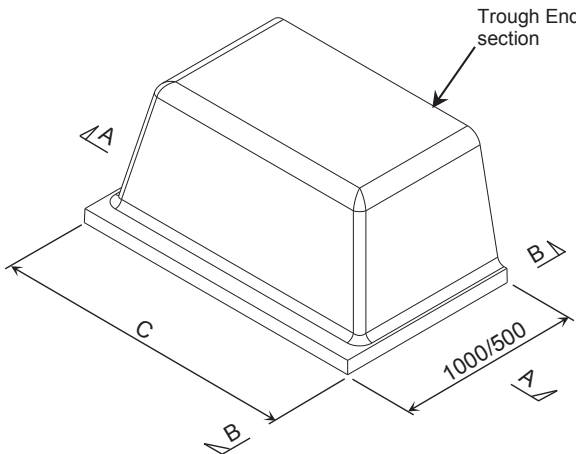

Trough End Section - 3D View

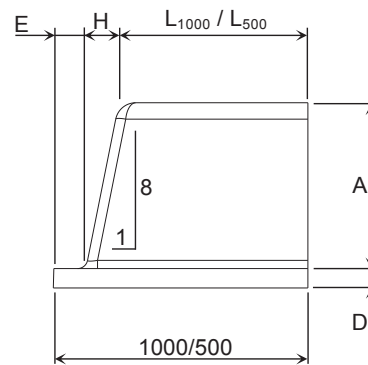

Side View B - B

Figure 21 – Side Views and 3D View Of Trough Ends

Table 17 - Trough End Dimensions And Approximate Displacement Values

Trough Size (mm)	Dimensions (mm)									Displacement (m ³)	
	A	C	D	E	F	G	H	L_{1000}	L_{500}	E1000	E500
625	625	825	38	64	53	564	78	858	358	0.318	0.133
525	525	825	38	64	53	589	66	870	370	0.288	0.122
425	425	825	38	64	53	614	53	883	383	0.245	0.106
325	325	825	38	64	53	639	41	895	395	0.191	0.083
225	225	825	38	64	53	664	28	908	408	0.136	0.060

TROUGH SLAB DESIGN

Trough slab design procedure

A Trough slab, instead of a Coffered slab, is used where the slab under consideration is a one-way spanning slab. This may be determined using any one of the following two scenarios:

Scenario 1:

The slab is only supported along 2 of the 4 edges.

Scenario 2:

The length of the longer side of the slab exceeds three times the length of the shorter side, as stated in SABS 0100-1 Ed.2.2, clause 4.4.3.

The Trough design procedure given in this Concrete Design Guide is based on a worked example, where the following assumptions have been made:

Design Example

The Trough design procedure given in this Concrete Design Guide is based on an example where the following assumptions have been made:

- The architect has requested a Trough alternative to a solid slab solution, which will be significantly lighter in weight and more economical.
- The floor slabs are to be designed for a sports facility in Johannesburg.
- The Trough slab is to be supported on 450 mm x 450 mm columns
- The imposed loads on the floor slab are based on a "sub-category B5" (Refer to SANS 10160-2, Table 1 for the different categories and specific uses).
- A concrete compressive strength of 30 MPa and a tensile reinforcing steel strength of 450 MPa is being used throughout the remainder of the building and should be used for the floor slabs where possible.
- To cater for fire resistance, the floor slabs must be designed in accordance with the SABS 0100 -1, Clause 7.

A portion of the Trough slab, described in the abovementioned example, is shown in Figure 22 below.

The worked example mainly concentrates on the design of Beam B1 and the Trough slab between Beams A1 and C1.

Other portions of the Trough slab shown in Figure 22 will only be discussed for clarification purposes as and when necessary.

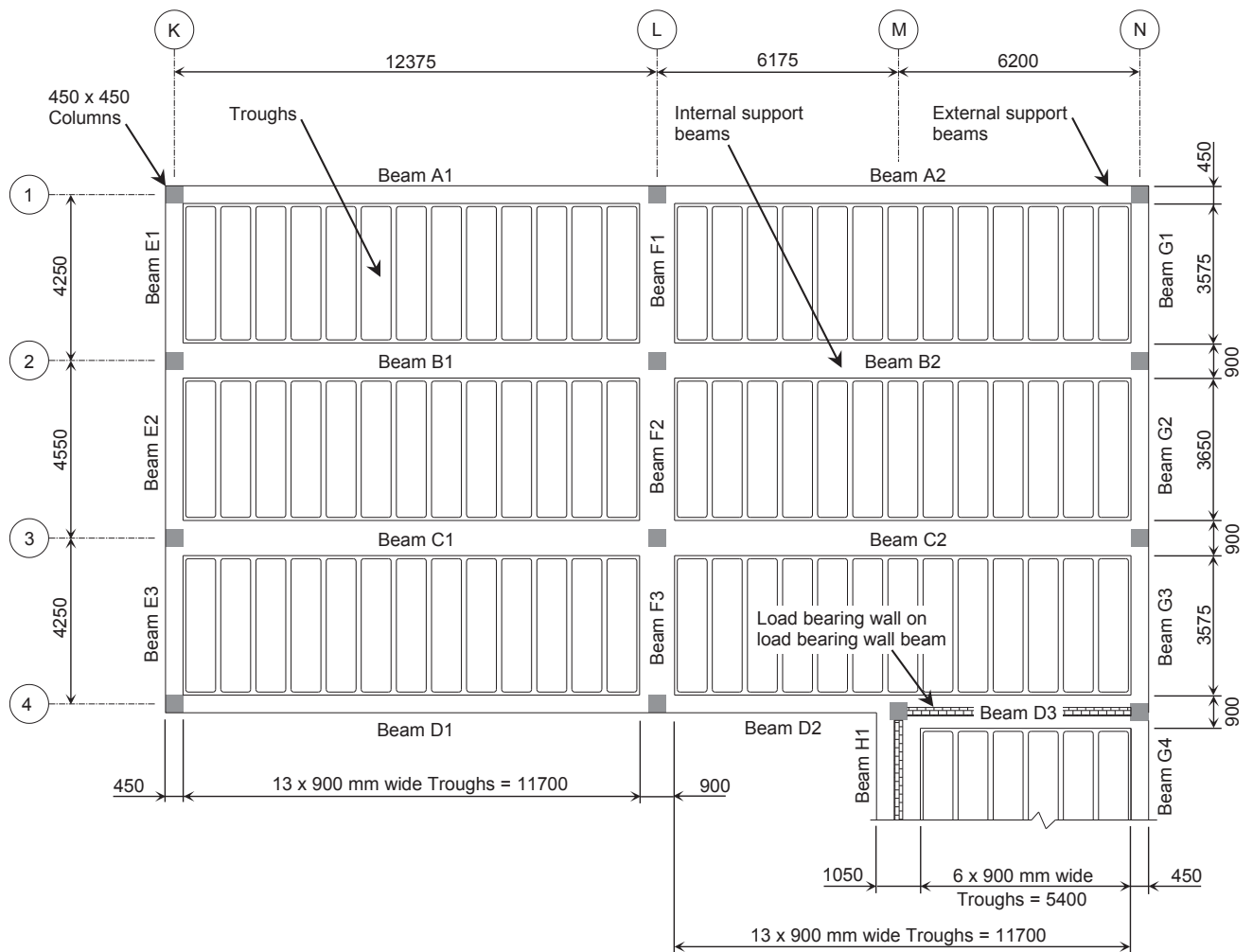

Figure 22 – Preliminary Plan Layout Of Trough Slab

TROUGH SLAB DESIGN

PART 1 – Trough and beam identification (Steps 1 to 12)

The designer is not limited to designing a Trough slab using the following Steps 1 to 50 and may use any other preferred design method.

Prior to starting with Step 1, the designer should familiarize himself/herself with the architectural drawings.

Step 1: Fill the complete deck with Troughs and internal support beams while leaving beams around the perimeter of the floor slab. Regardless of the support configuration and dimensions, the designer should start by inserting 900 mm wide concrete beams between all the internal column/wall supports as shown in Figure 22.

The width of the internal support beams can be anything from 500 mm upwards.

The designer should leave external support beams around the perimeter of the structure.

The width of these external support beams must be determined by the designer to suit the architectural and structural requirements and should initially be at least the width of the supporting columns.

The width and depth of each support beam must be verified, taking into consideration all applied dead and imposed loads.

Then, detail 900 mm wide Troughs between all the concrete beams in the short span direction (The Trough lengths of 3650 mm and 3575 mm, shown in Figure 22, will be adjusted by changing the width of the support beams as per Step 4).

It is good practice to have the Troughs line up from one slab to the other to ensure easy installation and continuity of reinforcing bars from rib to rib.

The designer may deviate from Step 1 if a different Trough layout is preferred due to other influences such as point loads on the slab.

Step 2: Identify all the load bearing walls that are supported on top of the slab.

In addition to supporting the required design loads, the designer should consider that the slab may also be required to support additional loads such as from load bearing walls on top of the slab.

Draw the load bearing walls on the layout.

Arrange all the Troughs such that there are 'load bearing wall beams' below each load bearing wall that is drawn on top of the slab (For example, Beam D3 shown in Figure 22).

Initially, allow for a 900 mm internal support beam directly below each load bearing wall.

The width and depth of each support beam may be adjusted to suit architectural and structural requirements and must be verified, taking into consideration all the applied dead and imposed loads.

Step 3: Identify the columns and beams.

For example:

The columns may be identified using the grid lines (Column K1, Column L1, etc.) as shown in Figure 22.

The support beams may be identified as shown in Figure 22.

These references identify each concrete element that is being designed and will be used when scheduling the reinforcing steel.

COFFER AND TROUGH SLAB DESIGN

TROUGH SLAB DESIGN

Step 4: Determine the Trough lengths.

Form-Scaff offers 5 different Trough sizes (Trough heights of 625 mm, 525 mm, 425 mm, 325 mm and 225 mm). Refer to Tables 16 and 17.

Table 18 gives the preferred combinations of Trough units to make up the required overall Trough lengths.

Note:

The use of the M500 Trough units is not preferred and are omitted from Table 18.

Table 18 - Preferred Trough Combinations				
Trough Length (mm)	Trough Units			
	E500	E1000	M750	M1500
1000	2	-	-	-
1500	1	1	-	-
1750	2	-	1	-
2000	-	2	-	-
2250	1	1	1	-
2500	2	-	-	1
2750	-	2	1	-
3000	1	1	-	1
3250	2	-	1	1
3500	-	2	-	1
3750	1	1	1	1
4000	2	-	-	2
4250	-	2	1	1
4500	1	1	-	2

Example:

There are many possible combinations that can be used to make up the required Trough lengths.

In addition to using Table 18, preferably contact your nearest Form-Scaff branch to find out what standard sizes are available.

From Figure 22, the preliminary Trough length required between Beam B1 and Beam C1 is 3650 mm

From Table 18, the preferred combination of (2 No. E1000 units) + (1 No. M1500 unit) = **3500 mm**

Remaining length = 3650 mm – 3500 mm = **150 mm**

The inner widths of Beams B1 and C1 must now be altered to accommodate the fixed Trough dimensions

Divide the remaining length by 2 = (150 mm ÷ 2) = **75 mm**

Then, add 75 mm to the inner side of both Beams B1 and C1

Beam B1 and C1 both have a preliminary width of 900 mm

Therefore, 900 mm + 75 mm = new beam width of 975 mm for both Beams B1 and C1

The Trough length of 3500 mm now fits between the Beams B1 and C1 (Refer to Figure 23).

From Figure 22, the preliminary Trough length required between Beam A1 and Beam B1 is 3575 mm

From Table 18, the preferred combination of (2 No. E1000 units) + (1 No. M1500 unit) = **3500 mm**

Remaining length = 3575 mm – 3500 mm = 75 mm

Assume for this example that the external Beam A1 must remain 450 mm wide

The width of the internal Beam B1 must now be altered to accommodate the fixed Trough dimensions

Add the remaining 75 mm to the side of Beam B1 (on the Beam A1 side of Beam B1)

Then, Beam A1 has a width of 450 mm and Beam B1 has a width of 975 mm + 75 mm = **1050 mm** with the 3500 mm long Troughs in between (Refer to Figure 23).

Apply the same principle to determine the widths of the Beams C1 and D1.

TROUGH SLAB DESIGN

Step 5: Draw a preliminary Trough slab layout.

Check that the concrete slab is completely filled with support beams and Troughs.

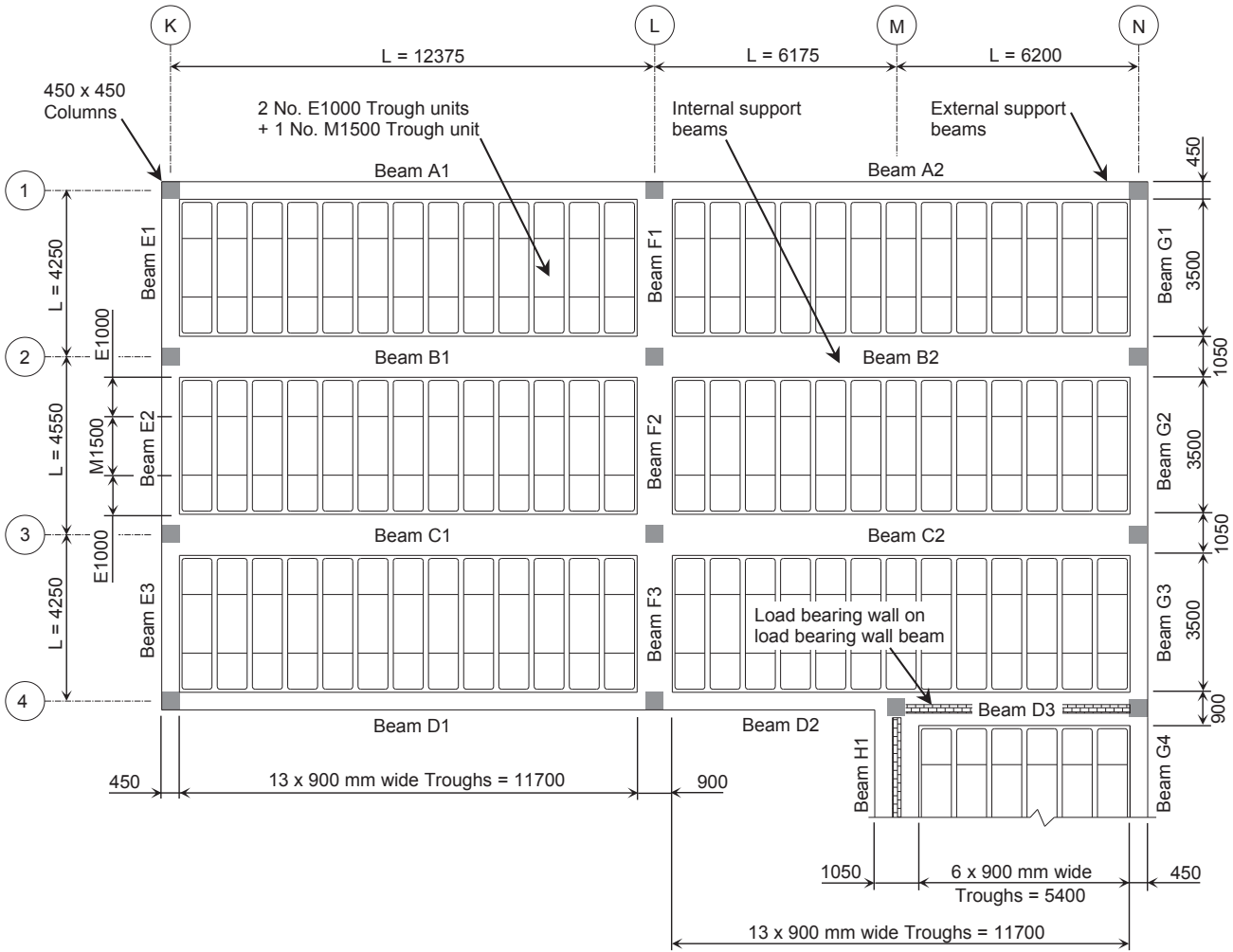

Figure 23 – Plan Layout Of Trough Slab With Adjusted Widths Of Support Beams

It is recommended that the width of the internal support beams are increased as opposed to the external support beams around the perimeter, as the internal support beams are more likely to carry larger loads.

Refer to Figure 23 for the plan layout of the Trough slab showing the adjusted widths of the internal support beams.

In some instances, if the beams are carrying small loads, it may be possible to reduce the width of the internal beams by 500 mm and then the length of the Troughs can be increased by 500 mm.

In contrast, if the beams are carrying large loads, it may be necessary to widen the internal concrete beams and reduce the overall length of the Troughs.

In most cases, the spacing does not work out exactly as per Trough and Decking Panel dimensions, thus the designer is required to move the Troughs around on the layout to try and get the supports as central as possible between two Trough configurations.

The internal beam widths should be 1500 mm, 1294 mm or 900 mm where possible to accommodate the Decking Panel sizes of 1425 mm, 1219 mm and 825 mm.

When this is not possible, infills or non-standard equipment will be required to form the soffit of the support beams which will have cost implications and increase the erection time of the falsework.

TROUGH SLAB DESIGN

Step 6: Identify the support beam with the worst-case deflection scenario based on the L/d values given in Table 4.

To determine the effective depth of the Trough slab, it is necessary to compare the different support beam configurations within the slab.

The identification of the support beam with the worst-case deflection is achieved by applying the following formula:

$$\frac{\text{Span Length 'L' (mm)}}{\text{Ratio}} = d \text{ (mm)}.$$

Where:

The Span Length 'L' is the distance between the centre lines of the supports (Refer to Figure 23).

For each beam configuration, determine the Span Length 'L' of the relevant beam (using the drawing) and select the relevant ratio from Table 4.

Example 1 (For beams not longer than 10 m):

Consider the design of support Beam B1 shown in Figure 23

Span Length 'L' = 4250 mm

Basic span/effective depth ratio from Table 4 = 24 (Beam with one end continuous)

$$'d' = \frac{\text{Span Length 'L' (mm)}}{\text{Ratio}} = \frac{4250 \text{ mm}}{24} = 177 \text{ mm}$$

Example 2 (For beams longer than 10 m):

For beams longer than 10 m, the values obtained in Table 4 should be multiplied by 10/span to prevent damages to finishes and partitions as per SABS 0100-1 Ed.2.2, clause 4.3.6.2.2.

Consider the design of support Beam B1 shown in Figure 23

Basic span/effective depth ratio from Table 4 = 24 (Beam with one end continuous)

$$'d' = \frac{\text{Span Length 'L' (mm)}}{\text{Ratio}} = \frac{12375 \text{ mm}}{24 \times (10000 \text{ mm} \div 12375 \text{ mm})} = 638 \text{ mm}$$

The largest value of 'd' will then be used to determine the slab thickness for the whole slab.

Note:

In the case of a cantilever beam, the Span Length 'L' is the distance between the centre line of the support and the end of the cantilever beam.

Step 7: Determine the required slab thickness 't' due to deflection.

The following example may be used to determine the slab thickness due to deflection:

Consider the design of support Beam B1 shown in Figure 23

Assume Y32 reinforcing bars and R16 stirrups will be used

(The actual diameter of the reinforcing bars must be checked later and be replaced if necessary, in the calculation below)

Assume the cover to reinforcement = 30 mm

(The cover must be determined in accordance with the requirements of the structure and SANS 0100-1 Ed. 2.2 Clause 4.5.7)

Required slab thickness 't' = effective depth 'd' + cover to reinforcement + half the diameter of the main reinforcing bars selected + the diameter of the stirrups (diameter_{stirrup})

$$'t' = 638 \text{ mm} + 30 \text{ mm} + (32 \text{ mm} \div 2) + 16 \text{ mm} = 700 \text{ mm}$$

Normally the slab thickness remains constant over the complete floor area, except where a definitive difference between spans or loads occur and the designer opts for a thicker or thinner slab in a specific portion due to structural or financial constraints.

TROUGH SLAB DESIGN

Step 8: Determine the Trough height and structural topping thickness.

The minimum thickness of the structural topping should be the greater of 50 mm or one-tenth of the clear span between ribs as specified in SABS 0100-01 Ed.2.2, Clause 4.5.1.2(d).

The minimum structural topping thickness for each of the Trough slab heights is illustrated in Figure 24.

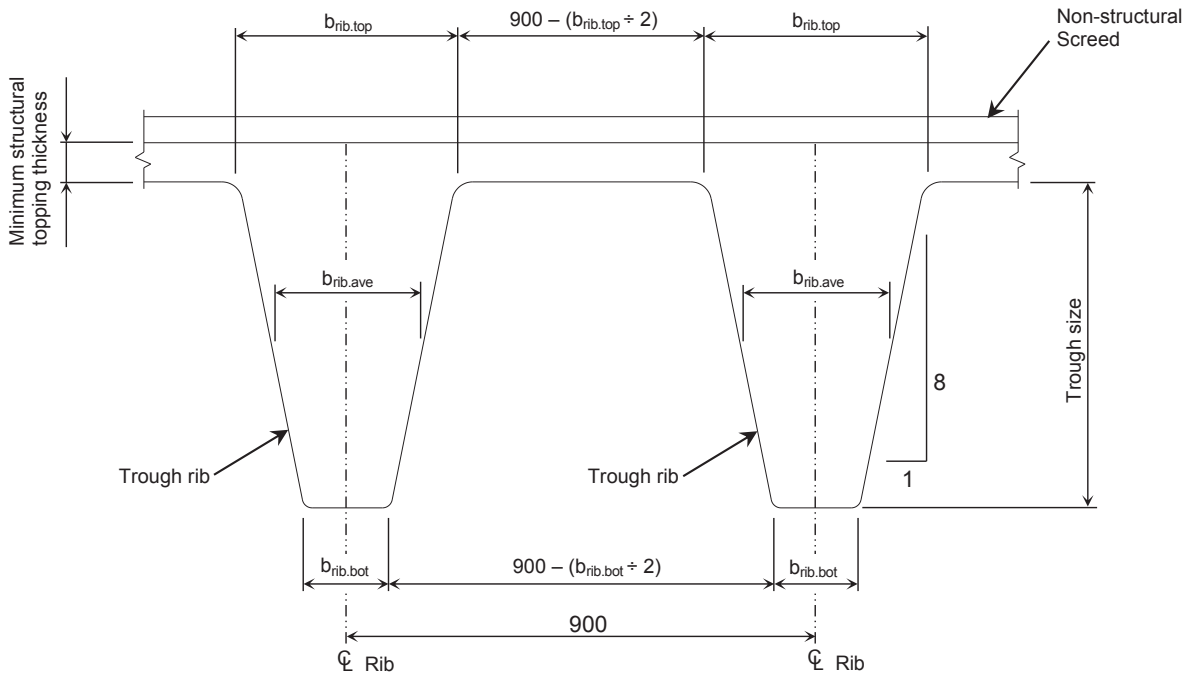

Figure 24 – Typical Trough Section

The minimum structural topping thickness for each of the Trough sizes is given in Table 19.

Table 19 - Minimum Structural Topping Thickness For Troughs Due To Deflection						
Trough Size (mm)	Clear Distance Between Ribs At Top (mm)	Clear Distance Between Ribs At Bottom (mm)	Rib Width At Top 'b _{rib.top} ' (mm)	Average Rib Width 'b _{rib.ave} ' (mm)	Rib Width At Bottom 'b _{rib.bot} ' (mm)	Minimum Structural Topping Thickness (mm)
625	564	720	336	258	180	57
525	589	720	311	246	180	59
425	614	720	286	233	180	62
325	639	720	261	221	180	64
225	663	720	237	209	180	67

The Trough height and structural topping thickness may be determined using in the following example:

Example:

Minimum slab thickness = 700 mm (From Step 7)

Trough displacement values must be extracted from Tables 16 and 17.

Plan floor area = 13 No. Troughs x 0.9 m x 3.5 m = **40.95 m²** (Number of Troughs from Figure 23).

The following scenarios may be used to determine the most economical design.

COFFER AND TROUGH SLAB DESIGN

TROUGH SLAB DESIGN

Scenario 1: (425 Troughs)

Structural topping = (700 mm slab thickness) – (425 mm Trough) = **275 mm** (Structural topping thickness > 75 mm, does not meet requirements)

Volume of concrete without Troughs = $40.95 \text{ m}^2 \times 0.700 \text{ m} = \mathbf{28.665 \text{ m}^3}$

Displacement of 13 No. 425 Troughs = $13 \times (1 \times 0.417 \text{ m}^3) + (2 \times 0.245 \text{ m}^3) = \mathbf{11.791 \text{ m}^3}$

Volume of concrete using 425 Troughs + 275 mm structural topping = **16.874 m³**

Scenario 2: (525 Troughs)

Structural topping = (700 mm slab thickness) – (525 mm Trough) = **175 mm** (Structural topping thickness > 75 mm, does not meet requirements)

Volume of concrete without Troughs = $40.95 \text{ m}^2 \times 0.700 \text{ m} = \mathbf{28.665 \text{ m}^3}$

Displacement of 13 No. 525 Troughs = $13 \times (1 \times 0.497 \text{ m}^3) + (2 \times 0.288 \text{ m}^3) = \mathbf{13.949 \text{ m}^3}$

Volume of concrete using 525 Troughs + 175 mm structural topping = **14.716 m³**

Scenario 3: (625 Troughs)

Structural topping = (700 mm slab thickness) – (625 mm Trough) = **75 mm** (Structural topping thickness \leq 75 mm, meets requirements)

Volume of concrete without Troughs = $40.95 \text{ m}^2 \times 0.700 \text{ m} = \mathbf{28.665 \text{ m}^3}$

Displacement of 13 No. 625 Troughs = $13 \times (1 \times 0.555 \text{ m}^3) + (2 \times 0.318 \text{ m}^3) = \mathbf{15.483 \text{ m}^3}$

Volume of concrete using 625 Troughs + 75 mm structural topping = **13.182 m³**

Note:

From above, it can be seen that **Scenario 3** is the most economical design.

If **Scenario 3** is used instead of a solid slab, the concrete and reinforcing will be reduced by **54.0%** in the Trough slab portions.

If a solid slab was used as opposed to a Coffers slab, the volume of concrete for a 700 mm thick flat slab = $40.95 \text{ m}^2 \times 0.700 \text{ m} = \mathbf{28.665 \text{ m}^3}$.

All the support beams are generally the same thickness as the Trough portion of the slab.

When considering the overall slab, the selection of a bigger Trough size may result in more concrete and reinforcing steel being used due to the size of all the beams and ribs.

A lighter structure means reduced reinforcement which also leads to a more economical design.

Also, consider the height restrictions when using a bigger Trough size.

Step 9: Determine the self-weight of the slab.

The designer needs to determine the self-weight of the Trough portions to determine the dead load acting on the support beams.

The assumption is made that the weight per Trough portion is directly related to the weight per square metre of Trough slab.

Example:

Trough height + structural topping = 625 mm Trough + 75 mm structural topping (From Step 8, Scenario 3)

Therefore, slab thickness 't' = $0.625 \text{ m} + 0.075 \text{ m} = \mathbf{0.700 \text{ m}}$

Plan floor area = $0.9 \text{ m} \times 3.5 \text{ m} = \mathbf{3.150 \text{ m}^2}$ per Trough

Allow for a 50 mm thick non-structural screed with the same density as concrete.

Concrete volume = $(0.700 \text{ m} + 0.050 \text{ m}) \times 3.150 \text{ m}^2 = \mathbf{2.363 \text{ m}^3}$ per Trough

Displacement for voided plan area = $((1 \text{ No. M1500}) + (2 \text{ No. E1000})) = ((1 \times 0.555 \text{ m}^3) + (2 \times 0.318 \text{ m}^3)) = \mathbf{1.191 \text{ m}^3}$ per Trough

Concrete volume = $2.363 \text{ m}^3 - 1.191 \text{ m}^3 = \mathbf{1.172 \text{ m}^3}$ per Trough

Concrete volume = $1.172 \text{ m}^3 \div 3.150 \text{ m} = \mathbf{0.372 \text{ m}^3/\text{m}^2}$ in plan

Concrete density = 25 kN/m^3 (Refer to SANS 10160-2, Table A.1)

Therefore, the self weight of the Trough portion of the slab = $0.372 \text{ m}^3/\text{m}^2 \times 25 \text{ kN/m}^3 = \mathbf{9.300 \text{ kN/m}^2}$ in plan.

TROUGH SLAB DESIGN

Step 10: Determine the self-weight of the support beam.

The designer needs to determine the self-weight of the support beam in the same manner as described in Step 9.

The only difference is that there is no deduction due to Trough displacement and the full depth of the Trough and structural topping is taken into consideration when calculating the beam depth and self-weight per m² in plan.

Example:

Minimum slab thickness 't' = 700 mm (From Step 9)

Concrete density = 25 kN/m³ (Refer to SANS 10160-2, Table A.1)

Allow for a 50 mm thick non-structural screed with the same density as concrete.

Concrete volume per support beam = (0.700 m + 0.050) x (1.0 m x 1.0 m in plan) = **0.750 m³/m²** in plan

Step 11: Determine the imposed loading acting on the slab and support beam.

The designer needs to identify the specific use for every section of the building.

Refer to SANS 10160-2, Table 1 for the different categories and specific uses.

The same building may have several different uses in different portions of the building.

An example of this is when a filing room is next to a classroom in a school.

The designer can choose to cater for the worst-case scenario throughout the building, but that may lead to an uneconomical design.

Step 12: Determine the loads acting on the slab and beam.

For the slab and support beam design, use the ultimate limit state factors as specified in SANS 10160-1, Table 3.

Permanent actions (Dead Load) such as the self-weight of the beam or slab itself, screed, tiles, etc. are multiplied by a partial factor of 1.2.

Variable actions (Live Load) such as the imposed loads acting on the floor or roof are multiplied by a partial factor of 1.6.

These are then added together to determine a design load as shown below.

$$w = 1.2 \times (\text{Sum of Dead Loads}) + 1.6 \times (\text{Sum of Live Loads})$$

Example:

Trough height + structural topping + non-structural screed = 625 mm Trough + 75 mm structural topping + 50 mm screed = 750 mm (From Step 8, Scenario 3)

Beam self-weight = 18.750 kN/m² in plan (From Step 10)

Assume that the building consists of an open sports facility, thus the imposed load = 5.0 kN/m² (Refer SANS 10160-2, Table 1)

Trough slab self-weight = 9.300 kN/m² (From Step 9)

$$w_{\text{slab}} = (1.2 \times 9.300 \text{ kN/m}^2) + (1.6 \times 5.0 \text{ kN/m}^2) = \mathbf{19.160 \text{ kN/m}^2} \text{ in plan}$$

Beam self weight = 17.500 kN/m² (From Step 10)

$$w_{\text{beam}} = (1.2 \times 18.750 \text{ kN/m}^2) + (1.6 \times 5.0 \text{ kN/m}^2) = \mathbf{30.500 \text{ kN/m}^2} \text{ in plan.}$$

COFFER AND TROUGH SLAB DESIGN

TROUGH SLAB DESIGN

PART 2 – Trough support beam design (Steps 13 to 30)

Step 13: Identify the Trough configuration acting on the support beam.

The layout for the Troughs and beams should look similar to the typical layouts shown in Figure 25.

The designer needs to isolate a beam and determine the Trough configuration associated with that specific beam.

Because the Troughs are acting as one-way spanning beams, it can be assumed that half the length of the Troughs between two support beams, act on each support or beam.

Example:

Length of Trough slab acting on Beam B1 from the Beam A1 side = $3500 \text{ mm} \div 2 = 1750 \text{ mm}$

Length of Trough slab acting on Beam B1 from the Beam C1 side = $3500 \text{ mm} \div 2 = 1750 \text{ mm}$

Therefore the total portion of Troughs acting on Beam B1 = $1750 \text{ mm} + 1750 \text{ mm} = 3500 \text{ mm}$.

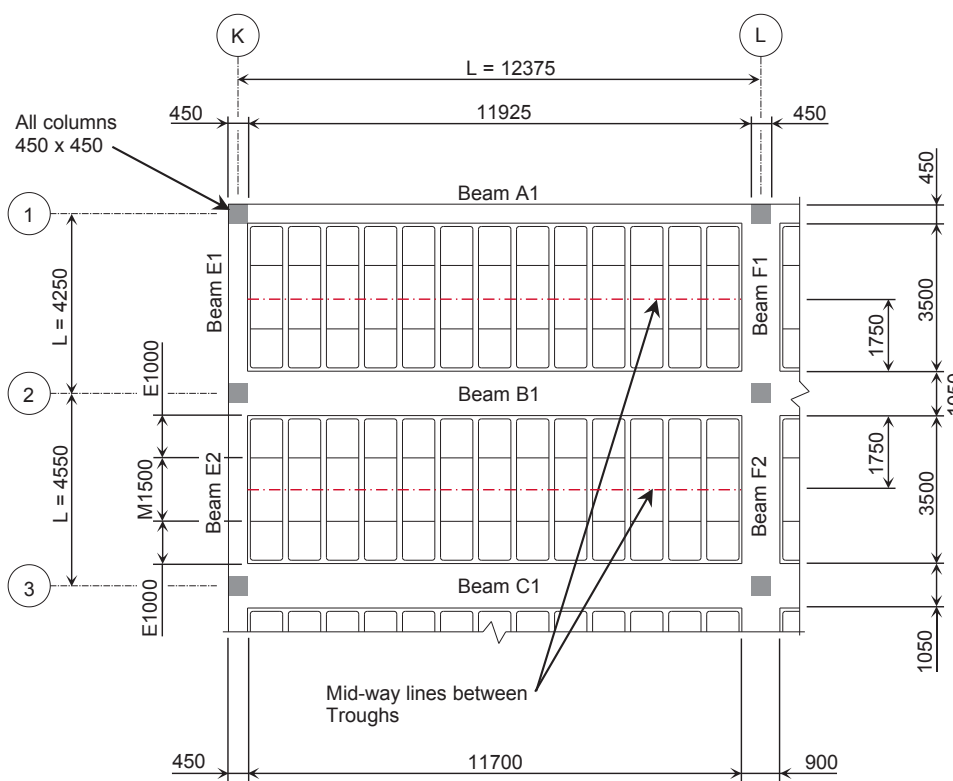

Figure 25 – Extract From Figure 23 - Plan Layout Of Trough Slab

Step 14: Determine the impact of Trough slabs acting on the support beam.

The layout for the Troughs and beams should look similar to the layout shown in Figure 25.

To determine the load acting on a beam, refer to the following example:

Example:

Refer to Beam B1 shown in Figure 25

n (Load on slab) = $w_{slab} = 19.160 \text{ kN/m}^2$ (From Step 12)

l (Length of Trough acting on Beam B1) = 3500 mm (From Step 13)

Total load from Trough slab = $19.160 \text{ kN/m}^2 \times 3.5 \text{ m} = 67.060 \text{ kN/m}$

Assume this load is uniform over the length of the beam.

TROUGH SLAB DESIGN

Step 15: Determine the total load acting on the support beam.

Calculate the total loads acting on the Beam B1.

(The loads acting on other support beams depends on the layout designed in Steps 1 to 4).

Example:

Beam B1 width 'b' = 1050 mm (From Figure 25)

$w_{\text{slab}} = 67.060 \text{ kN/m}$ (From Step 14)

$w_{\text{beam}} = 30.500 \text{ kN/m}^2$ (From Step 12)

$w_{\text{beam}} = 30.500 \text{ kN/m}^2 \times 1.050 \text{ m} = \mathbf{32.025 \text{ kN/m}}$

$w_{\text{total}} = 67.060 \text{ kN/m} + 32.025 \text{ kN/m} = \mathbf{99.085 \text{ kN/m}}$

This is the load that is used to determine the moments and area of steel required for bending.

Step 16: Determine the maximum mid-span bending moment for the beam.

There are 4 scenarios to consider if the span of the beams differ by 15% or less:

Scenario 1: Simply supported beam

$$M_{u,\text{mid}} = \frac{wl^2}{8}$$

Scenario 2: Beam continuous one end

$$M_{u,\text{mid}} = \frac{wl^2}{10}$$

Scenario 3: Beam continuous both ends

$$M_{u,\text{mid}} = \frac{wl^2}{12}$$

Scenario 4: Cantilever beam

$$M_{u,\text{mid}} = \frac{wl^2}{2}$$

If the span of the beams differ by more than 15%, a rational beam analysis should be done.

Example:

Beam B1 is continuous one end, thus Scenario 2 will be applicable

$w_{\text{total}} = 99.085 \text{ kN/m}$ (From Step 15)

Span Length 'L' = 12.375 m (From Figure 25)

Then, $M_{u,\text{mid}} = \frac{99.085 \text{ kN/m} \times (12.375 \text{ m})^2}{10} = \mathbf{1517.394 \text{ kN.m.}}$

TROUGH SLAB DESIGN

Step 17: Determine the moment of resistance for the support beam.

The effective depth for the reinforcing is required to determine the moment of resistance.

The effective depth 'd' is the depth from external face of the compression zone of the beam to the centre of the tension reinforcement as stated in SABS 0100-1 Ed.2.2, clause 4.3.3.3.

Assume that the redistribution of moments does not to exceed 10%, thus $K = 0.156$ (Refer SABS 0100-1 Ed.2.2, clause 4.3.3.4.1).

To determine the moment of resistance, apply the formula $M_r = Kbd^2f_{cu}$ (Refer SABS 0100-1 Ed.2.2, clause 4.3.3.4.1).

Example:

Beam B1 width 'b' = 1050 mm (From Figure 25)

$f_{cu} = 30$ MPa (Assumed)

After considering the relationship between the concrete mix design and the amount of reinforcing steel required, the concrete strength is to be determined by the designer.

$K = 0.156$ (Moment distribution < 10%)

$t_{beam} = 700$ mm (From Step 9)

Cover = 30 mm (From Step 7)

Tension reinforcing diameter = Y32 (Assumed)

Stirrup diameter = R16 (Assumed)

$d = t_{beam} - \text{cover} - \text{half bar diameter} - \text{diameter}_{\text{stirrup}} = 700 \text{ mm} - 30 \text{ mm} - (32 \div 2) \text{ mm} - 16 \text{ mm} = \mathbf{638 \text{ mm}}$

$M_r = Kbd^2f_{cu} = 0.156 \times 1050 \text{ mm} \times (638 \text{ mm})^2 \times 30 \text{ Mpa} = 0.156 \times 1.05 \text{ m} \times (0.638 \text{ m})^2 \times 30 \times 10^3 \text{ kN/m}^2 = \mathbf{2000.214 \text{ kN.m.}}$

TROUGH SLAB DESIGN

Step 18: Determine the area of tension reinforcing steel required for the beam at mid-span.

Check if tension reinforcing steel only is required or if both tension and compression reinforcing steel is required for the beam.

This is achieved by checking the 'K' value with the applied bending moment, where:

$$K = \frac{M_{u,\text{mid}}}{bd^2f_{cu}} \quad (\text{Refer to SABS 0100-1 Ed.2.2, clause 4.3.3.4.1})$$

If $K > 0.156$, then compression reinforcing steel is required in addition to the tension reinforcing steel.

If compression reinforcing steel is required, the designer should consider increasing the width and/or depth of the beam as it is not ideal to design for compression reinforcing steel.

If the slab depth is changed, go back to Step 7 and reassess the design.

This Concrete Design Guide does not deal with the design for compression reinforcing steel at mid-span.

Example:

$$M_{u,\text{mid}} = 1517.394 \text{ kN.m (From Step 16)}$$

$$b = 1050 \text{ mm (From Step 15)}$$

$$d = 638 \text{ mm (From Step 17)}$$

$$f_{cu} = 30 \text{ MPa (Assumed)}$$

$$K = \frac{1517.394 \text{ kN.m}}{1050 \text{ mm} \times (638 \text{ mm})^2 \times 30 \text{ MPa}} = \frac{1517.394 \text{ kN.m}}{1.050 \text{ m} \times (0.638 \text{ m})^2 \times 30 \times 10^3 \text{ kN/m}^2} = 0.118$$

$K < 0.156$, therefore only tension reinforcing steel is required

Determine the lever arm 'z'

The value of 'z' is the lesser of 0.95d and $d \times (0.5 + \sqrt{(0.25 - (K \div 0.9))})$ (Refer to SABS 0100-1 Ed.2.2, clause 4.3.3.4.1)

The required area of tension reinforcement at mid-span is determined using the following equation:

$$A_{s,\text{req}} = \frac{M_{u,\text{mid}}}{0.87f_y z}$$

The area of tension reinforcing steel should not exceed 4% of the gross cross-sectional area of the beam.

The minimum percentage of reinforcing steel for a rectangular beam is given in Table 6.

Determine the area of reinforcing steel required for the beam

$$M_{u,\text{mid}} = 1517.394 \text{ kN.m (From Step 16)}$$

$f_y = 450 \text{ MPa}$ for hot-rolled high-yield steel (Refer to SABS 0100-1 Ed.2.2, Table 3)

$$d = 638 \text{ mm (From Step 17)}$$

$$z = \text{lesser of } 0.95 \times 638 \text{ mm} = 606 \text{ mm and } 638 \times (0.5 + \sqrt{(0.25 - (0.118 \div 0.9))}) = 539 \text{ mm}$$

$$A_{s,\text{req}} = \frac{M_{u,\text{mid}}}{0.87f_y z} = \frac{1517.394 \text{ kN.m}}{0.87 \times 450 \text{ MPa} \times 539 \text{ mm}} = \frac{1517.394 \times 10^3 \text{ kN.mm}}{0.87 \times 450 \times 10^{-3} \text{ kN/mm}^2 \times 539 \text{ mm}} = 7191 \text{ mm}^2$$

Beam B1 width 'b' = 1050 mm (From Step 15)

$$t_{\text{beam}} = 700 \text{ mm (From Step 9)}$$

$$A_c = b \times t_{\text{beam}} = 1050 \text{ mm} \times 700 \text{ mm} = 735.0 \times 10^3 \text{ mm}^2$$

$$A_{s,\text{min}} = 0.13 \text{ (From Table 6)} \times (A_c \div 100) = 0.13 \times (735.0 \times 10^3 \text{ mm}^2 \div 100) = 955.5 \text{ mm}^2$$

$$A_{s,\text{max}} = 4\% \times (b \times t_{\text{beam}}) = 0.04 \times (735.0 \times 10^3 \text{ mm}^2) = 29.4 \times 10^3 \text{ mm}^2$$

$$A_{s,\text{min}} < A_{s,\text{req}} < A_{s,\text{max}} \text{ therefore } A_{s,\text{req}} = 7191 \text{ mm}^2.$$

TROUGH SLAB DESIGN

Step 19: Select the spacing and type of tension reinforcing steel to be used for mid-span bending.

Determine the diameter and spacing of the of the tension reinforcing bars.

For this example, assume a spacing of 170 mm (At this stage, the designer must assume the spacing of the reinforcing bars).

The assumed spacing is then used to determine the number of reinforcing bars that will fit across the width of the support beam.

After the number of reinforcing bars is determined, the actual spacing can be calculated.

The required cross-sectional area per reinforcing bar can be determined by dividing the total reinforcing steel area required ($A_{s,req}$) by the number of reinforcing bars provided.

This cross-sectional area must be compared to the values given in Table 7 to determine the reinforcing bar diameter that will meet the minimum cross-sectional area requirements.

First, check that the assumed and calculated spacing of the reinforcing bars is smaller than the maximum spacing allowed for the specific section

by calculating the service stress $f_s = 0.87f_y \times \frac{y_1 + y_2}{y_3 + y_4} \times \frac{A_{s,req}}{A_{s,prov}} \times \frac{1}{\beta_b}$ (Refer to SABS 0100-1 Ed.2.2, clause 4.3.6.3.1)

Where:

y_1 = self-weight load factor for serviceability limit states = 1.1

y_2 = imposed load factor for serviceability limit states = 1.0

y_3 = self-weight load factor for ultimate limit states = 1.2

y_4 = imposed load factor for ultimate limit states = 1.6

β_b = ratio of resistance moment at mid-span obtained from the redistributed maximum moments diagram to that obtained from the maximum moments diagram before redistribution = 1.0

(Refer to SABS 0100-1 Ed.2.2, clause 4.3.6.3.1; SANS 10160-1, Table 3, and SANS 10160-1, clause 8.3.1.1)

Then, check that the maximum reinforcing bar spacing is the smaller of 300 mm or $47000 \div f_s$ (Refer to SABS 0100-1 Ed.2.2, clause 4.11.8.2.1.4).

Example:

Beam B1 width 'b' = 1050 mm (From step 15)

Spacing of reinforcing bars = 170 mm (Assumed)

f_y = 450 MPa = 450 N/mm² (From Step 18)

$A_{s,req}$ = 7191 mm² (From Step 18)

Number of reinforcing bars = $b - (2 \times \text{cover}) \div \text{spacing} + 1 \text{ bar} = 1050 \text{ mm} - (2 \times 30 \text{ mm}) \div 170 \text{ mm} = 5.8 \text{ bars} + 1 \text{ bar} = 6.8$ rounded up to **7 bars**

Actual spacing = $b - (2 \times \text{cover}) \div (\text{number of bars} - 1 \text{ bar}) = 1050 \text{ mm} - (2 \times 30 \text{ mm}) \div (7 - 1) = 165 \text{ mm}$ rounded down to **160 mm**

Required cross-sectional area per reinforcing bar = $A_{s,req} \div \text{number of reinforcing bars} = 7191 \text{ mm}^2 \div 7 = \mathbf{1027 \text{ mm}^2}$ per reinforcing bar

From Table 7 it can be seen that 1 No. Y32 reinforcing bar has a cross sectional area of 804 mm² which is less than the required cross-sectional area of 1027 mm² per reinforcing bar

Therefore increase the number of Y32 reinforcing bars to 9 No.

The total area $A_{s,prov} = 9 \text{ No.} \times 804 \text{ mm}^2 = 7236 \text{ mm}^2$, which is greater than 7191 mm², therefore reinforcing steel is okay.

The service stress $f_s = 0.87(450 \text{ N/mm}^2) \times \frac{1.1 + 1.0}{1.2 + 1.6} \times \frac{7191 \text{ mm}^2}{7236 \text{ mm}^2} \times \frac{1}{1.0} = \mathbf{292 \text{ N/mm}^2}$

Check that the maximum reinforcing bar spacing is the smaller of 300 mm or $47000 \div f_s$ (Refer to SABS 0100-1 Ed.2.2, clause 4.11.8.2.1.4)

$47000 \div f_s = 47000 \div 292 \text{ N/mm}^2 = \mathbf{161 \text{ mm}}$

Actual spacing = $b - (2 \times \text{cover}) \div (\text{number of bars} - 1 \text{ bar}) = 1050 \text{ mm} - (2 \times 30 \text{ mm}) \div (9 - 1) = 124 \text{ mm}$ rounded down to 120 mm

Spacing of 120 mm is less than the maximum spacing of 161 mm

Therefore, to cater for the bending moment, use **9 No. Y32** reinforcing bars at a spacing of **120 mm**.

The designer can choose a larger spacing than the spacing calculated above and re-check the diameter of the reinforcing bars required.

To determine the most economical reinforcing steel, it all depends on the maximum spacing allowed for specific diameters of reinforcing bars.

TROUGH SLAB DESIGN

Step 20: Determining the required number of stirrups.

The number of stirrups is determined based on the number of longitudinal tension reinforcing bars present in the support beam under consideration.

It is good practice to have longitudinal bars in the corner of a stirrup.

Each stirrup has 2 vertical legs which provides a position in each corner for 1 main longitudinal bar.

The number of bars in the beam is divided by 2 to determine the number of stirrups.

If the total number of main longitudinal tension bars is an uneven number, 1 No. tension bar runs in the middle of the beam without being in the corner of a stirrup.

Example:

Tension reinforcing steel = 9 No. Y32 bars at a spacing of 120 mm (From Step 19)

Beam B1 width 'b' = 1050 mm (From Figure 25)

Number of stirrups = $9 \text{ No. Y32} \div 2 \text{ tension bars per stirrup} = 4.5 \text{ No. stirrups}$ rounded down to 4 No. stirrups type A, B, C and D (Refer to Figure 26)

The designer may choose any preferred stirrup shape and configuration to suit the main reinforcing steel, provided that the minimum requirement for shear is met

Two typical examples of stirrup arrangements are shown in Figure 26

Due to the congestion of the hooks at the top of the stirrups in Example 2, the stirrup configuration in Example 1 may be preferred.

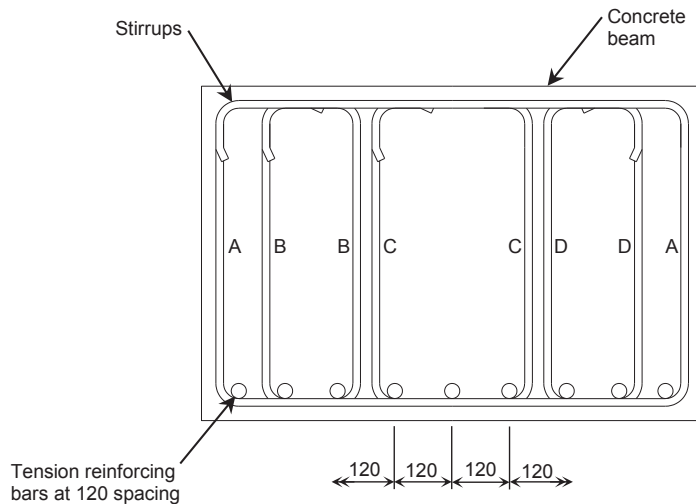

Example 1

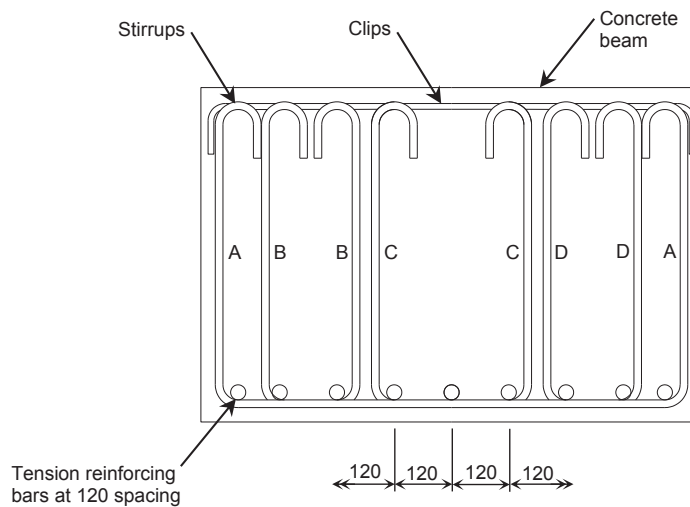

Example 2

Figure 26 – Typical Cross Sections Showing Stirrup Arrangements

TROUGH SLAB DESIGN

Step 21: Checking the shear resistance of a beam.

The design shear force, due to the design maximum loads for the ultimate limit state, must be determined.

To simplify, conservatively assume that the beams are simply supported to determine the reaction forces at each support.

To check the maximum shear strength of a beam, the reaction forces at the internal support must be determined.

If both supports are under continuous beams, both supports must be analysed and the worst case shear force is used in the design calculations.

The design shear stress 'v' at any cross-section of the beam should not exceed a value of the lesser of $\sqrt{f_{cu}}$ or 4.75 MPa. (Refer to SABS 0100-1 Ed.2.2, clause 4.3.4.1.1)

Design shear stress $v = \frac{V}{bd}$ (Refer to SABS 0100-1 Ed.2.2, clause 4.3.4.1.1)

Maximum design shear stress of concrete $v_c = \frac{0.75}{\gamma_m} \left(\frac{f_{cu}}{25}\right)^{1/3} \left(\frac{100A_s}{b_v d}\right)^{1/3} \left(\frac{400}{d}\right)^{1/4}$ (Refer to SABS 0100-1 Ed.2.2, clause 4.3.4.1.2)

In the above equation, it is generally accepted that the value of 0.75 may be increased to 0.79 for design purposes.

The value of 0.75 is used throughout in this Concrete Design Guide.

In the above equation, it is recommended that the value of 0.75 is increased to 0.79 for design purposes

Where $\left(\frac{100A_s}{b_v d}\right)$ should not be taken as greater than 3 (refer SABS 0100-1 Ed.2.2, clause 4.3.4.1.2)

The design shear stress must be less than the maximum design shear stress, if not, either additional shear reinforcement must be added or the cross-section of the beam should be altered.

To determine the required ratio of shear reinforcement to rebar spacing, apply the following equation:

$$\frac{A_{sv}}{S_v} \geq \frac{b(v - v_c)}{0.87f_{yv}}$$

Where:

A_{sv} is the cross-sectional area of the two legs of a stirrup

f_{yv} is the characteristic strength of the stirrup reinforcement (R16 = 250 MPa = 250 N/mm²)
(Refer to SABS 0100-1 Ed.2.2, clause 4.3.4.1.3)

Example:

$w = 99.085$ kN/m (From Step 15)

Span length 'L' = 12375 mm (From Step 6)

Then, design shear force $V = \frac{wl}{2} = \frac{99.085 \text{ kN/m} \times 12375 \text{ mm}}{2} = \frac{99.085 \text{ kN/m} \times 12.375 \text{ m}}{2} = 613.088$ kN (At external support)

Design shear force $V = 2 \times 613.088$ kN = **1226.176** kN, assuming that lengths are the same on either side of the internal support.

The designer should do a proper beam analysis to determine the reaction forces on each support, preferably using a specialist software package

Beam B1 width 'b' = 1050 mm (From Figure 25)

$d = 638$ mm (From Step 17)

Design shear stress $v = \frac{V}{bd} = \frac{1226.176 \text{ kN}}{1050 \text{ mm} \times 638 \text{ mm}} = \frac{1226.176 \times 10^3 \text{ N}}{1050 \text{ mm} \times 638 \text{ mm}} = 1.830$ N/mm² = **1.830** MPa

$f_{cu} = 30$ MPa = 30 N/mm² (From Step 17)

Maximum shear stress $v_{max} = \text{smaller of } 0.75\sqrt{30} = 4.108$ MPa and **4.75** MPa

$v < v_{max}$ therefore okay

$A_{s,prov} = 7236.0$ mm² (From Step 19)

$\frac{100A_s}{b_v d} = \frac{100 \times 7236.0 \text{ mm}^2}{1050 \text{ mm} \times 638 \text{ mm}} = 1.080 < 3$, therefore okay

Partial safety factor for materials for shear strength without shear reinforcement and shear taken by concrete in combination with shear reinforcement $\gamma_m = 1.40$ (Refer to SABS 0100-1 Ed.2.2, clause 3.3.3.2)

TROUGH SLAB DESIGN

$$v_c = \frac{0.75}{1.4} \left(\frac{30 \text{ N/mm}^2}{25} \right)^{1/3} (1.080)^{1/3} \left(\frac{400}{638 \text{ mm}} \right)^{1/4} = 0.520 \text{ N/mm}^2 = \mathbf{0.520 \text{ MPa}}$$

$v > v_c$ therefore additional shear reinforcement must be designed.

To determine the required ratio of shear reinforcement to the reinforcing bar spacing, apply the following equation:

$$\frac{A_{sv}}{s_v} \geq \frac{b(v - v_c)}{0.87f_{yv}}$$

$$\frac{A_{sv}}{s_v} \geq \frac{1050 \text{ mm} (1.830 \text{ N/mm}^2 - 0.520 \text{ N/mm}^2)}{0.87 \times 250 \text{ N/mm}^2} = \mathbf{6.324} \text{ (This ratio will be used in Step 22 to determine the spacing of the stirrups).}$$

Step 22: Determine the spacing of stirrups.

s_v is the spacing of the stirrups along a beam.

The spacing should not exceed 0.75 times the effective depth of the reinforcement.

The initial assumption is made that the spacing of the stirrups is just below 0.75 times the effective depth of the reinforcing steel.

If the assumed spacing of the stirrups is found to be insufficient, the spacing must be reduced accordingly.

If the following equation is true, then the spacing is okay, if not, reduce the spacing:

$$\frac{A_{sv}}{s_v} \geq \frac{b(v - v_c)}{0.87f_{yv}}$$

Where:

A_{sv} = the cross-sectional area of the two legs of a stirrup

f_{yv} = the characteristic shear strength of the link reinforcement (R16 = 250 MPa)

Example:

$d = 638 \text{ mm}$ (From Step 17)

$S_{v,max} = 0.75d = 0.75 \times 638 \text{ mm} = \mathbf{479 \text{ mm}}$

$s_v = 450 \text{ mm}$ (Assumed stirrup spacing)

$s_v < S_{v,max}$ therefore okay

Number of R16 stirrups = 4 No. (From Step 20)

Therefore the number of legs = 4 No. x 2 legs per stirrup = **8 No.**

R16 cross-sectional area = 201 mm² (Refer to Table 7)

$iA_{sv,prov} = 8 \text{ No.} \times 201 \text{ mm}^2 = \mathbf{1608 \text{ mm}^2}$

$$\frac{A_{sv}}{s_v} = 6.324 \text{ (From Step 21)}$$

$A_{sv,req} = 6.324 \times 450 \text{ mm spacing} = \mathbf{2845 \text{ mm}^2}$

$A_{sv,prov} < A_{sv,req}$ therefore not okay.

$$S_{v,max} = \frac{A_{sv,prov}}{(A_{sv} \div s_v)} = \frac{1608 \text{ mm}^2}{6.324} = 254.3 \text{ mm} = \mathbf{250 \text{ mm}} \text{ rounded down}$$

New $A_{sv,req} = 6.324 \times 250 \text{ mm} = \mathbf{1581 \text{ mm}^2}$

$A_{sv,prov} > A_{sv,req}$ therefore okay

Provide 4 No. R16 stirrups at 250 mm spacing along the full length of the beam as per Figure 28.

TROUGH SLAB DESIGN

Step 23: Determine the maximum support bending moment for the beam.

There are 4 scenarios to consider if the span of the beams differ by 15% or less:

Scenario 1:

External support on continuous beam

$$M_{u,\text{sup}} = 0$$

Scenario 2:

1st Internal support on continuous beam

$$M_{u,\text{sup}} = - \frac{wl^2}{9}$$

Scenario 3:

2nd Internal support on continuous beam

$$M_{u,\text{mid}} = - \frac{wl^2}{12}$$

Scenario 4:

Simply supported beam

$$M_{u,\text{mid}} = 0$$

If the span of the beams differ by more than 15%, a rational beam analysis should be done.

Example:

Beam is continuous one end only (Determined from the layout drawing, refer to Figure 25)

Scenarios 1 and 2 are both applicable, but since the moment on the external support is 0, for this example, only design for the 1st internal support on the continuous beam (Scenario 2)

$w = 99.085 \text{ kN/m}$ (From Step 15)

Span Length 'L' = 12375 mm = 12.375 m (From Figure 25)

Calculate the maximum support bending moment for Beam B1:

$$M_{u,\text{sup}} = - \frac{wl^2}{9} = \frac{99.085 \times (12.375 \text{ m})^2}{9} = - \mathbf{1685.993 \text{ kN.m.}}$$

TROUGH SLAB DESIGN

Step 24: Determine the area of tension reinforcing steel required for the beam at the support.

Check if only tension reinforcement is required for the beam or if compression reinforcement is also required.

This is done by checking the 'K' value with the applied bending moment, where:

$$K = \frac{M_{u,\text{sup}}}{bd^2f_{cu}} \quad (\text{Refer to SABS 0100-1 Ed.2.2, clause 4.3.3.4.1})$$

If $K > 0.156$, then compression reinforcement is required in addition to the tension reinforcement.

If this is the case, the designer should increase the width of the beam as it is not ideal to design for compression reinforcement.

This Design Guide will not discuss the design for compression reinforcement at mid-span.

Example:

Beam B1 width 'b' = 1050 mm (From Step 15)

$M_{u,\text{sup}} = -1685.993$ kN.m (From Step 23)

$d = 638$ mm (From Step 17)

$f_{cu} = 30$ MPa (From Step 17)

$$K = \frac{1685.993 \text{ kN.m}}{1050 \text{ mm} \times (638 \text{ mm})^2 \times 30 \text{ MPa}} = \frac{1685.993 \text{ kN.m}}{1.050 \text{ m} \times (0.638 \text{ m})^2 \times 30 \times 10^3 \text{ kN/m}^2} = 0.131$$

Thus $K < 0.156$, therefore only tension reinforcement is required

Determine the lever arm 'z'

The value of 'z' is the lesser of $0.95d$ and $d \times (0.5 + \sqrt{(0.25 - (K \div 0.9))})$ (Refer to SABS 0100-1 Ed.2.2, clause 4.3.3.4.1)

The required area of tension reinforcement is determined using the following equation:

$$A_{s,\text{req}} = \frac{M_{u,\text{sup}}}{0.87f_y z}$$

The area of tension reinforcing steel should not exceed 4% of the gross cross-sectional area of the beam.

The minimum percentage of reinforcing steel for a rectangular beam is given in Table 6.

Example:

$M_{u,\text{sup}} = -1685.993$ kN.m (From Step 23)

$f_y = 450$ MPa for hot-rolled high-yield steel (Refer to SABS 0100-1 Ed.2.2, Table 3)

$d = 638$ mm (From Step 17)

$z = \text{lesser of } 0.95 \times 638 \text{ mm} = 360 \text{ mm} \text{ and } 638 \times (0.5 + \sqrt{(0.25 - (0.131 \div 0.9))}) = 525 \text{ mm}$

$$A_{s,\text{req}} = \frac{1685.993 \text{ kN.m}}{0.87 \times 450 \text{ MPa} \times 525 \text{ mm}} = \frac{1685.993 \times 10^3 \text{ kN.mm}}{0.87 \times 450 \times 10^{-3} \text{ kN/mm}^2 \times 525 \text{ mm}} = 8203 \text{ mm}^2$$

Beam B1 width 'b' = 1050 mm (From Step 15)

$t_{\text{beam}} = 700$ mm (From Step 9)

$A_c = b \times t_{\text{beam}} = 1050 \text{ mm} \times 700 \text{ mm} = 735.0 \times 10^3 \text{ mm}^2$

$A_{s,\text{min}} = 0.13 \times A_c \div 100 = 0.13 \times 735.0 \times 10^3 \div 100 = 956 \text{ mm}^2$

$A_{s,\text{max}} = 4\% \times (b \times t_{\text{beam}}) = 0.04 \times (1050 \text{ mm} \times 700 \text{ mm}) = 29.4 \times 10^3 \text{ mm}^2$

$A_{s,\text{max}} > A_{s,\text{req}} > A_{s,\text{min}}$ therefore $A_{s,\text{req}} = 8203 \text{ mm}^2$.

TROUGH SLAB DESIGN

Step 25: Select the spacing and type of tensile reinforcing steel to be used for support bending.

The diameter and spacing of the reinforcing bars must now be determined.

The designer can assume the spacing and number of reinforcing bars to be the same as the spacing for the reinforcement at mid-span as determined in Step 19 to simplify the fixing of the reinforcing bars.

The required cross-sectional area of each reinforcing bar ($A_{s,req}$) can be determined by dividing the total required area of reinforcement by the number of reinforcing bars provided.

To meet the minimum cross-sectional area requirements, this cross-sectional area must be compared to the values given in Table 7 to determine the diameter of the reinforcing bar required.

First, check that the assumed and calculated spacing of the reinforcing bars is smaller than the maximum spacing allowed for the specific section by

calculating the service stress $f_s = 0.87f_y \times \frac{y_1 + y_2}{y_3 + y_4} \times \frac{A_{s,req}}{A_{s,prov}} \times \frac{1}{\beta_b}$ (Refer to SABS 0100-1 Ed.2.2, clause 4.3.6.3.1)

Where:

y_1 = self-weight load factor for serviceability limit states = 1.1

y_2 = imposed load factor for serviceability limit states = 1.0

y_3 = self-weight load factor for ultimate limit states = 1.2

y_4 = imposed load factor for ultimate limit states = 1.6

β_b = ratio of resistance moment at mid-span obtained from the redistributed maximum moments diagram to that obtained from the maximum moments diagram before redistribution = 1.0

(Refer to SABS 0100-1 Ed.2.2, clause 4.3.6.3.1; SANS 10160-1, Table 3, and SANS 10160-1, clause 8.3.1.1)

Then, check that the maximum reinforcing bar spacing is the smaller of 300 mm or $47000 \div f_s$ (Refer to SABS 0100-1 Ed.2.2, clause 4.11.8.2.1.4).

Example:

Beam width $b = 1050$ mm (From step 15)

Spacing of reinforcing bars = 120 mm (From Step 19)

$f_y = 450$ MPa = 450 N/mm² (From Step 18)

$A_{s,req} = 8203$ mm² (From Step 24)

Number of reinforcing bars = 9 No. Y32 (From Step 19)

Required cross-sectional area per reinforcing bar = $A_{s,req} \div \text{number of reinforcing bars} = 8203 \text{ mm}^2 \div 9 = \mathbf{912}$ mm² per reinforcing bar

From Table 7, a Y32 reinforcing bar has a smaller cross-sectional area (804 mm²) than the required reinforcing bar area of 912 mm²

Increase the number of bars to increase the cross-sectional area of reinforcing steel to 9 No. Y32 bars plus 2 No. Y25 bars.

Bundle each outer Y32 reinforcing bar with 1 No. Y25 bar.

The total area $A_{s,prov} = (9 \text{ No. bars} \times 804 \text{ mm}^2) + (2 \text{ No. bar} \times 491 \text{ mm}^2) = \mathbf{8218}$ mm² which is greater than 8203 mm², therefore reinforcing steel is okay

The service stress $f_s = 0.87(450 \text{ N/mm}^2) \times \frac{1.1 + 1.0}{1.2 + 1.6} \times \frac{8203 \text{ mm}^2}{8218 \text{ mm}^2} \times \frac{1}{1.0} = \mathbf{293}$ N/mm²

Check that the maximum reinforcing bar spacing is the smaller of 300 mm or $47000 \div f_s$

$47000 \div f_s = 47000 \div 293 \text{ N/mm}^2 = \mathbf{160}$ mm

The spacing of 120 mm is smaller than the maximum spacing of 160 mm

Therefore, to cater for the moment, use **9** No. Y32 bars at a spacing of 120 mm plus **2** No. Y25 bundled bars (Refer to Figure 29).

The designer can choose a different spacing than the spacing calculated above and re-check the diameter of the reinforcing bars required.

To determine the most economical reinforcing steel, it all depends on the maximum spacing allowed for specific diameters of reinforcing bars.

TROUGH SLAB DESIGN

Step 26: Check the deflections based on the basic allowable span.

To prevent damage to finishes and partitions for beams with spans up to 10 m, the deflection must be limited to span divided by 250.

The basic span/effective depth ratios are given in Table 4.

Serviceability Limit State Load = 1.1DL + 1.0LL (Refer to SANS 10160-1, clause 8.3.1.1).

The basic span/effective depth ratio value obtained from Table 4 must be modified with a modification factor that takes into account the amount of tension reinforcement and the associated stresses when the allowable span/effective depth ratio is calculated.

The modification factor is derived from the following equation:

$$\text{Modification factor} = 0.55 + \frac{477 - f_s}{120 \left(0.9 + \frac{M_u}{bd^2} \right)} \leq 2.0 \quad (\text{Refer to SABS 0100-1 Ed.2.2, clause 4.3.6.3.1})$$

The allowable span/effective depth ratio will then be the basic span/effective depth ratio multiplied by the calculated modification factor.

The actual span/effective depth ratio can now be calculated using the beam layout shown in Figure 25.

If the actual span/effective depth ratio is bigger than the allowable span/effective depth ratio, the beam fails due to deflection.

Example:

Assume end span condition = continuous one end only (Beam B1 from Figure 25)

Determine the serviceability load:

Where:

$$DL_{\text{beam}} = 18.750 \text{ kN/m}^2 \times 1.050 \text{ m wide} = \mathbf{19.688 \text{ kN/m}} \quad (\text{From Step 10})$$

$$LL_{\text{beam}} = 5.0 \text{ kN/m}^2 \times 1.050 \text{ m wide} = \mathbf{5.250 \text{ kN/m}} \quad (\text{From Step 12})$$

$$\text{Beam load} = (1.1 \times 19.688 \text{ kN/m}) + (1.0 \times 5.250 \text{ kN/m}) = \mathbf{26.907 \text{ kN/m}}$$

$$l = \text{length of Trough acting on Beam B1} = 3500 \text{ mm} \quad (\text{From Step 13})$$

$$DL_{\text{slab}} = 9.300 \text{ kN/m}^2 \times 3.5 \text{ m} = \mathbf{32.550 \text{ kN/m}} \quad (\text{From Step 9})$$

$$LL_{\text{slab}} = 5.0 \text{ kN/m}^2 \times 3.5 \text{ m} = \mathbf{17.500 \text{ kN/m}} \quad (\text{From Step 12})$$

$$\text{Slab Load } w = (1.1 \times 32.550 \text{ kN/m}) + (1.0 \times 17.500 \text{ kN/m}) = \mathbf{53.305 \text{ kN/m}}$$

$$\text{Total serviceability load } w = 26.907 \text{ kN/m} + 53.305 \text{ kN/m} = \mathbf{80.212 \text{ kN/m}}$$

Calculate the service stress:

Where:

$$A_{s,\text{req}} = 7191 \text{ mm}^2 \quad (\text{From Step 18})$$

$$A_{s,\text{prov}} = 7236.0 \text{ mm}^2 \quad (\text{From Step 19})$$

$$\text{Total ultimate load } w_{\text{total}} = 99.085 \text{ kN/m} \quad (\text{From Step 15})$$

$$\text{Service stress} = 0.87(450 \text{ MPa}) \times \frac{80.212 \text{ kN/m}}{99.085 \text{ kN/m}} \times \frac{7191 \text{ mm}^2}{7236 \text{ mm}^2} \times \frac{1}{1} = 0.87(450 \text{ N/mm}^2) \times \frac{80.212 \times 10^6 \text{ N/mm}}{99.085 \times 10^6 \text{ N/mm}} \times \frac{7191 \text{ mm}^2}{7236 \text{ mm}^2} \times \frac{1}{1} = \mathbf{315 \text{ N/mm}^2}$$

Calculate the modification factor:

Where:

$$M_u = 1517.394 \text{ kN.m} = 1517.394 \times 10^6 \text{ N.mm} \quad (\text{From Step 16})$$

$$\text{Beam B1 width 'b'} = 1050 \text{ mm} \quad (\text{From Step 15})$$

$$d = 638 \text{ mm} \quad (\text{From Step 17})$$

$$\text{Modification factor} = 0.55 + \frac{477 - f_s}{120 \left(0.9 + \frac{M_u}{bd^2} \right)} = 0.55 + \frac{477 \text{ N/mm}^2 - 315 \text{ N/mm}^2}{120 \left(0.9 \text{ N/mm}^2 + \frac{1517.394 \times 10^6 \text{ N.m}}{1050 \text{ mm} \times (638 \text{ mm})^2} \right)} = \mathbf{0.853}$$

The modification factor of 0.853 is smaller than 2.0, therefore take the modification factor as 0.853

Allowable span/effective depth ratio = (Modification factor) x (Basic span/effective depth ratio)

Where:

$$\text{Basic span/effective depth ratio} = 24 \quad (\text{From Table 4})$$

$$(\text{Modification factor}) \times (\text{Basic span/effective depth ratio}) = 0.853 \times 24 = \mathbf{20.472}$$

$$\text{Span length 'L'} = 12375 \text{ mm} \quad (\text{From Step 6})$$

TROUGH SLAB DESIGN

Actual span ÷ effective depth = 12375 mm ÷ 638 mm = **19.397**

19.397 < 20.472 therefore the beam is okay. (Increase the beam width or depth if the actual > allowable)

Step 27: Calculate the actual long-term deflections of the support beams.

The designer needs to determine the Moment of Inertia for the cross-sectional area of the concrete beam.

This is done by taking the width and the thickness of the beam into consideration using the following formula:

$$I_x = \frac{bh^3}{12}$$

The short-term modulus of elasticity for the specified strength of the concrete can be determined from Table 8.

For long term deflections, a conservative assumption is that the modulus of elasticity is only half the value given in Table 8.

Long term deflections can then be determined using one of the following equations:

$$\text{Truly simply supported beam } \delta = \frac{5wl^4}{384E_cI_x}$$

$$\text{Beam with one end continuous } \delta = 0.0099 \frac{wl^4}{E_cI_x}$$

$$\text{Beam with both ends continuous } \delta = 0.0068 \frac{wl^4}{E_cI_x}$$

The recommended limit to prevent damage to finishes and partitions is the span divided by 250 (Refer to SABS 0100-1 Ed.2.2, clause 4.3.6.2.1).

If the calculated actual long-term deflection is less than the recommended limit, then the beam is okay.

Example:

Beam B1 width 'b' = 1050 mm (From Step 15)

h = t_{beam} = 700 mm (From Step 9)

w = 80.212 kN/m (From Step 26)

Span Length 'L' = 12375 mm (From Figure 25)

$$I_x = \frac{bh^3}{12} = \frac{1050 \text{ mm} \times (700 \text{ mm})^3}{12} = \mathbf{30.013 \times 10^9 \text{ mm}^4}$$

f_{cu} = 30 MPa (From Step 17)

E_c = 28 GPa (From Table 8), therefore E_c = 28 GPa ÷ 2 = **14 GPa**

End span condition = One end continuous

Actual long-term deflection:

$$\delta = 0.0099 \frac{wl^4}{E_cI_x} = \frac{0.0099 \times (80.212 \text{ kN/m}) \times (12375 \text{ mm})^4}{(14 \times 10^3 \text{ GPa}) \times (30.013 \times 10^9 \text{ mm}^4)} = \frac{0.0099 \times (80.212 \times 10^3 \text{ kN/mm}) \times (12375 \text{ mm})^4}{(14 \times 10^{-6} \text{ kN/mm}^2) \times (30.013 \times 10^9 \text{ mm}^4)} = \mathbf{44.322 \text{ mm}}$$

$$\text{Recommended limit} = \frac{\text{Span}}{250} = \frac{12375 \text{ mm}}{250} = \mathbf{49.5 \text{ mm}}$$

44.322 mm < 49.5 mm therefore the long-term deflection of the slab is okay.

If the long-term deflection exceeds the recommended limit, the excessive deflection may be offset by specifying a pre-camber for the beam.

TROUGH SLAB DESIGN

Step 28: Steel detailing of mid-span tension reinforcing steel for the support beams.

The following rules must be taken into consideration when detailing mid-span tension reinforcement:

Rule 1. Span:

- 1.1 The assumption is made that the Span Length 'L' equals the lesser of the clear span plus the effective depth and the distance from centre line to centre line of the supports.

Rule 2. Simply supported beams:

- 2.1 At least 50% of the tension reinforcing steel at mid-span shall extend to the supports and have an effective anchorage of 12 bar diameters beyond the centre line of the support.
- 2.2 No hook or bend shall begin before the centre line.
- 2.3 At least 25% of the reinforcing steel shall extend to within 0.08L of the support centre line and the rest shall extend to within 0.15L of the support centre line.

Rule 3. Cantilever beams:

- 3.1 At least 50% of the tension reinforcing steel shall extend to the end of the cantilever (and be turned down for bond if necessary) and the remaining reinforcing steel shall extend to a distance (from the face of the support) of the greater of 0.5L and 45 bar diameters.

Rule 4. Continuous beams:

- 4.1 At least 30% of the bottom reinforcing steel in tension at mid-span shall extend to the supports.
- 4.2 Half the remainder shall extend to within 0.2L of the centre line of internal supports.
- 4.3 The remaining 35% shall extend to within 0.1L of the centre line of supports.
- 4.4 At a non-continuous end, 50% of the tension reinforcing steel shall extend to the supports and terminate in an effective anchorage as in Rule 2 above and the remainder must extend to within 0.05L of the centre line of the support.

(Refer to SABS 0144 Ed.3, clauses 7.10.4 and 7.10.5).

It is recommended that the above rules are used as a guideline only.

The reinforcing configuration, type, size, and amount or reinforcing steel detailed, will vary between designers and detailers.

It is recommended that reinforcing steel is detailed using the minimum amount of bars and lengths of bars.

Using many different bar lengths and configurations will increase the risk of fixing errors and fixing time on site.

Example (Beam B1 from Figure 25, non-continuous end):

From Rule 4.4, at the non-continuous end, 50% of the tension reinforcement should extend to the supports and terminate in an effective anchorage as in Rule 2 above and the remainder should extend to within 0.05L of the centre line of the support

Number of reinforcing bars = 9 No. Y32 bars at a spacing of 120 mm (From Step 19)

In this case, 5 No. Y32 must extend past the centre line of the supports by at least 12 mm x 32 times the diameter = **384 mm**

The support is not wide enough to accommodate this, thus ensure that there is at least 384 mm anchorage past the centre line of the support and that the bend is located at least the cover distance of 30 mm away from the end of beam (For example, extend the two outermost bars on each face)

The remaining reinforcing bars must extend to within 0.05L of the centre line of the support

Support width = 450 mm (From Figure 25)

d = 638 mm (From Step 17).

From Rule 1, Span Length 'L' = the lesser of (11925 mm + 638 mm) = **12563 mm** and (11925 mm + 225 mm + 225 mm) = **12375 mm**

The remaining reinforcing bars must extend to within (0.05 x 12375 mm) = **619 mm** of the centre line of the supports.

Example (Beam B1 from Figure 25, continuous end):

Rule 4.1:

30% of the 9 No. reinforcing bars = **2.7 bars**

To balance the configuration of the reinforcing bars across the width of the support beam, increase the number of reinforcing bars from 2.7 to 4 bars

These 4 reinforcing bars must extend to the face of the supports.

Rule 4.2:

Half the remainder of the reinforcing bars = (4 bars – 2 bars) = **2 No. bars**

Therefore, 2 No. reinforcing bars, shall extend to within 0.2L of the centre line of internal supports, where:

These reinforcing bars must extend to within (0.2 x 12375 mm) = **2475 mm** from the centre line of the supports.

Rule 4.3:

The remaining 2 No. reinforcing bars shall extend to within 0.1L of the centre line of supports

These reinforcing bars must extend to within (0.1 x 12375 mm) = **1238 mm** from the centre line of the supports.

Note:

Although Rules 4.2 and 4.3 are generally applicable, due to the stirrup configuration, all the reinforcing bars should at least extend all the way up to the inside face of the supports so that the bottom corners of the stirrups can be secured in position.

COFFER AND TROUGH SLAB DESIGN

TROUGH SLAB DESIGN

Figure 27 below shows the bottom tension reinforcement for Beam B1 (Refer to Figure 23).

5 No. reinforcing bars with a bend equivalent to 12 x the bar diameter extended past the centre line of the support

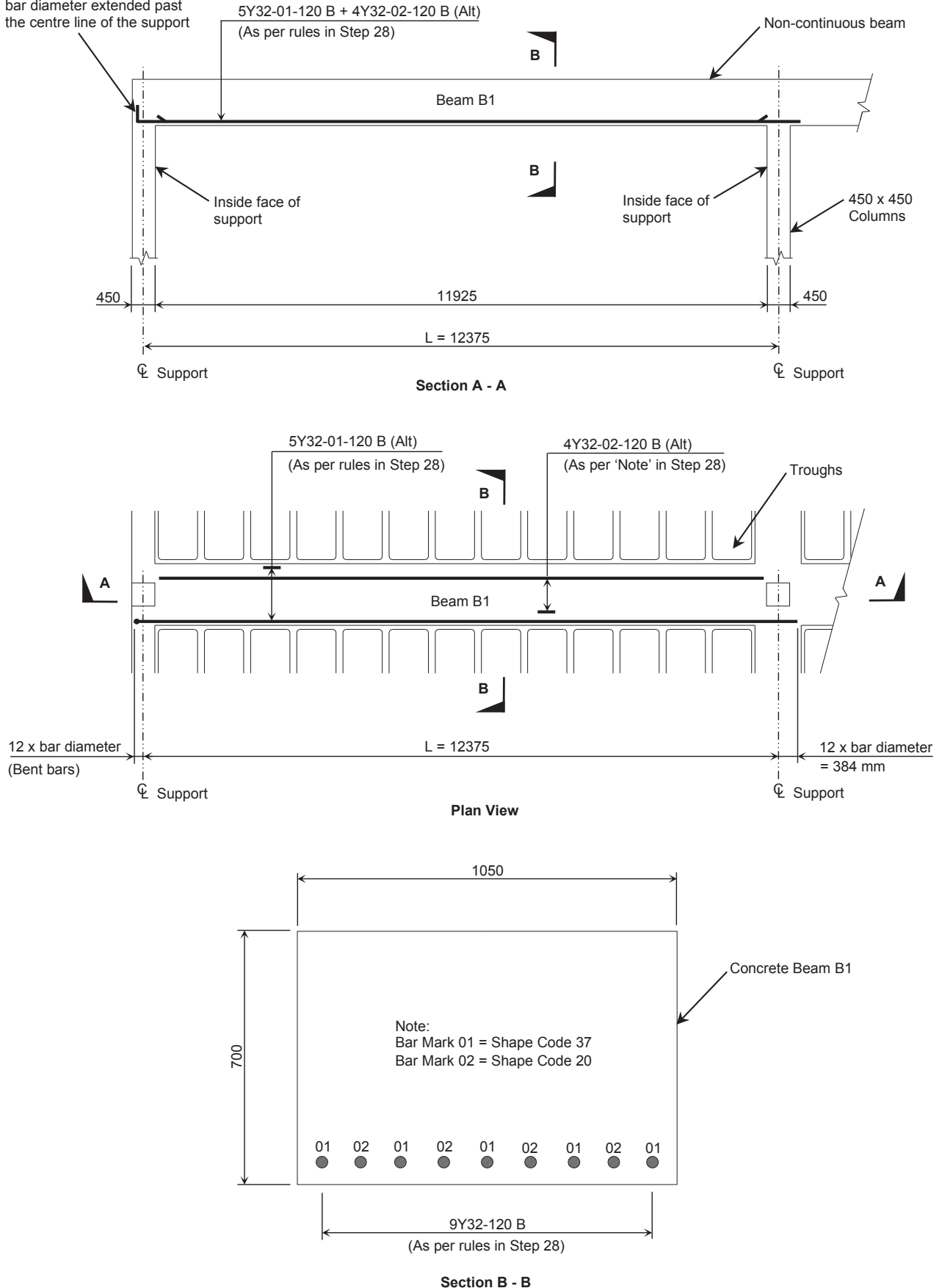

Figure 27 – Bottom Tension Reinforcement For Beam B1

TROUGH SLAB DESIGN

Step 29: Steel detailing of the stirrups for the support beams.

The designer may increase the spacing to achieve a more economical design, provided the spacing is below the maximum spacing of 0.75d.

Provide R16 stirrups type A, B, C and D at a 250 mm spacing (From Step 22), along the full length of Beam B1 (Refer to Figure 25).

In addition to the bottom tension reinforcement, Figure 28 shows the reinforcing stirrups for Beam B1.

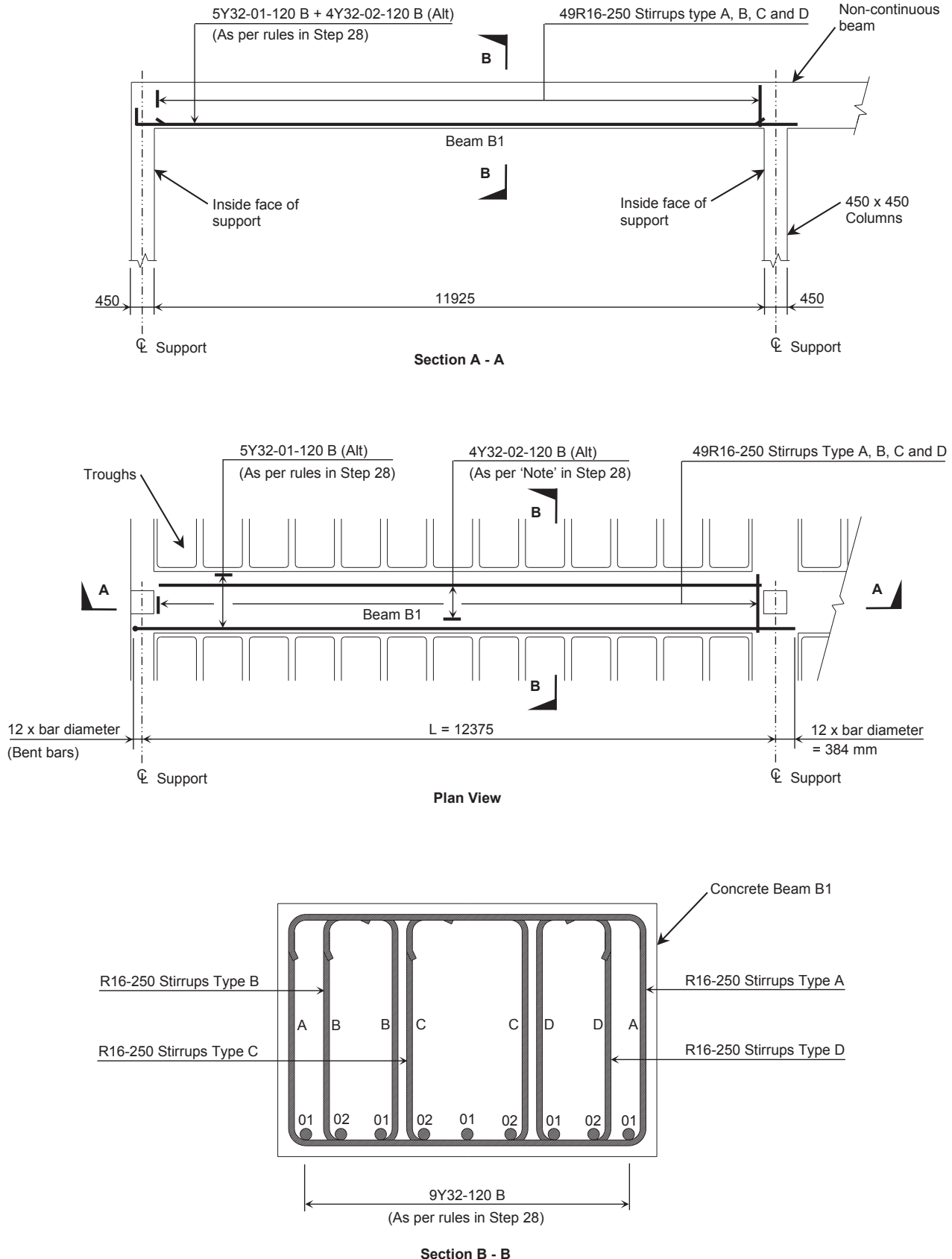

Figure 28 – Bottom Reinforcement And Stirrups For Beam B1

TROUGH SLAB DESIGN

Step 30: Steel detailing of support beam tension reinforcing steel over the supports and nominal top reinforcement at mid-span.

The following rules must be taken into consideration when detailing mid-span tension reinforcement for the support beams of a Trough slab:

Rule 1. Span:

- 1.1 The assumption is made that the Span Length 'L' equals the lesser of the clear span plus the effective depth, and the distance from centre line to centre line of the supports.

Rule 2. Simply supported beams:

- 2.1 No tension reinforcement is required in the top of the beam at the support.

Rule 3. Cantilever beams:

- 3.1 At least 50% of the tension reinforcing steel shall extend to the end of the cantilever (and be turned down for bond if necessary) and the remaining reinforcing steel shall extend to a distance (from the face of the support) of the greater of 0.5L and 45 bar diameters.

Rule 4. Continuous beams:

- 4.1 At least 20% of the top reinforcement in tension over the supports of a continuous beam should be made effectively continuous through the spans. This is also the percentage of reinforcing steel that must extend to the center line of the non-continuous support.
- 4.2 Of the remainder, half should extend to a point at least 0.25L from the face of the support, and the other half to a point at least 0.15L from the face of the support, but no bar should stop at a point less than 45 bar diameters from the face of the support.

(Refer to SABS 0144 Ed.3, clauses 7.10.4 and 7.10.5).

It is recommended that the above rules are used as a guideline only.

The reinforcing configuration, type, size, and amount or reinforcing steel detailed, will vary between designers and detailers.

It is recommended that reinforcing steel is detailed using the minimum amount of bars and lengths of bars.

Using many different bar lengths and configurations will increase the risk of fixing errors and fixing time on site.

Example (Beam B1 from Figure 25, continuous end):

Apply Rule 4 to Beam B1

Beam B1 width 'b' = 1050 mm (From Step 15)

Tension reinforcement = 9 No. Y32 bars at a spacing of 120 mm plus 2 No. Y25 bundled bars (From Step 25)

Beam B1 is continuous one end only (From Figure 25)

Clear span = 11925 mm (From Figure 25)

Supports = 450 mm (Assumed)

d = 638 mm (From Step 17)

L = lesser of (11925 mm + 638 mm) = **12563** mm and (11925 mm + 225 mm + 225 mm) = **12375** mm.

Rule 4.1:

20% of the 9 No. reinforcing bars = **1.8** reinforcing bars

To balance the configuration of the reinforcing bars across the width of the beam, increase the number of reinforcing bars from 1.8 to 2 bars

These 2 No. top reinforcing bars must be continuous through the spans.

Rule 4.2:

The remainder of the reinforcing bars = (9 bars – 2 bars) = **7** No. bars

These 7 No. Y32 bars plus 2 No. Y25 bundled bars make up the 80% balance of the top reinforcing bars

Allow the remaining 7 No. reinforcing bars to extend past the face of the support by the larger of 0.25L or 45d from the face of the support

(0.25 x 12375 mm) = **3094** mm and (45 x 32 mm) = **1440** mm

Therefore, extend the remaining 7 No. top reinforcing bars 3094 mm (**3100** mm rounded up) past the face of the support.

Note:

To assist with the fixing of the reinforcing bars, it may be prudent to have the same number of top and bottom reinforcing bars

The 7 No. remaining top reinforcing bars may be made continuous, through the length of the beam, using a reduced reinforcing bar diameter

The designer can use any reduced reinforcing bar diameter because the minimum required area of steel is already in place

In this case, it would be the most economical to use 2 No. Y32 and 7 No. Y12 top reinforcing bars over the length of the beam.

Example (Beam B1 from Figure 25, non-continuous end):

Apply Rule 4.1 to Beam B1

20% of the 9 No. reinforcing bars = **1.8** reinforcing bars

To balance the configuration of the reinforcing bars across the width of the beam, increase the number of reinforcing bars from 1.8 to 2 bars

These 2 No. top reinforcing bars must terminate at the center line of the non-continuous support.

TROUGH SLAB DESIGN

In addition to the bottom tension reinforcement and stirrups, Figure 29 shows the top reinforcing bars for Beam B1 (Refer to Figure 25).

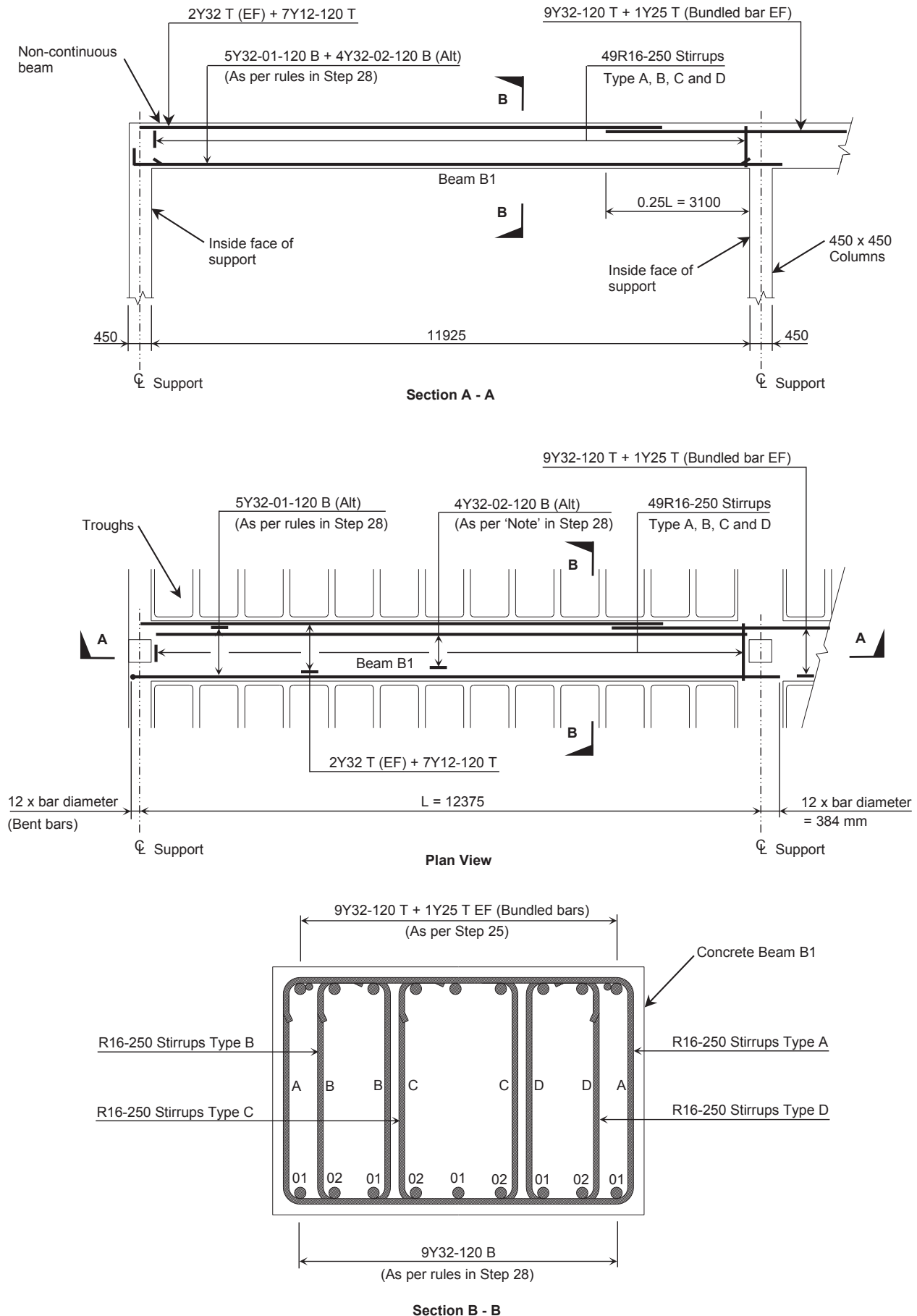

Figure 29 – Top And Bottom Reinforcement And Stirrups For Beam B1

TROUGH SLAB DESIGN

PART 3 – Trough slab design – ribs and structural topping (Steps 31 to 50)

Step 31: Identify and name the Trough portions between the beams.

All the beams should be designed as per Steps 1 to 30, before starting the design of the Trough portions of the slab.

Identify all the Trough portions between the support beams, for example A1/B1, A2/B2, etc. as shown in Figure 30.

The identification of each Trough portion will be used as a cross reference during the design phase and later when scheduling the reinforcing steel.

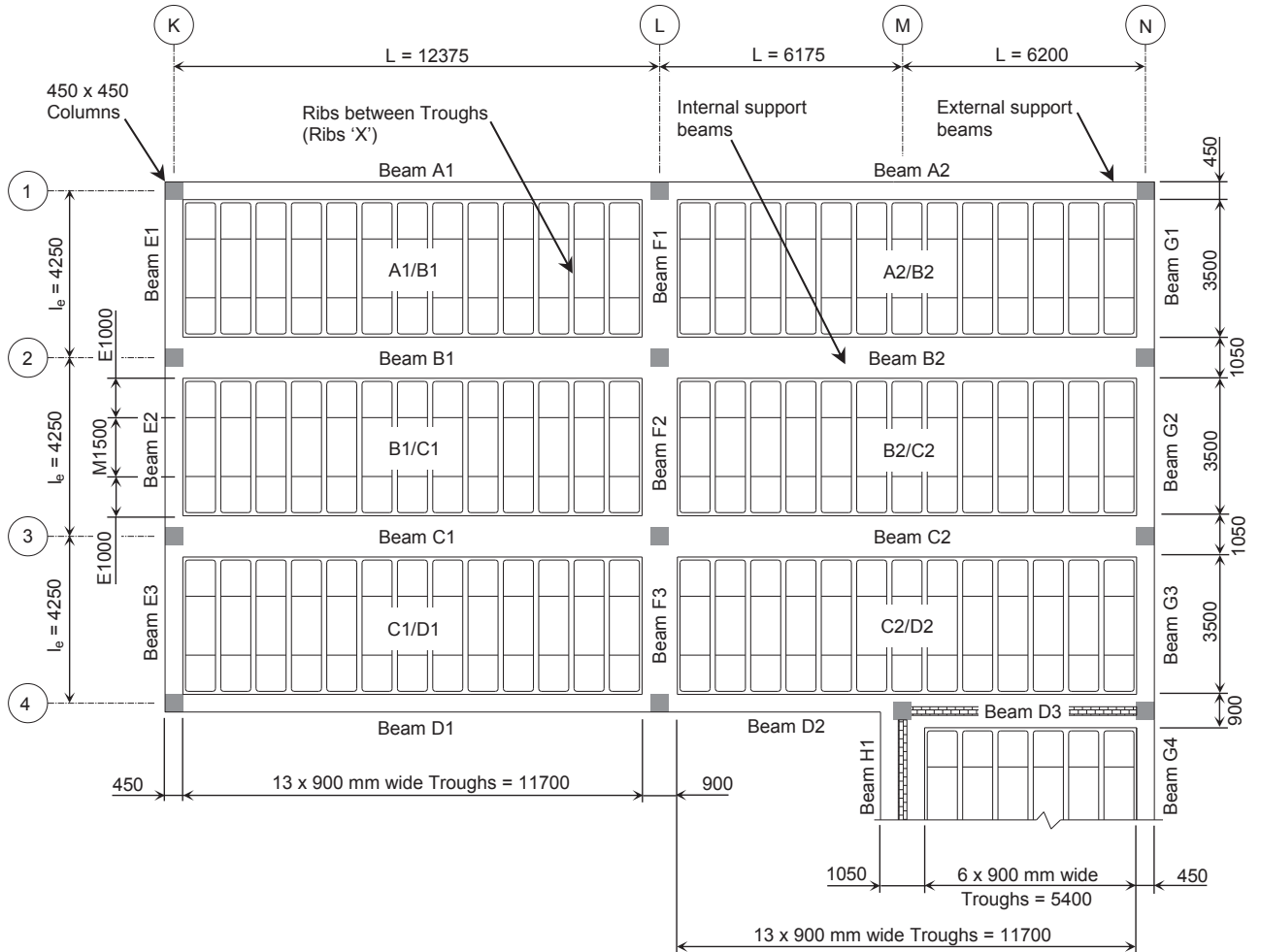

Figure 30 – Typical Beam And Trough Layout Showing Various Trough Portions In-between Beams

Step 32: Select a Trough portion and identify the specific details from the drawing.

Select a Trough portion, for example portion A1/B1 in Figure 30 and determine the Trough length, width of the support beams, effective length and supporting conditions.

Example:

Trough length = span length of ribs between supports beams = 3500 mm

Support Beam A1 = 450 mm wide (Discontinuous ribs)

Support Beam B1 = 1050 mm wide (Continuous ribs)

The effective length $l_e = 3500 \text{ mm} + ((450 \text{ mm} + 1050 \text{ mm}) \div 2) = 4250 \text{ mm}$

End span condition = continuous one end over Beam B1.

TROUGH SLAB DESIGN

Step 33: Determine the minimum structural topping thickness due to deflection, for the selected Trough height.
The total slab thickness will remain the same as previously determined in Step 9.

Example:

Trough height + topping = 625 mm Trough + 75 mm Topping (From Step 9)

Refer to Figure 24 and Table 19 for the minimum structural topping thickness for the different Trough sizes.

Step 34: Determine the self-weight of the Trough slab and imposed loads on the Trough slab.
The self-weight and imposed loads acting on the Trough slab will be the same as determined in Steps 9 & 12.

Example:

Trough slab self-weight = 9.300 kN/m² (From Step 9)

Trough slab imposed load = 5.0 kN/m² (From Step 12)

$w_{slab} = (1.2 \times 9.300 \text{ kN/m}^2) + (1.6 \times 5.0 \text{ kN/m}^2) = 19.160 \text{ kN/m}^2$

Step 35: Determine the span end conditions and maximum moments of the Trough slab.
Every slab will have ribs as shown in Figure 30.

Table 20 may be used to determine the maximum moments and maximum shear loads, but it is advised that the designer verifies the results using specialist beam analysis software.

Table 20 - Ultimate Bending Moments And Shear Forces In One-way Spanning Slabs		
Position	Moment	Shear
At outer support	0	0.4F
Near middle of end span	0.086Fl	0
At first internal support	0.086Fl	0.6F
At middle of internal spans	0.063Fl	0
At internal supports	0.063Fl	0.5F

Extract from SABS 0100-1 Ed.2.2, Table 13

Where F = The total ultimate load (1.2G_n + 1.6 Q_n)

Example:

$l_e = 4250 \text{ mm}$ (From Step 32)

$w_{slab} = 19.160 \text{ kN/m}^2$ (From Step 34)

$w_{rib} = 19.160 \text{ kN/m}^2 \times 0.9 \text{ m per rib} = 17.244 \text{ kN/m per rib}$

$F = wl$

$M_{sup,outer} = 0 \text{ kN.m}$

$M_{sup,inner} = -0.086Fl = -0.086 \times 17.244 \text{ kN} \times (4.250 \text{ m})^2 = -26.786 \text{ kN.m per rib}$

$M_{mid-span} = 0.086Fl = 0.086 \times 17.244 \text{ kN} \times (4.250 \text{ m})^2 = 26.786 \text{ kN.m per rib.}$

TROUGH SLAB DESIGN

Step 36: Determine the moment of resistance for each Trough rib.

The effective depth of the reinforcing steel is required to determine the moment of resistance.

The effective depth 'd' is the depth from external face of the compression zone of the beam to the centre of the tension reinforcement as stated in SABS 0100-1 Ed.2.2, clause 4.3.3.3.

Assume the concrete cover to reinforcing steel = 30 mm (From Step 7).

The relevant cover to reinforcing steel must be chosen depending on the requirement of structure.

Assume the width of the rib to be the width at the bottom of the rib and not the width at the top of the rib where the rib and the structural topping meets.

The width $b_{rib.bot}$ of the rib used in the moment of resistance calculation will then always be taken as 180 mm (Refer to Figure 24).

Assume the redistribution of moments do not exceed 10%, therefore $K = 0.156$ (Refer SABS 0100-1 Ed.2.2, clause 4.3.3.4.1).

Assume concrete strength = 30 MPa.

If the moment of resistance is substantially bigger than the actual maximum bending moments over the complete design, an option would be to increase the concrete strength.

The moment of resistance is determined using the following equation:

$$M_r = Kbd^2f_{cu} \text{ (Refer to SABS 0100-1 Ed.2.2, clause 4.3.3.4.1)}$$

Example:

$$b_{rib.bot} = 180 \text{ mm (From above)}$$

$$f_{cu} = 30 \text{ MPa (From Step 17)}$$

$$K = 0.156 \text{ (Moment distribution smaller than 10\%)}$$

$$t_{beam} = 700 \text{ mm (From Step 9)}$$

$$\text{Cover} = 30 \text{ mm (From above)}$$

$$\text{Tension reinforcing steel} = Y20 \text{ (Assumed)}$$

$$\text{Stirrup} = R8 \text{ (Assumed)}$$

$$d = t_{beam} - \text{cover} - \text{half bar diameter} - \text{diameter}_{stirrup} = 700 \text{ mm} - 30 \text{ mm} - (20 \text{ mm} \div 2) - 8 \text{ mm} = \mathbf{652 \text{ mm}}$$

$$M_r = Kbd^2f_{cu} = 0.156 \times 180 \text{ mm} \times (652 \text{ mm})^2 \times 30 \text{ MPa} \div 1\,000\,000 = 0.156 \times 0.180 \text{ m} \times (0.652 \text{ m})^2 \times 0.03 \times 10^6 \text{ kN/m}^2 = \mathbf{358.108 \text{ kN.m.}}$$

TROUGH SLAB DESIGN

Step 37: Determine the area of tension reinforcing steel required for each rib at mid-span.

Check if only tension reinforcement is required, or if tension and compression reinforcement is required, for the rib.

This is achieved by checking the 'K' value with the applied bending moment, where:

$$K = \frac{M_{u,\text{mid}}}{bd^2f_{cu}} \quad (\text{Refer to SABS 0100-1 Ed.2.2, clause 4.3.3.4.1})$$

If $K > 0.156$, then compression reinforcing steel is required in addition to the tension reinforcing steel.

This Concrete Design Guide does not deal with the design for compression reinforcing steel.

Example:

This example will only consider the largest mid-span moment

$$M_{s,\text{mid-span}} = 26.786 \text{ kN.m} \quad (\text{From Step 35})$$

$$b_{\text{rib,bot}} = 180 \text{ mm} \quad (\text{From Step 36})$$

$$d = 652 \text{ mm} \quad (\text{From Step 36})$$

$$f_{cu} = 30 \text{ MPa} \quad (\text{From Step 17})$$

$$K = \frac{26.786 \text{ kN.m} \times 1000000}{180 \text{ mm} \times (652 \text{ mm})^2 \times 30 \text{ MPa}} = \frac{26.786 \text{ kN.m}}{0.180 \text{ m} \times (0.652 \text{ m})^2 \times 30 \text{ kN/m}^2} = 0.012$$

$K < 0.156$, therefore only tension reinforcement is required

Determine the lever arm 'z'

The value of 'z' is the lesser of $0.95d$ and $d \times (0.5 + \sqrt{(0.25 - (K \div 0.9))})$ (Refer to SABS 0100-1 Ed.2.2, clause 4.3.3.4.1)

The required area of tension reinforcement at mid-span is determined using the following equation:

$$A_{s,\text{req}} = \frac{M_{u,\text{mid}}}{0.87f_y z}$$

The area of tension reinforcing steel should not exceed 4% of the gross cross-sectional area of the beam.

The minimum percentage of reinforcing steel for a flanged beam with the web in tension is given in Table 12.

Determine the required area of tension reinforcement:

$$M_{s,\text{mid-span}} = 26.786 \text{ kN.m} \quad (\text{From Step 35})$$

$$f_y = 450 \text{ MPa} \quad (\text{From Step 18})$$

$$d = 652 \text{ mm} \quad (\text{From Step 36})$$

$$z = \text{lesser of } 0.95 \times 652 \text{ mm} = \mathbf{360} \text{ mm} \text{ and } 652 \times (0.5 + \sqrt{(0.25 - (0.012 \div 0.9))}) = \mathbf{619} \text{ mm}$$

$$t_{\text{beam}} = 700 \text{ mm} \quad (\text{From Step 9})$$

$$b_{\text{rib,ave}} = (b_{\text{rib,top}} + b_{\text{rib,bot}}) \div 2 = (336 \text{ mm} + 180 \text{ mm}) \div 2 = \mathbf{258} \text{ mm} \quad (\text{From Table 19})$$

$$A_{s,\text{req}} = \frac{M_{s,\text{mid-span}}}{0.87f_y z} = \frac{26.786 \text{ kN.m}}{0.87 \times 450 \text{ MPa} \times 619 \text{ mm}} = \frac{26.786 \times 10^3 \text{ kN.mm}}{0.87 \times 450 \times 10^{-3} \text{ kN/mm}^2 \times 619 \text{ mm}} = \mathbf{111} \text{ mm}^2 \text{ per rib}$$

$$A_c = b_{\text{rib,ave}} \times t_{\text{beam}} = 258 \text{ mm} \times 700 \text{ mm} = \mathbf{180.6 \times 10^3} \text{ mm}^2 \text{ per rib}$$

$$A_{s,\text{min}} = 0.13 \times A_c \div 100 = 0.13 \times 180.6 \times 10^3 \div 100 = \mathbf{235} \text{ mm}^2 \text{ per rib}$$

$$A_{s,\text{max}} = 4\% \times A_c = 0.04 \times (180.6 \times 10^3 \text{ mm}^2) = \mathbf{7224} \text{ mm}^2 \text{ per rib}$$

$$A_{s,\text{req}} < A_{s,\text{min}} \text{ therefore } A_{s,\text{req}} = \mathbf{235} \text{ mm}^2.$$

TROUGH SLAB DESIGN

Step 38: Select the spacing and type of reinforcing steel to be used for the ribs to cater for mid-span bending.

The required area of reinforcing steel for the ribs has been established.

The diameter and spacing of the reinforcing bars must now be determined.

The ribs are spaced at 900 mm (As shown in Figure 30), and assuming that only 1 No. reinforcing bar is used per rib, a reinforcing bar spacing of 900 mm is accepted.

The total width of a rib at the bottom is 180 mm (From Table 19).

If it is not possible to have only one reinforcing bar (due to the imposed moments), the designer can use more reinforcing bars, but the spacing within the rib must be checked to ensure that there is adequate space for concrete to flow around the reinforcing bars.

The required cross-sectional area ($A_{s,req}$) per reinforcing bar can be determined by dividing the total area of reinforcing steel required per metre by the number of reinforcing bars provided at a spacing of 900 mm.

Table 7 must be used to determine the diameter of the reinforcing bars that are required to meet the minimum cross-sectional area requirements.

The designer must now check that the assumed calculated spacing is smaller than the maximum spacing allowed for the specific section if more than one reinforcing bar is required.

The maximum spacing of reinforcing bars is the smaller of 300 mm or $47000 \div f_s$ (Refer to SABS 0100-1 Ed.2.2, clause 4.11.8.2.1.4). (Note that this only applies to slabs and beams).

By default, the ribs are spaced at 900 mm center to center which is allowed for in the reinforcement calculation.

$$\text{The service stress } f_s = 0.87f_y \times \frac{y_1 + y_2}{y_3 + y_4} \times \frac{A_{s,req}}{A_{s,prov}} \times \frac{1}{\beta_b} \quad (\text{Refer to SABS 0100-1 Ed.2.2, clause 4.3.6.3.1})$$

Where:

y_1 = self-weight load factor for serviceability limit states = 1.1

y_2 = imposed load factor for serviceability limit states = 1.0

y_3 = self-weight load factor for ultimate limit states = 1.2

y_4 = imposed load factor for ultimate limit states = 1.6

β_b = ratio of resistance moment at mid-span obtained from the redistributed maximum moments diagram to that obtained from the maximum moments diagram before redistribution = 1.0
(Refer to SABS 0100-1 Ed.2.2, clause 4.3.6.3.1; SANS 10160-1, Table 3, and SANS 10160-1, clause 8.3.1.1).

Example:

Number of reinforcing bars = 1 No. per rib (Reinforcing bar spacing is not applicable because only 1 No. reinforcing bar is used)

$b_{rib,bot}$ = 180 mm (From Table 19)

f_y = 450 MPa = 450 N/mm² (From Step 18)

$A_{s,req}$ = 235 mm² per rib (From Step 37)

Area of 1 No. Y20 reinforcing bar = 314 mm² (From Table 7)

$A_{s,prov}$ = 314 mm² which is greater than the required area of 235 mm², therefore 1 No. Y20 reinforcing bar is sufficient to cater for the moment

$$\text{The service stress } f_s = 0.87(450 \text{ N/mm}^2) \times \frac{1.1 + 1.0}{1.2 + 1.6} \times \frac{235 \text{ mm}^2}{314 \text{ mm}^2} \times \frac{1}{1.0} = \mathbf{220 \text{ N/mm}^2}$$

$$47000 \div f_s = 47000 \div 220 \text{ N/mm}^2 = \mathbf{214 \text{ mm}}$$

By default, the spacing of 214 mm will not be applicable in the rib calculation due to the ribs being at a spacing of 900 mm centre to centre.

TROUGH SLAB DESIGN

Step 39: Selecting the number of stirrups for the ribs.

It is good practice to have longitudinal bars in the corners of each stirrup.

The number of stirrups is based on the number of longitudinal tension reinforcing bars present in the rib under consideration.

Each stirrup in the ribs has 2 vertical legs (As shown in Figure 31) which provides a central position at the bottom for 1 No. longitudinal tension reinforcing bar.

The intervals or spacing at which the stirrups are positioned along the length of the rib, is based on the shear resistance required for the rib as discussed in Step 40.

Assume all stirrups are R8 mild steel reinforcing bars.

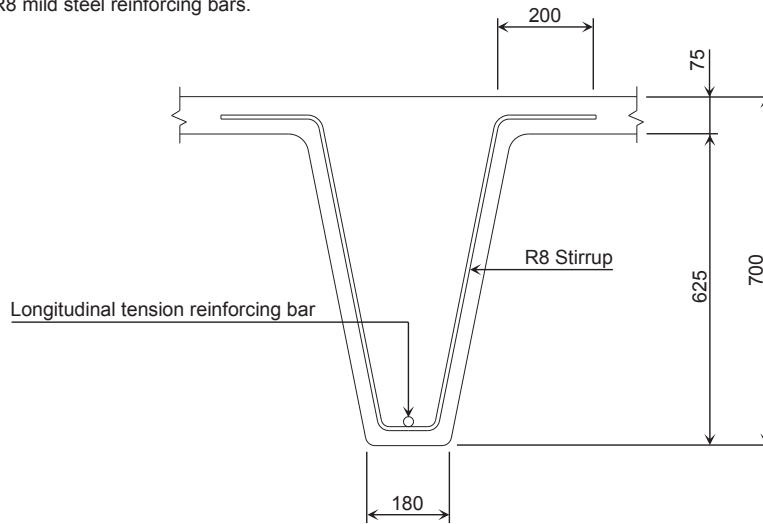

Figure 31 – Typical Cross-Section Showing Stirrup In Trough Rib

Step 40: Check the shear resistance of the rib.

The design shear force due to the design maximum loads for the ultimate limit state must be determined.

Example:

$w_{rib} = 17.244$ kN/m per rib (From Step 35)

$l_e = 4250$ mm (From Step 32)

$V_{sup,outer} = 0.4F$ (From Table 20) = 0.4×17.244 kN $\times 4.250$ m = **29.315** kN

$V_{sup,inner} = 0.6F$ (From Table 20) = 0.6×17.244 kN $\times 4.250$ m = **43.972** kN

The design shear stress 'v' at any x-section of the rib shall not exceed a value of the lesser of $0.75\sqrt{f_{cu}}$ or 4.75 MPa (Refer to SABS 0100-1 Ed.2.2, clause 4.3.4.1.1)

Design shear stress $v = \frac{V}{bd}$ (Refer to SABS 0100-1 Ed.2.2, clause 4.3.4.1.1)

Maximum design shear stress of concrete $v_c = \frac{0.75}{\gamma_m} \left(\frac{f_{cu}}{25} \right)^{1/3} \left(\frac{100A_s}{b_v d} \right)^{1/3} \left(\frac{400}{d} \right)^{1/4}$ (Refer to SABS 0100-1 Ed.2.2, clause 4.3.4.1.2)

$\frac{100A_s}{b_v d}$ shall not be taken as greater than 3. (Refer to SABS 0100-1 Ed.2.2, clause 4.3.4.1.2)

The design shear stress should be less than the maximum design shear stress, if not, additional shear reinforcing steel must be added.

The cross-section of a rib cannot be altered to allow for increased shear capacity as was the case in the design of the support beams.

To determine the required ratio of shear reinforcement to reinforcing bar spacing, apply the following equation:

$$\frac{A_{sv}}{s_v} \geq \frac{b(v - v_c)}{0.87f_{yv}}$$

Where:

A_{sv} is the cross-sectional area of the two legs of a stirrup

f_{yv} is the characteristic strength of the stirrup reinforcement (R8 = 250 MPa) (Refer to SABS 0100-1 Ed.2.2, clause 4.3.4.1.3).

TROUGH SLAB DESIGN

Example:

Partial safety factor for materials for shear strength without shear reinforcement and shear taken by concrete in combination with shear reinforcement $\gamma_m = 1.40$ (Refer to SABS 0100-1 Ed.2.2, clause 3.3.3.2)

$$V_{\text{sup,inner}} = 0.6F = 0.6 \times 117.244 \text{ kN} \times 4.250 \text{ m} = \mathbf{43.972 \text{ kN}}$$

Therefore, design shear force $V = 43.972 \text{ kN}$ per rib

(The designer should prepare a proper beam analysis to determine the reaction forces on each support using specialist software packages)

$d = 652 \text{ mm}$ (From Step 36)

$b_{\text{rib,ave}} = 258 \text{ mm}$ (From Step 37)

$$\text{Design shear stress } v = \frac{V}{bd}$$

$$v = \frac{43.972 \text{ kN}}{258 \text{ mm} \times 652 \text{ mm}} = \frac{43.972 \times 10^3 \text{ N}}{258 \text{ mm} \times 652 \text{ mm}} = 0.261 \times 10^3 \text{ N/mm}^2 = \mathbf{0.261 \text{ MPa}}$$

$f_{cu} = 30 \text{ MPa}$ (From Step 17)

Maximum shear stress $v_{\text{max}} = \text{smaller of } 0.75\sqrt{30} = \mathbf{4.108 \text{ MPa}}$ and $\mathbf{4.75 \text{ MPa}}$

$v < v_{\text{max}}$ therefore okay

$A_{s,\text{prov}} = 1 \text{ No. Y16 reinforcing bar} = \mathbf{314 \text{ mm}^2}$ (From Step 38)

$$\frac{100A_s}{b_v d} = \frac{100 \times 314 \text{ mm}^2}{258 \text{ mm} \times 652 \text{ mm}} = \mathbf{0.187} < 3, \text{ therefore okay}$$

$$v_c = \frac{0.75}{1.4} \left(\frac{30 \text{ MPa}}{25} \right)^{1/3} (0.187)^{1/3} \left(\frac{400}{652 \text{ mm}} \right)^{1/4} = \mathbf{0.288 \text{ MPa}}$$

$v < v_c$ therefore no additional shear reinforcement is required

Determine the required ratio of shear reinforcement to reinforcing bar spacing:

$$\frac{A_{sv}}{s_v} \geq \frac{b(v - v_c)}{0.87f_{yv}}$$

$$\frac{A_{sv}}{s_v} \geq \frac{258 \text{ mm} (0.261 \text{ MPa} - 0.288 \text{ MPa})}{0.87 \times 250 \text{ MPa}} = \mathbf{-0.032} \text{ (This ratio will be used in Step 41 to determine the spacing of the stirrups)}$$

The negative value is a further indication that no shear reinforcement is required and that the longitudinal tension reinforcement is sufficient to cater for the shear.

TROUGH SLAB DESIGN

Step 41: Determine the spacing of the stirrups in the ribs.

s_v is the spacing of the stirrups along a rib.

The spacing should not exceed 0.75 times the effective depth of the reinforcement.

The initial assumption is made that the spacing of the stirrups is just below 0.75 times the effective depth of the reinforcing steel.

If the assumed spacing of the stirrups is found to be insufficient, the spacing must be reduced accordingly.

If the following equation is true, then the spacing is okay, if not, reduce the spacing:

$$\frac{A_{sv}}{s_v} \geq \frac{b(v - v_c)}{0.87f_{yv}}$$

Where:

A_{sv} is the cross-sectional area of the two legs of a stirrup

f_{yv} is the characteristic strength of the stirrup reinforcement (R8 = 250 MPa)
(Refer to SABS 0100-1 Ed.2.2, clause 4.3.4.1.3)

Example:

$d = 652$ mm (From Step 36)

$s_{v,max} = 0.75d = (0.75 \times 652 \text{ mm}) = 489$ mm

Assumed stirrup spacing $s_v = 450$ mm

$s_v < s_{v,max}$ therefore okay

Number of R8 stirrups = 1 No. (From Figure 31)

Thus number of legs = 1 No. stirrup \times 2 legs per stirrup = 2 No. legs

R8 cross-sectional area = 50 mm² (Refer to Table 7)

$A_{sv,prov} = 2 \text{ No.} \times 50 \text{ mm}^2 = 100$ mm²

$$\frac{A_{sv}}{s_v} = -0.032 \text{ (From Step 40)}$$

$A_{sv,req} = -0.032 \times 450 \text{ mm} = -14.41$ mm². The area required cannot be less than 0, therefore accept R8 stirrups at a spacing of 450 mm

$A_{sv,prov} > A_{sv,req}$ therefore okay.

Step 42: Determine the area of nominal reinforcement at mid-span and at the supports for the Trough slab.

A single layer of mesh reinforcement should be provided to control cracking in the structural topping.

The mesh should have a cross-sectional area of at least 0.12% of the cross-sectional area of the topping, in each direction, and the spacing of the bars in the mesh should not exceed half the centre to centre distance between the ribs.

(Refer to SABS 10100-1 Ed.2.2, clause 4.5.6.2.2).

Example:

$t_{topping} = 75$ mm (From Step 9)

$b_{topping} = 900$ mm per rib

$A_c = t_{topping} \times b_{topping} = 75 \text{ mm} \times 900 \text{ mm} = 67.5 \times 10^3$ mm²

$A_{s,mesh} = 0.12 \% \times 67.5 \times 10^3 \text{ mm}^2 = 81$ mm² per 900 mm wide structural topping over each rib

Referring to Table 13, Mesh Ref 193 = 98.4 mm² > 81 mm²

Use Mesh Ref 193 for the nominal reinforcement.

TROUGH SLAB DESIGN

Step 43: Determine the area of tensile reinforcing steel required for the rib at the support beam.

Check if only tension reinforcement is required, or if tension and compression reinforcement is required, for the rib.

This is achieved by checking the 'K' value with the applied bending moment, where:

$$K = \frac{M_{u,\text{sup}}}{bd^2f_{cu}} \quad (\text{Refer to SABS 0100-1 Ed.2.2, clause 4.3.3.4.1})$$

If $K > 0.156$, then compression reinforcing steel is required in addition to the tension reinforcing steel.

This Concrete Design Guide does not deal with the design for compression reinforcing steel.

Example:

$b_{\text{rib,ave}} = 258 \text{ mm}$ (From Table 19)

$M_{\text{sx,support}} = -26.786 \text{ kN.m}$ (From Step 35)

$d = 652 \text{ mm}$ (From Step 36)

$f_{cu} = 30 \text{ MPa}$ (From Step 17)

$$K = \frac{26.786 \text{ kN.m}}{258 \text{ mm} \times (652 \text{ mm})^2 \times 30 \text{ MPa}} = \frac{26.786 \text{ kN.m}}{0.258 \text{ m} \times (0.652 \text{ m})^2 \times 30 \times 10^3 \text{ kN/m}^2} = \mathbf{0.008}$$

Thus $K < 0.156$, therefore only tension reinforcement is required

Determine the lever arm 'z'

The value of 'z' is the lesser of $0.95d$ and $d \times (0.5 + \sqrt{(0.25 - (K \div 0.9))})$ (Refer to SABS 0100-1 Ed.2.2, clause 4.3.3.4.1)

The required area of tension reinforcement is determined using the following equation:

$$A_{s,\text{req}} = \frac{M_{u,\text{sup}}}{0.87f_y z}$$

The area of tension reinforcing steel should not exceed 4% of the gross cross-sectional area of the beam.

The minimum percentage of reinforcing steel for a flanged beam is given in Table 14.

$M_{\text{sx,support}} = -26.786 \text{ kN.m}$ per rib (From Step 35)

$f_y = 450 \text{ MPa}$ (From Step 18)

$d = 652 \text{ mm}$ (From Step 36)

$z = \text{lesser of } 0.95 \times 652 \text{ mm} = \mathbf{619 \text{ mm}}$ and $652 \times (0.5 + \sqrt{(0.25 - (0.008 \div 0.9))}) = \mathbf{646 \text{ mm}}$

$$A_{s,\text{req}} = \frac{26.786 \text{ kN.m}}{0.87 \times 450 \text{ MPa} \times 619 \text{ mm}} = \frac{26.786 \times 10^3 \text{ kN.mm}}{0.87 \times 450 \times 10^{-3} \text{ kN/mm}^2 \times 619 \text{ mm}} = \mathbf{111 \text{ mm}^2}$$

$t_{\text{topping}} = 75 \text{ mm}$ (From Step 9)

$b_{\text{topping}} = 900 \text{ mm}$ per rib (From Step 42)

$A_c = t_{\text{topping}} \times b_{\text{topping}} = 75 \text{ mm} \times 900 \text{ mm} = \mathbf{67.5 \times 10^3 \text{ mm}^2}$

$A_{s,\text{min}} = 0.26 \times A_c \div 100 = 0.26 \times 67.5 \times 10^3 \div 100 = \mathbf{176 \text{ mm}^2}$

$A_{s,\text{max}} = 4\% \times A_c = (0.04 \times 67.5 \times 10^3 \text{ mm}^2) = \mathbf{2700 \text{ mm}^2}$

$A_{s,\text{max}} > A_{s,\text{req}} > A_{s,\text{min}}$ therefore $A_{s,\text{req}} = \mathbf{176 \text{ mm}^2}$ per rib (Or every 900 mm center to center of ribs).

TROUGH SLAB DESIGN

Step 44: Select the spacing and type of tensile reinforcing steel to be used at the rib support for bending.

The required area of tensile reinforcement required for the rib at the support beam has been established.

The diameter and spacing of the reinforcing bars must now be determined.

The designer can assume the spacing between top tensile reinforcing bars to be 900 mm centre to centre, because this is the spacing of the ribs.

Compare the cross-sectional area determined in Step 43 to the values given in Table 7, to determine the minimum diameter of the reinforcing bars required.

Note:

If there is a marginal shortfall of top reinforcement, the mesh reinforcing in the structural topping should be taken into account, as calculated in Step 42.

Example:

$$b_{\text{topping}} = 900 \text{ mm per rib (From Step 42)}$$

$$f_y = 450 \text{ MPa} = 450 \text{ N/mm}^2 \text{ (From Step 18)}$$

$$A_{s,\text{req}} = 176 \text{ mm}^2 \text{ per 900 mm rib spacing (From Step 43) due to the minimum cross-sectional area of the concrete structural topping}$$

$$A_{s,\text{req}} = 111 \text{ mm}^2 \text{ per 900 mm rib spacing (From Step 43) due to the actual support moment}$$

$$A_{s,\text{mesh}} = 98.4 \text{ mm}^2 \text{ per 900 mm wide structural topping over each rib (From Step 42)}$$

$$\text{Therefore, the new area of steel required } A_{s,\text{req,new}} = 176 \text{ mm}^2 - 98.4 \text{ mm}^2 = \mathbf{77.6 \text{ mm}^2}$$

From Table 7, 1 No. Y12 reinforcing bar with a cross-sectional area of 113 mm² in the structural topping is sufficient

$$\text{The total area } A_{s,\text{prov}} = 98.4 \text{ mm}^2 + 113 \text{ mm}^2 = \mathbf{211.4 \text{ mm}^2}$$

$$A_{s,\text{prov}} > A_{s,\text{req}} \text{ therefore tension reinforcing steel okay}$$

$$\text{The service stress } f_s = 0.87(450 \text{ N/mm}^2) \times \frac{1.1 + 1.0}{1.2 + 1.6} \times \frac{176 \text{ mm}^2}{211.4 \text{ mm}^2} \times \frac{1}{1.0} = \mathbf{244 \text{ N/mm}^2}$$

$$47000 \div f_s = 47000 \div 244 \text{ N/mm}^2 = \mathbf{193 \text{ mm}}$$

The mesh reinforcing bar spacing of 200 mm for is larger than the maximum spacing of 193 mm.

In this case, the 1 No. Y12 provided (113 mm²) is larger than the actual area of steel required due to the moment (111 mm²), therefore the spacing can be ignored.

TROUGH SLAB DESIGN

Step 45: Check the deflections based on the basic allowable span of the ribs.

To prevent damage to finishes and partitions for beams of spans up to 10 m, the deflection must be limited to span divided by 250.

The basic span/effective depth ratios are given in Table 4.

Serviceability Limit State Load = 1.1DL + 1.0LL (Refer to SANS 10160-1, clause 8.3.1.1).

The basic span/effective depth ratio value obtained from Table 4 must be modified with a modification factor that takes into account the amount of tension reinforcement and the associated stresses when the allowable span/effective depth ratio is calculated.

The modification factor is derived from the following equation:

$$\text{Modification factor} = 0.55 + \frac{477 - f_s}{120 \left(0.9 + \frac{M_u}{bd^2} \right)} \leq 2.0 \quad (\text{Refer to SABS 0100-1 Ed.2.2, clause 4.3.6.3.1})$$

The allowable span/effective depth ratio will then be the basic span/effective depth ratio multiplied by the calculated modification factor.

The actual span/effective depth ratio can now be calculated from the rib layout shown in Figure 30.

If the actual span/effective depth ratio is bigger than the allowable span/effective depth ratio, the rib fails due to deflection.

Example:

End span condition = Continuous one end over Beam B1 (Trough slab A1/B1 from Figure 30)

DL_{slab} = 9.300 kN/m² (From Step 9)

DL_{rib} = 9.300 kN/m² x 0.9 m per rib = **8.370 kN/m** per rib

LL_{slab} = 5.0 kN/m² (From Step 12).

LL_{rib} = 5.0 kN/m² x 0.9 m per rib = **4.5 kN/m** per rib

Rib Ultimate Load w_{rib,ult} = (1.2 x 8.370 kN/m) + (1.6 x 4.5 kN/m) = **17.244 kN/m** per rib

Rib Serviceability load w_{rib,ser} = (1.1 x 8.37 kN/m) + (1.0 x 4.5 kN/m) = **13.707 kN/m** per rib

Determine the service stress:

A_{s,req} = 235 mm² per rib (From Step 37)

A_{s,prov} = 314 mm² (From Step 38)

f_y = 450 MPa = 450 N/mm² (From Step 18)

The service stress f_s = 0.87(450 MPa) x $\frac{y_1 + y_2}{y_3 + y_4}$ x $\frac{A_{s,req}}{A_{s,prov}}$ x $\frac{1}{\beta_b}$ (Refer to SABS 0100-1 Ed.2.2, clause 4.3.6.3.1)

$$\text{Service stress } f_s = 0.87(450 \text{ MPa}) \times \frac{13.707 \text{ kN/m}}{17.244 \text{ kN/m}} \times \frac{235 \text{ mm}^2}{314 \text{ mm}^2} \times \frac{1}{1} = 0.87(450 \text{ N/mm}^2) \times \frac{13.707 \times 10^6 \text{ N/mm}}{17.244 \times 10^6 \text{ N/mm}} \times \frac{235 \text{ mm}^2}{314 \text{ mm}^2} \times \frac{1}{1} = \mathbf{232.9 \text{ N/mm}^2}$$

Calculate the modification factor:

M_{mid-span} = 26.786 kN.m (From Step 35)

d = 652 mm (From Step 36)

b_{rib,ave} = 258 mm (From Table 19)

$$\text{Modification factor} = 0.55 + \frac{477 - f_s}{120 \left(0.9 + \frac{M_u}{bd^2} \right)} = 0.55 + \frac{477 \text{ N/mm}^2 - 232.9 \text{ N/mm}^2}{120 \left(0.9 \text{ N/mm}^2 + \frac{26.786 \times 10^6 \text{ N.mm}}{258 \text{ mm} \times (652 \text{ mm})^2} \right)} = \mathbf{2.327}$$

The modification factor of 2.327 is larger than 2.0, therefore take the modification factor as 2.0

Allowable span/effective depth ratio = (Modification factor) x (Basic span/effective depth ratio)

Where:

Basic span/effective depth ratio = 24 (From Table 4)

(Modification factor) x (Basic span/effective depth ratio) = 2.0 x 24 = **48**

l_e = 4250 mm (From Step 31, Figure 30)

Actual span ÷ effective depth = 4250 mm ÷ 652 mm = **6.518**

6.518 < 48, therefore the rib is okay.

TROUGH SLAB DESIGN

Step 46: Calculate the actual long-term deflections for the ribs.
Determine the Moment of Inertia for the cross-sectional area of the rib.

This is done by taking the width and the thickness of the rib into consideration using the following formula:

$$I_x = \frac{bh^3}{12}$$

The short-term modulus of elasticity for the specified strength of the concrete can be determined using Table 8.

For long term deflections, a conservative assumption is that the modulus of elasticity is only half the value given in Table 8.

Long term deflections can then be determined using one of the following equations:

$$\text{Truly simply supported beam } \delta = \frac{5wl^4}{384E_c I_x}$$

$$\text{Beam with one end continuous } \delta = 0.0099 \frac{wl^4}{E_c I_x}$$

$$\text{Beam with both ends continuous } \delta = 0.0068 \frac{wl^4}{E_c I_x}$$

Long term deflections can then be determined using the following formula:

The recommended limit to prevent damage to finishes and partitions is the span divided by 250 (Refer to SABS 0100-1 Ed.2.2, clause 4.3.6.2.1).

If the calculated actual long-term deflection is less than the recommended limit, then the beam is okay.

Example:

$b_{\text{rib,ave}} = 258 \text{ mm}$ (From Table 19)

$h = t_{\text{beam}} = 700 \text{ mm}$ (From Step 9)

Rib Serviceability Load $w_{\text{rib}} = 13.707 \text{ kN/m}$ per rib (From Step 45)

$l = l_{\text{ex}} = 4250 \text{ mm}$ (From Step 32)

$$I_x = \frac{bh^3}{12} = \frac{258 \text{ mm} \times (700 \text{ mm})^3}{12} = 7.375 \times 10^9 \text{ mm}^4$$

$f_{\text{cu}} = 30 \text{ MPa}$ (From Step 17)

$E_c = 28 \text{ GPa}$ (From Table 8), therefore $E_c = 28 \text{ GPa} \div 2 = 14 \text{ GPa}$

End span condition = One end continuous

Actual long-term deflection

$$\delta = 0.0099 \frac{wl^4}{E_c I_x} = \frac{0.0099 \times (13.707 \text{ kN/m}) \times (4250 \text{ mm})^4}{(14 \times 10^3 \text{ GPa}) \times (7.375 \times 10^9 \text{ mm}^4)} = \frac{0.0099 \times (13.707 \times 10^3 \text{ kN/mm}) \times (4250 \text{ mm})^4}{(14 \times 10^6 \text{ kN/mm}^2) \times (7.375 \times 10^9 \text{ mm}^4)} = 0.4 \text{ mm}$$

$$\text{Recommended limit} = \frac{\text{Span}}{250} = \frac{4250 \text{ mm}}{250} = 17.0 \text{ mm}$$

$0.4 \text{ mm} < 17.0 \text{ mm}$ therefore the deflection of the rib is okay.

TROUGH SLAB DESIGN

Step 47: Steel detailing of mid-span tension reinforcing steel for the ribs.

The following rules must be taken into consideration when detailing mid-span tension reinforcement:

Rule 1. Span:

- 1.1 The assumption is made that the Span Length 'L' equals the lesser of the clear span plus the effective depth and the distance from centre line to centre line of the supports.

Rule 2. Simply supported beams:

- 2.1 At least 50% of the tension reinforcing steel at mid-span shall extend to the supports and have an effective anchorage of 12 bar diameters beyond the centre line of the support.
- 2.2 No hook or bend shall begin before the centre line.
- 2.3 At least 25% of the reinforcing steel shall extend to within 0.08L of the support centre line and the rest shall extend to within 0.15L of the support centre line.

Rule 3. Cantilever beams:

- 3.1 At least 50% of the tension reinforcing steel shall extend to the end of the cantilever (and be turned down for bond if necessary) and the remaining reinforcing steel shall extend to a distance (from the face of the support) of the greater of 0.5L and 45 bar diameters.

Rule 4. Continuous beams:

- 4.1 At least 30% of the bottom reinforcing steel in tension at mid-span shall extend to the supports.
- 4.2 Half the remainder shall extend to within 0.2L of the centre line of internal supports.
- 4.3 The remaining 35% shall extend to within 0.1L of the centre line of supports.
- 4.4 At a non-continuous end, 50% of the tension reinforcing steel shall extend to the supports and terminate in an effective anchorage as in Rule 2 above and the remainder must extend to within 0.05L of the centre line of the support.

(Refer to SABS 0144 Ed.3, clauses 7.10.4 and 7.10.5).

Only the reinforcement required for the short span needs to be determined.

The same reinforcement configuration can then be applied to the ribs in the long span.

Example:

b = 180 mm (From Table 19)

Tension reinforcement = 1 No. of Y20 reinforcing bar (From Step 38)

The Trough section is non-continuous at Beam A1 and continuous over Beam B1 (From Figure 30)

Supports = 450 mm (Beam A1) and 1050 mm (Beam B1)

Clear span = 3500 mm (From Figure 30)

d = 652 mm (From Step 36)

L = lesser of (3500 mm + 652 mm) = **4152 mm** and (3500 mm + (450 mm + 1050 mm) ÷ 2) = **5000 mm**.

It is recommended that the above rules are used as a guideline only.

The reinforcing configuration, type, size, and amount or reinforcing steel detailed, will vary between designers and detailers.

It is recommended that reinforcing steel is detailed using the minimum amount of bars and lengths of bars.

Using many different bar lengths and configurations will increase the risk of fixing errors and fixing time on site.

It is further recommended that bottom steel is detailed to pass the centre line of the supports by the anchorage length given in Rule 2.1 above.

In this case, Y20 reinforcing bars are used for bottom steel, therefore each reinforcing bar should pass the centre line of the supports by at least 20 mm x 12 times the diameter = **240 mm**.

TROUGH SLAB DESIGN

Figure 32 shows the bottom tension reinforcement for the Trough ribs.

1 No. reinforcing bar with a bend equivalent to 12 x the bar diameter extended past the centre line of the support

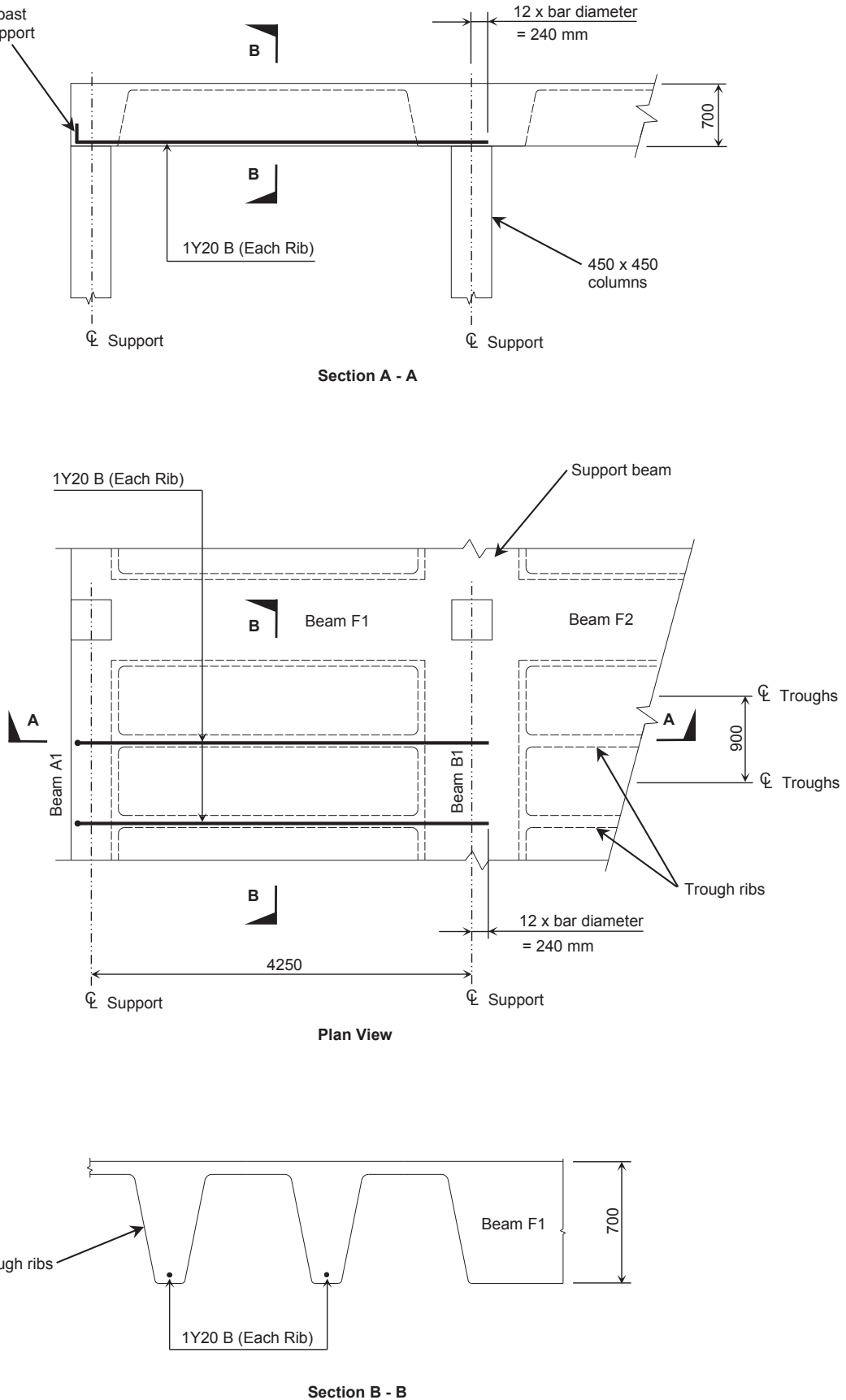

Figure 32 – Bottom Tension Reinforcement For Trough Ribs

COFFER AND TROUGH SLAB DESIGN

TROUGH SLAB DESIGN

Step 48: Steel detailing of the stirrups for the ribs of the Trough slab.

The designer may increase the spacing to achieve a more economical design, provided the spacing is below the maximum spacing of $0.75d$.

Provide R8 stirrups at a 450 mm spacing (From Step 41), along the full length of the Trough rib.

For this example, no additional reinforcement will be provided at the top of each stirrup, other than the layer of mesh Ref 193.

In addition to the bottom tension reinforcement, Figure 33 shows the reinforcing stirrups for the short span ribs.

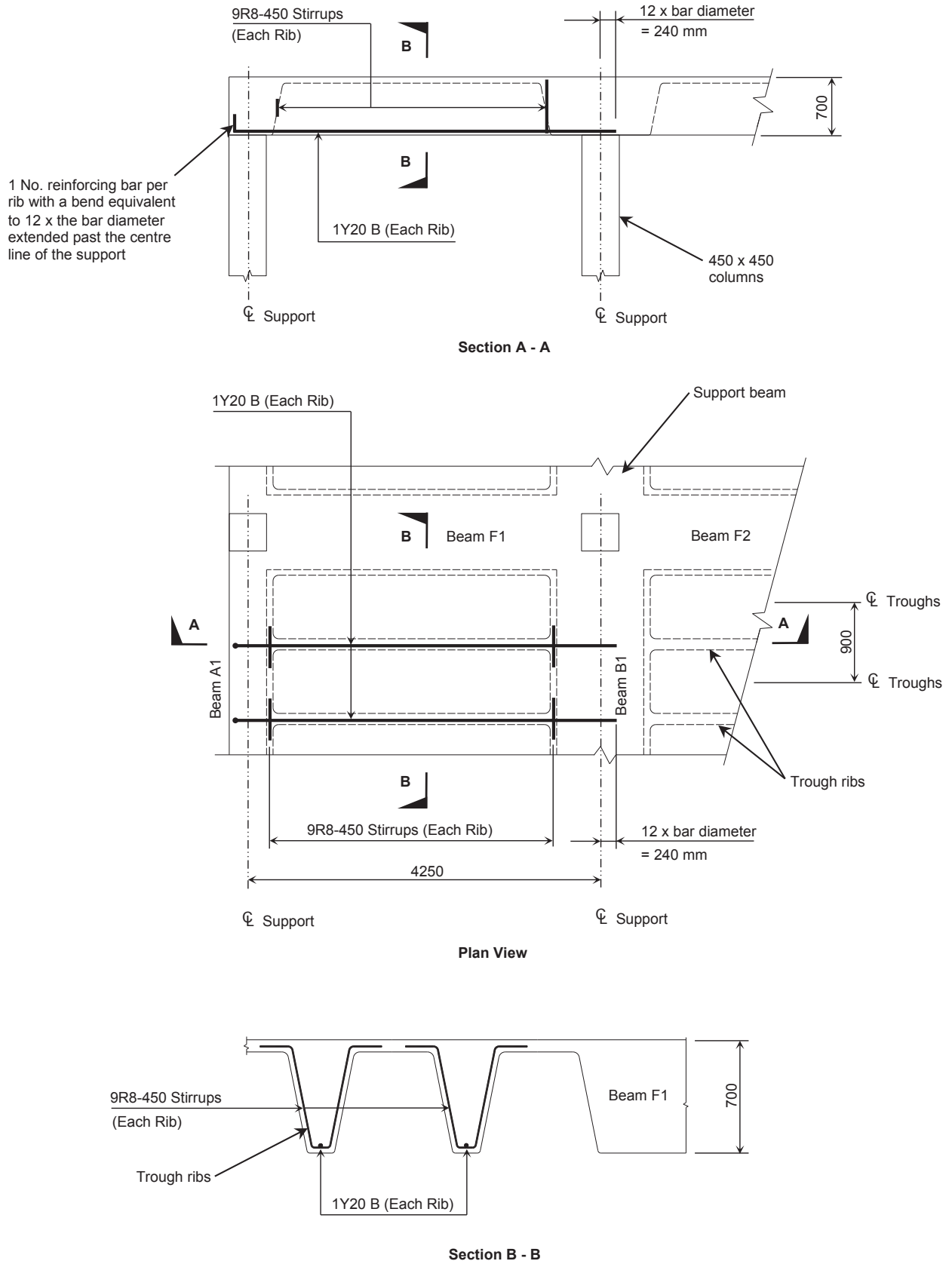

Figure 33 – Bottom Tension Reinforcement And Stirrups For Short Span Ribs

TROUGH SLAB DESIGN

Step 49: Steel detailing of nominal reinforcing steel at mid-span and the supports for the Trough slab.
 Nominal reinforcement = Mesh Ref 193 (From Step 42).

Therefore, install 1 layer of mesh Ref 193 over the complete area of Trough beams and ribs to control cracking and to act as nominal reinforcement within the Trough slab areas.

In addition to the bottom tension reinforcement and stirrups, Figure 34 shows the mesh reinforcement.

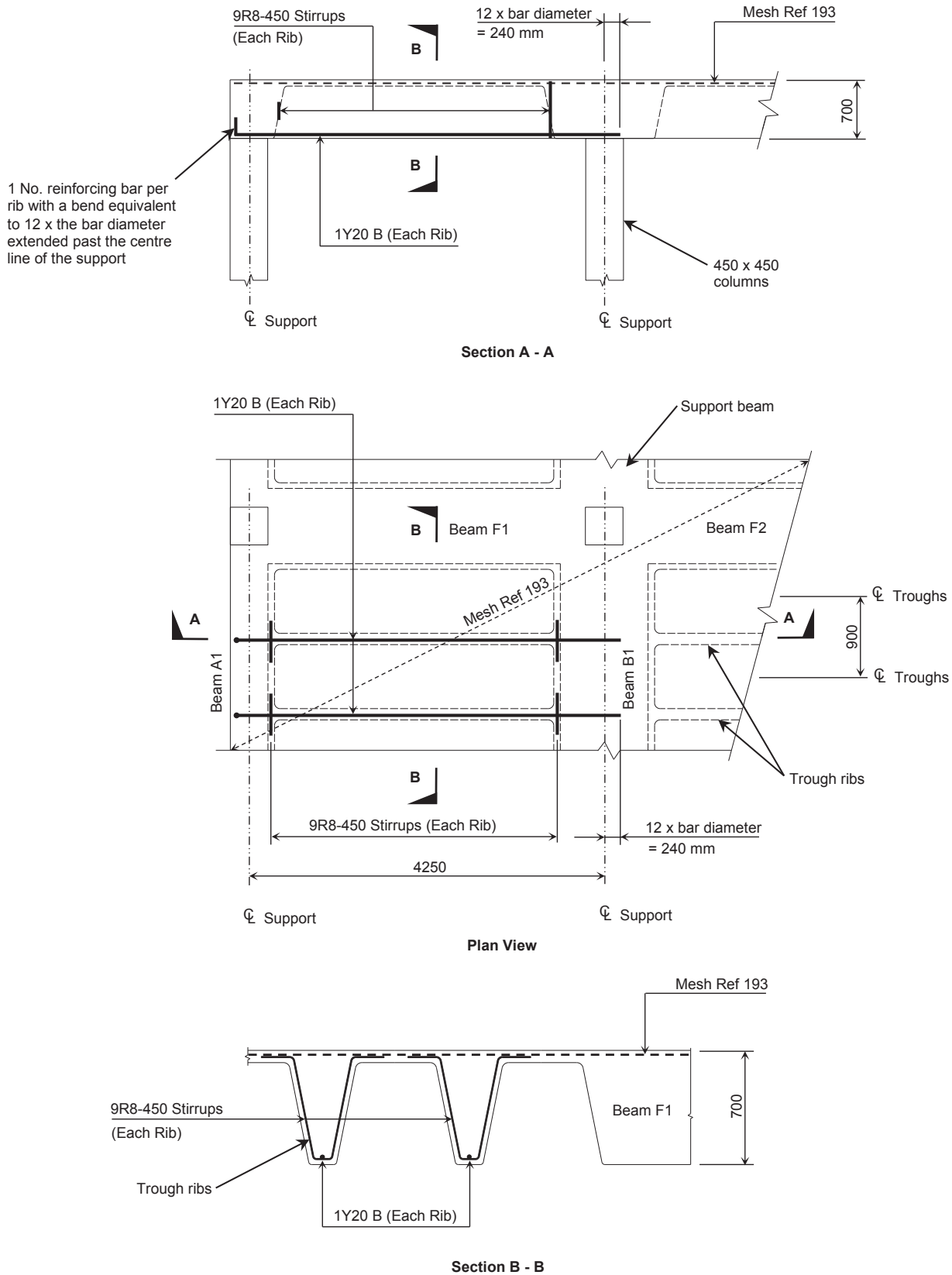

Figure 34 – Bottom Reinforcement, Stirrups And Mesh For Trough Ribs

TROUGH SLAB DESIGN

Step 50: Steel detailing of tension reinforcing steel at the support and the nominal top reinforcing steel at mid-span.

The following rules must be taken into consideration when detailing mid-span tension reinforcement:

Rule 1. Span:

- 1.1 The assumption is made that the Span Length 'L' equals the lesser of the clear span plus the effective depth and the distance from centre line to centre line of the supports.

Rule 2. Simply supported beams:

- 2.1 No tension reinforcing steel in top of beam required at support.

Rule 3. Cantilever beams:

- 3.1 At least 50% of the tension reinforcing steel shall extend to the end of the cantilever (and be turned down for bond if necessary) and the remaining reinforcing steel shall extend to a distance (from the face of the support) of the greater of 0.5L and 45 bar diameters.

Rule 4. Continuous beams:

- 4.1 At least 20% of the top reinforcement in tension over supports of a continuous beam should be made effectively continuous through the spans.
- 4.2 Half the remainder shall extend to within 0.25L from the face of the support.
- 4.3 The remaining reinforcement shall extend to a point at least 0.15L from the face of the support, but no bar should stop at a point less than 45 bar diameters from the face of the support.

(Refer to SABS 0144 Ed.3, clauses 7.10.4 and 7.10.5.3.3).

Example:

$b_{\text{topping}} = 900$ mm (From Step 42)

Tension rebar = 1 No. Y20 reinforcing bar at a spacing of 900 mm (From Step 38)

The Trough section is non-continuous at Beam A1 and continuous over Beam B1 (From Figure 30)

Clear span = 3500 mm (From Figure 30)

Supports = 450 mm (Beam A1) and 1050 mm (Beam B1)

$d = 652$ mm (From Step 36)

$L = \text{lesser of } (3500 \text{ mm} + 652 \text{ mm}) = 4152 \text{ mm} \text{ and } (3500 \text{ mm} + (450 \text{ mm} + 1050 \text{ mm}) \div 2) = 5000 \text{ mm}.$

It is recommended that the above rules are used as a guideline only.

The reinforcing configuration, type, size, and amount or reinforcing steel detailed, will vary between designers and detailers.

It is recommended that reinforcing steel is detailed using the minimum amount of bars and lengths of bars.

Using many different bar lengths and configurations will increase the risk of fixing errors and fixing time on site.

At least 20% of the top tension reinforcing steel should be continuous through the spans.

It is recommended that the remaining 80% of the top reinforcing steel extends to within 0.25L or 45 x bar diameter from the face of the support, whichever is the larger length.

In this case, 1 No. Y20 is used for the top reinforcing steel.

This reinforcing bar should extend past the face of the support by the larger of $(0.25 \times 4152 \text{ mm}) = 1038$ mm and $(45 \times 20 \text{ mm diameter}) = 900$ mm.

Extend the reinforcing bar 1038 mm (Rounded off = 1050 mm) past the face of the support (Refer to Figure 35).

TROUGH SLAB DESIGN

In addition to the bottom tension reinforcement, stirrups and mesh, Figure 35 shows the top tension reinforcement.

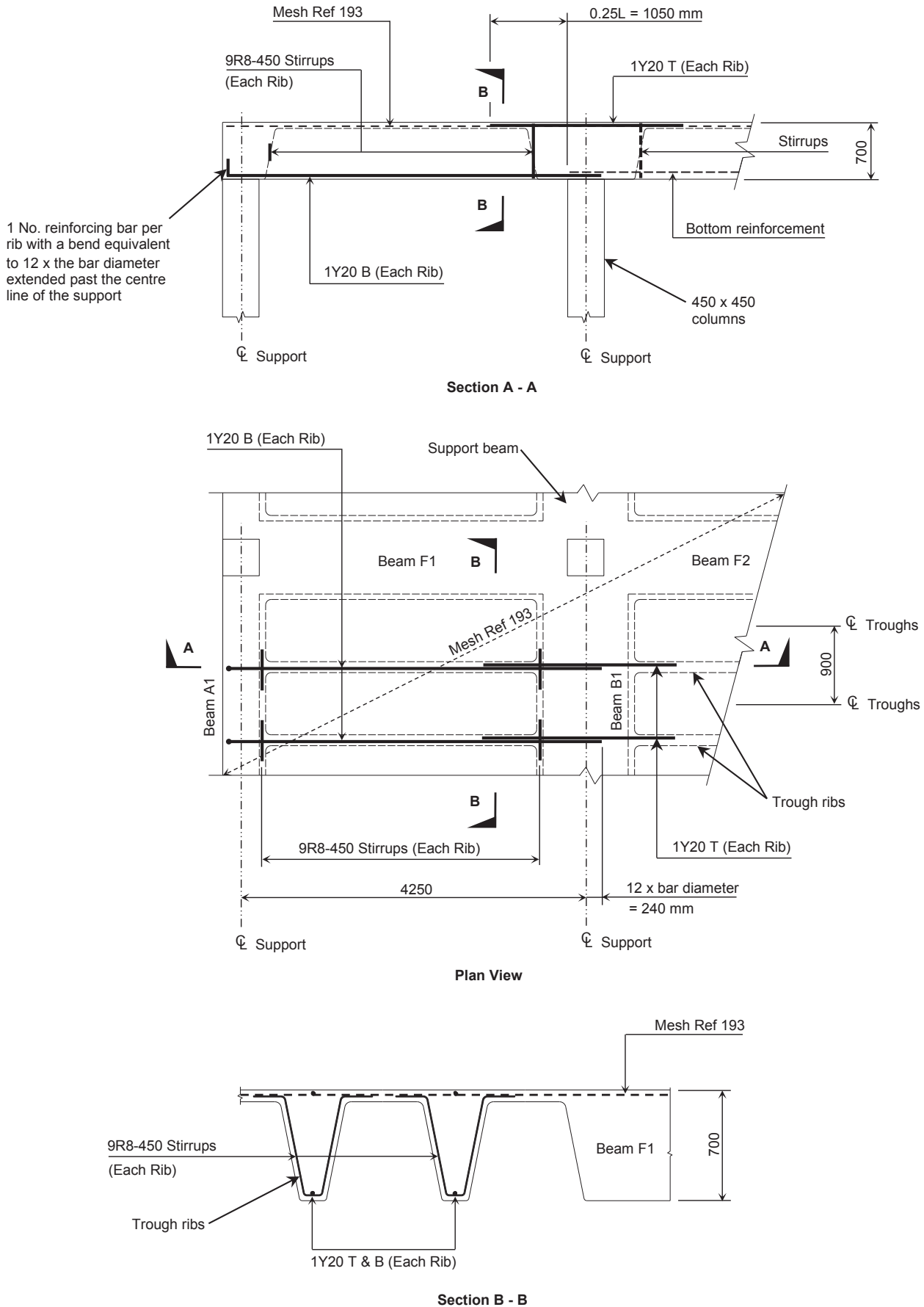

Figure 35 – Top And Bottom Reinforcement, Stirrups And Mesh For Trough Ribs

Work through Steps 1 to 50 until all the Trough beams and ribs are designed.

SUMMARY

Concrete design for Coffers and Trough slabs

Prior to starting a Coffer or Trough slab design, it is recommended that the designer works in conjunction with the architect/structural engineer to establish the required overall parameters of the project (such as the minimum clearance height between floor levels, overall height of the structure, fire resistance requirements, etc.).

In addition, the designer should:

- Refer to the architectural and design considerations shown on Pages 3 and 4 of this Concrete Design Guide.
- Refer to the Form-Scaff Technical User Guide which provides technical information regarding the various formwork components that make up the Coffer and Trough systems.
- Contact Form-Scaff to confirm the availability of the Coffer or Trough equipment and the support work required for the concrete structure.

For the design of a Coffer slab, follow Steps 1 to 50 shown on pages 10 to 54 for worked examples.

For the design of a Trough slab, follow Steps 1 to 50 shown on pages 61 to 103 for worked examples.

Final analysis, reinforced concrete detailing and the checking of drawings and bending schedules for the Coffer and Trough slabs, must be carried out by a suitably qualified professional, competent in reinforced concrete design.

As previously mentioned, this Concrete Design Guide should be used as a guide only.

Note:

This Concrete Design Guide may be also used in conjunction with the 'Coffer and Trough Concrete Design Programme' which is available from Form-Scaff on request.

REFERENCE TABLES	PAGE
Table 1 - Concrete And Mass Reduction Values	04
Table 2 - Step By Step Design Procedure For Coffer Slabs	06
Table 3 - Coffer Dimensions And Approximate Displacement Values	08
Table 4 - Basic Span/Effective Depth Ratios For Rectangular Beams	11
Table 5 - Structural Topping Thickness For Coffers	12
Table 6 - Minimum Percentage Of Reinforcing Steel	19
Table 7 - Cross-Sectional Area Of Reinforcing Bars Per m Width (mm ²)	20
Table 8 - Modulus Of Elasticity Of Concrete	29
Table 9 - Minimum Structural Topping Thickness For Coffers Due To Deflection	36
Table 10 - Bending Moment Coefficients For Rectangular Panels Supported On Four Sides With Provision For Torsional Reinforcement At The Corners	37
Table 11 - Bending Moment Coefficients For Slabs Spanning In Two Directions At Right Angles And Simply Supported On Four Sides	38
Table 12 - Minimum Percentage Of Reinforcement (For Flanged Beam With Web In Tension)	40
Table 13 - Mesh Reinforcement	44
Table 14 - Minimum Percentage Of Reinforcement (For Flanged Beam With Flange In Tension Over Continuous Support)	45
Table 15 - Step By Step Design Procedure For Trough Slabs	56
Table 16 - Trough Middle Sections Dimensions And Approximate Displacement Values	58
Table 17 - Trough End Dimensions And Approximate Displacement Values	59
Table 18 - Preferred Trough Combinations	62
Table 19 - Minimum Structural Topping Thickness For Troughs Due To Deflection	65
Table 20 - Ultimate Bending Moments And Shear Forces In One-way Spanning Slabs	87

ABBREVIATIONS AND SYMBOLS

A_c	Area Of Concrete (mm ²)
Alt	Alternating
A_s	Area Of Tension Reinforcement (mm ²)
$A_{s,max}$	Maximum Area Of Tension Reinforcement (mm ²)
$A_{s,mesh}$	Maximum Area Of Mesh Reinforcement (mm ²)
$A_{s,min}$	Minimum Area Of Tension Reinforcement (mm ²)
$A_{s,prov}$	Area Of Tension Reinforcement Provided (mm ²)
$A_{s,req}$	Area Of Tension Reinforcement Required (mm ²)
$A_{s,req,new}$	New Area Of Tension Reinforcement Required (mm ²)
A_{sv}	Area Of Shear Reinforcement (mm ²)
$A_{sv,prov}$	Area Of Shear Reinforcement Provided (mm ²)
$A_{sv,req}$	Area Of Shear Reinforcement Required (mm ²)
α_{sx}, α_{sy}	Bending Moment Coefficient
β_b	Ratio Of Resistance Moment At mid-span
β_{sx}, β_{sy}	Bending Moment Coefficients
B	Bottom
b	Width, Effective Width (mm)
$b_{rib,ave}$	Average Rib Width (mm)
$b_{rib,bot}$	Rib Width At Bottom (mm)
$b_{rib,top}$	Rib Width At Top (mm)
$b_{topping}$	Width Of Beam Flange (mm)
b_v	Width Of Section (mm)
$b_v h$	Cross-sectional Area (mm ²)
d	Effective Depth (mm)
\bar{C}	Centre Line
δ	Deflection (mm)
diameter _{stirrup}	Diameter Of Stirrup (mm)
DL	Dead load
DL _{beam}	Dead Load On Beam (kN/m ²)
DL _{rib}	Dead Load On Rib (kN/m)
DL _{slab}	Dead Load On Slab (kN/m ²)
E_c	Modulus Of Elasticity Of Concrete (GPa)
EF	Each Face
F	Total Ultimate Load (kN)
f_{cu}	Characteristic Strength Of Concrete (MPa)
f_s	Service Stress In Tension Reinforcement (MPa)
f_y	Characteristic Strength Of Reinforcement (MPa)
f_{yv}	Characteristic Strength Of Link Reinforcement (MPa)
GPa	Gigapascal
>	Greater Than
≥	Greater Than Or Equal To
h	Depth, Thickness (mm)
I_x	Moment Of Inertia (mm ⁴)
K	Deflection Coefficient
kN	Kilonewton
L, l	Length Or Span Length (m), (mm)
LL	Live Load
LL _{beam}	Live Load On Beam (kN/m ²)
LL _{rib}	Live Load On Rib (kN/m)
LL _{slab}	Live Load On Slab (kN/m ²)
L_x, L_y	Length Of Ribs
l_e	Effective Length Of Span (mm)
l_{ex}	Effective Length Of Short Span (mm)
l_x	Length Of Short Side Of Slab (mm)
l_{ey}	Effective Length Of Long Span (mm)
l_y	Length Of Long Side Of Slab (mm)
<	Less Than
≤	Less Than Or Equal To

ABBREVIATIONS AND SYMBOLS

MPa	Megapascal
m	Metre
m ³	Cubic Metres
m ²	Square Metres
mm	Millimeter
Max	Maximum
$M_{mid-span}$	Max. Moment At Mid-Span (kN.m)
M_r	Moment Of Resistance
$M_{sup,outer}$	Max. Moment At Outer Support (kN.m)
$M_{sup,inner}$	Max. Moment At Inner Support (kN.m)
M_{sx}	Max. Moment In x-x Direction (kN.m)
M_{sy}	Max. Moment In y-y Direction (kN.m)
$M_{sx,sup}$	Max. Moment At Support For Short Span (kN.m)
$M_{sx,mid-span}$	Max. Moment At Mid-Span For Short Span (kN.m)
$M_{sy,sup}$	Max. Moment At Support For Long Span (kN.m)
$M_{sy,mid-span}$	Max. Moment At Mid-Span For Long Span (kN.m)
M_u	Ultimate Moment (kN.m)
$M_{u,mid}$	Ultimate Moment At mid-span (kN.m)
$M_{u,sup}$	Ultimate Moment At Support (kN.m)
n	Load On Slab (kN)
No.	Number Of
R	Mild Steel
SLS	Serviceability Limit States
s_v	Stirrup Spacing (mm)
$s_{v,max}$	Maximum Stirrup Spacing (mm)
T	Top
t	Concrete Or Slab Thickness (mm)
t_{beam}	Concrete Beam Thickness (mm)
$t_{topping}$	Structural Topping Thickness (mm)
UDL	Uniformly Distributed Load (kN)
ULS	Ultimate Limit States
V	Design Shear Force (kN)
v	Design Shear Stress (MPa)
$V_{sup,inner}$	Shear Force At Inner Support (kN)
$V_{sup,outer}$	Shear Force At Outer Support (kN)
v_{max}	Maximum Shear Stress (MPa)
v_c	Design Ultimate Shear Stress (MPa)
w	Load (kN)
w_{beam}	Self Weight Of Concrete Beam (kN/m ²)
$W_{rib,ult}$	Ultimate Load Of Rib (kN)
$W_{rib,ser}$	Serviceability Load Of Rib (kN)
w_{slab}	Self Weight Of Concrete Slab (kN/m ²)
w_{total}	Total Ultimate Load (kN/m)
Y	High Yield
γ_m	Partial Safety Factor
γ_1	Self-weight Load Factor for SLS
γ_2	Imposed Load Factor for SLS
γ_3	Self-weight Load Factor for ULS
γ_4	Impose Load Factor for ULS
z	Lever Arm (mm)

Conversions

1 GPa	= 1000 MPa	= 1000000 kPa
1 MPa	= 1000 kN/m ²	= 0.001 kN/mm ²
1 kN	= 100 kg	= 0.1 ton
1000 mm	= 100 cm	= 1 m



coffers and troughs

For Engineering & Design, please contact:

Waco Engineering Services:

📍 181 Barbara Road, Elandsfontein, 1600

☎ +27 11 842 4000

✉ info@wacoengineering.co.za

🌐 www.wacoengineering.co.za

For Product Information & Pricing, please contact:

Form-Scaff:

📍 181 Barbara Road, Elandsfontein, 1600

☎ +27 11 842 4000

✉ formscaff@formscaff.com

🌐 www.formscaff.com